

TOWN OF CHESHIRE, CONNECTICUT

ANNOTATED REQUEST
FOR PROPOSALS

LEGAL NOTICE

TOWN OF CHESHIRE, CONNECTICUT
REQUEST FOR PROPOSALS

RENOVATION TO EXISTING BATHROOM AT QUINNIPIAC PARK
1325 CHESHIRE STREET, CHESHIRE, CT
PROPOSAL #2122-10
MARCH 7, 2022

The Town of Cheshire is seeking competitive proposals for **RENOVATION TO EXISTING BATHROOM AT QUINNIPIAC**, 1325 CHESHIRE STREET, CHESHIRE, CT.

Sealed proposals are due by 11:00 AM on Friday, March 25, 2022 at the office of Cheshire Public Works Room 213, Cheshire Town Hall, 84 South Main Street, Cheshire, Connecticut 06410. At that time, proposals will be opened in public and read aloud.

The documents comprising the Request for Proposals (“RFP Documents”) may be obtained on the Town's website, www.cheshirect.org, under "Businesses" / “Bids and RFs.”

The Town of Cheshire reserves the rights to amend or terminate this Request for Proposals, accept all or any part of a proposal, reject all proposals, waive any informalities or non-material deficiencies in a proposal, and award the proposal to the proposer that, in the Town's sole discretion and judgment, will be in the Town's best interests.

TOWN OF CHESHIRE, CONNECTICUT

**REQUEST FOR PROPOSALS FOR
RENOVATION TO EXISTING BATHROOM AT QUINNIPIAC PARK
1325 CHESHIRE STREET, CHESHIRE, CT**

Proposal Number: PROPOSAL 2122-10

Proposal Opening Date: March 25, 2022

Proposal Opening Time: 11:00 AM

Proposal Opening Place: Cheshire Town Hall, Room (207/209)

The Town of Cheshire is seeking proposals for the RENOVATION TO EXISTING BATHROOM AT QUINNIPIAC PARK, 1325 CHESHIRE STREET, CHESHIRE, CT 06410

One (1) original, four (4) copies and one (1) digital copy on a thumb drive of sealed proposals must be received in the Cheshire Town Hall, Department of Public Works and Engineering, Room 213, 84 South Main Street, Cheshire, CT 06410 by the date and time noted above. The Town of Cheshire (the "Town") will not accept submissions by e-mail or fax. The Town will reject proposals received after the date and time noted above.

The documents comprising this Request for Proposals may be obtained on the Town's website, www.cheshirect.org, under "Proposals & RFP's." **Each proposer is responsible for checking the Town's website to determine if the Town has issued any addenda and, if so, to complete its proposal in accordance with the RFP as modified by the addenda.**

Proposals shall be held firm and cannot be withdrawn for sixty (60) calendar days after the opening date.

The Town reserves the rights to amend or terminate this Request for Proposals, accept all or any part of a proposal, reject all proposals, waive any informalities or non-material deficiencies in a proposal, and award the proposal to the proposer that, in the Town's sole discretion and judgment, will be in the Town's best interests.

This Request for Proposals ("RFP") includes:

- Standard Instructions to Proposers
- Specifications
- Insurance Requirements

- Proposal Form
- Proposer's Legal Status Disclosure
- Proposer's Certification Concerning Equal Employment Opportunities and Affirmative Action Policy
- Proposer's Non Collusion Affidavit
- Proposer's Statement of References
- Addenda, if any
- The Contract in the form attached

TOWN OF CHESHIRE, CONNECTICUT

STANDARD INSTRUCTIONS TO PROPOSERS

1. INTRODUCTION

The Town of Cheshire (the "Town") is soliciting proposals for RENOVATION TO EXISTING BATHROOM AT QUINNIPIAC PARK, 1325 CHESHIRE STREET, CHESHIRE CT 06410. This RFP is not a contract offer, and no contract will exist unless and until a written contract is signed by the Town and the successful proposer.

Interested parties should submit a proposal in accordance with the requirements and directions contained in this RFP. **Proposers are prohibited from contacting any Town employee, officer or official concerning this RFP, except as set forth in Section 6, below. A proposer's failure to comply with this requirement may result in disqualification.**

If there are any conflicts between the provisions or these Standard Instructions to Proposers and any other documents comprising this RFP, these Standard Instructions to Proposers shall prevail.

2. RIGHT TO AMEND OR TERMINATE THE RFP OR CONTRACT

The Town may, before or after proposal opening and in its sole discretion, clarify, modify, amend or terminate this RFP if the Town determines it is in the Town's best interest. Any such action shall be effected by a posting on the Town's website, www.cheshirect.org, under "Businesses" / "Bids & RFPs." Each proposer is responsible for checking the Town's website to determine if the Town has issued any addenda and, if so, to complete its proposal in accordance with the RFP as modified by the addenda.

3. KEY DATES

OPTIONAL Pre-Bid Site Visit:	March 16, 2022 at 10:00 AM
Proposal Opening:	March 25, 2022 at 11:00 AM
Preliminary Notice of Award:	April 13, 2022
Contract Execution:	April 18, 2022
Mobilization for construction:	July 01, 2022
Substantial Completion:	September 02, 2022

Contract Execution:

The Preliminary Notice of Award and Contract Execution dates are anticipated, not certain, dates. If awarded a contract, the successful respondent agrees, by the submission of its proposal, that it shall sign the contract provided by the Town without alteration or modification within five (5) days of receipt of notice of award.

4. OBTAINING THE RFP

All documents that are a part of this RFP may be obtained on the Town's website, www.cheshirect.org, under "Businesses" / "Bids and RFPs."

5. PROPOSAL SUBMISSION INSTRUCTIONS

Proposals must be received in the Cheshire Town Hall, Department of Public Works and Engineering, Room 213, 84 South Main Street, Cheshire, CT 06410] prior to the date and time the proposals are scheduled to be opened publicly. Postmarks prior to the opening date and time do **NOT** satisfy this condition. The Town will not accept submissions by e-mail or fax. Proposers are solely responsible for ensuring timely delivery. The Town will **NOT** accept late proposals.

One (1) original, four (4) copies and one (1) digital copy on a thumb drive of all proposal documents must be submitted in sealed, opaque envelopes clearly labeled with the proposer's name, the proposer's address, the words "**PROPOSAL DOCUMENTS,**" and the **Proposal Title, Proposal Number and Proposal Opening Date.** The Town may decline to accept proposals submitted in unmarked envelopes that the Town opens in its normal course of business. The Town may, but shall not be required to, return such proposal documents and inform the proposer that the proposal documents may be resubmitted in a sealed envelope properly marked as described above.

Proposal prices must be submitted on the Proposal Form included in this RFP. All blank spaces for proposal prices must be completed in ink or be typewritten; proposal prices must be stated in both words and figures. The person signing the Proposal Form must initial any errors, alterations or corrections on that form. Ditto marks (" ") or words such as "SAME" shall not be used in the Proposal Form.

Proposals may be withdrawn personally or in writing provided that the Town receives the withdrawal prior to the time and date the proposals are scheduled to be opened. Proposals are considered valid, and may not be withdrawn, cancelled, or modified, for sixty (60) days after the opening date, to give the Town sufficient time to review the proposals, investigate the proposers' qualifications, secure any required municipal approvals, and execute a binding contract with the successful proposer.

An authorized person representing the legal entity of the proposer must sign the Proposal Form and all other forms included in this RFP.

6. QUESTIONS AND AMENDMENTS

Respondents shall promptly notify the Town of any ambiguity, inconsistency or error which they may discover upon examination of the RFP and/or any documents provided or issued by the Town in conjunction with the RFP. Interpretations, corrections and changes made to the RFP Documents will be made by written addenda. Addenda are written instruments issued by the Town prior to the proposal opening date, which modify or interpret the RFP Documents by addition, deletion, clarification or correction.

Questions concerning the process and procedures applicable to this RFP are to be submitted **in writing** (including by e-mail or fax) and directed **only to**:

Name: Louis Zullo
Department: Human Resources
E-Mail: Lzullo@cheshirect.org
Fax: 2 203-271-6639

Questions concerning the RFP Documents are to be submitted **in writing** (including by e-mail or fax) and directed **only to**:

Name: Daniel Bombero
Department: Public Works
E-mail: DBombero@Cheshirect.org
Fax: 203-271-6659

Proposers are prohibited from contacting any other Town employee, officer or official concerning this RFP. A proposer's failure to comply with this requirement may result in disqualification.

The appropriate Town representative listed above must receive any questions from proposers no later than seven (7) business days before the proposal opening date. That representative will confirm receipt of a proposer's questions by e-mail. The Town will answer all written questions by issuing one or more addenda, which shall be a part of this RFP and the resulting Contract, containing all questions received as provided for above and responses to same.

At least four (4) calendar days prior to proposal opening, the Town will post any addenda on the Town's website, www.cheshirect.org, under "Proposals & RFP's." **Each proposer is responsible for checking the website to determine if the Town has issued any addenda and, if so, to complete its proposal in accordance with the RFP as modified by the addenda.**

No oral statement of the Town, including oral statements by the Town representatives listed above, shall be effective to waive, change or otherwise modify any of the provisions of this RFP, and no proposer shall rely on any alleged oral statement.

7.0 ADDITIONAL INFORMATION/REQUIREMENTS

- 7.1 Delivery/Time for Performance.** TIME IS OF THE ESSENCE with regard to the performance of the services procured through this RFP and the Contract to be entered into by the Town with the selected proposer, if any. Strict compliance with and adherence to the schedule for the services and the Contract is mandatory. If, in the sole opinion of the Town, the selected proposer is not adhering to the contract schedule, upon forty-eight (48) hours written notice from the Town to the selected proposer, the Town shall have the right to direct the proposer to increase its manpower to meet the established project schedule (including any milestones) without additional compensation. Any and all such additional labor or supervision shall be at proposer's sole cost and expense and may include, but shall not be limited to, the Town directing the selected proposer to work overtime, work weekends, or any combination thereof, without any additional compensation being due to proposer for such additional

personnel. In addition, the Town shall have the right but not the obligation to supplement the proposer's forces with that of another vendor in order to achieve compliance with the project schedule. All costs attributable to the supplemental labor and supervision of same shall be the sole obligation and responsibility of the selected proposer. Failure to strictly adhere to the schedule (including any milestones) and the provisions of this paragraph 7.1 shall constitute a material default of proposer's contractual obligations and entitle the Town, in its discretion, to all remedies for default set forth in the contract.

- 7.2 **Termination of Contract.** Contracts shall remain in force for the period within which the selected proposer must perform as set forth in the proposal, unless an extension has been agreed upon as evidenced by a contract extension executed in writing by both the selected proposer and the Town.
- 7.3 **Assignment.** Proposer shall not assign, transfer or subcontract this contract or its obligations hereunder without the prior written consent of the Town, which consent may be withheld in the Town's sole discretion.
- 7.4 **Default.** The contract may be terminated by the Town by written notice of default to the upon non-performance or breach of the contract terms. The awarded proposer shall be obligated to pay the Town for all losses, damages, costs and expenses, including the cost of re-procurement, and attorney's fees incurred defending claims arising from such default and in seeking recovery of all such costs and expenses from proposer and/or its surety. Upon a termination for cause, the Town shall have no further obligation to issue payments to the proposer until resolution of the dispute.
- 7.5 **Conflict.** To the extent any of the contract terms set forth herein conflict with the terms of the form Contract entered into by the parties, the Contract terms shall control.
- 7.6 **COVID-19:** Proposers shall anticipate and incorporate into their proposals all potential costs and delays related to a public health emergency such as the COVID-19 coronavirus pandemic, including the cost of compliance with rules, regulations, guidelines and recommendations issued by public authorities. Potential costs may include but are not limited to, costs related to inefficiency, lost productivity, delays of performance, social distancing, manpower levels, project scheduling, coordination, material/product supply chain delays and disruptions, delivery delays, material escalation, and any other potential costs. In no event shall the Town be liable for any such costs and/or delays.
- The Town reserves the right, either before or after the opening of proposals, to ask any proposer to clarify its proposal or to submit any additional information that the Town in its sole discretion deems desirable.

8. COSTS FOR PREPARING PROPOSAL

Each proposer's costs incurred in developing its proposal are its sole responsibility, and the Town shall have no liability for such costs.

9. OWNERSHIP OF PROPOSALS

All proposals submitted become the Town's property and will not be returned to proposers.

10. FREEDOM OF INFORMATION ACT

All information submitted in a proposal or in response to a request for additional information is subject to disclosure under the Connecticut Freedom of Information Act as amended and judicially interpreted. A proposer's responses may contain financial, trade secret or other data that it claims should not be public (the "Confidential Information"). A proposer must identify specifically the pages and portions of its proposal or additional information that contain the claimed Confidential Information by visibly marking all such pages and portions. Provided that the proposer cooperates with the Town as described in this section, the Town shall, to the extent permitted by law, protect from unauthorized disclosure such Confidential Information.

If the Town receives a request for a proposer's Confidential Information, it will promptly notify the proposer in writing of such request and provide the proposer with a copy of any written disclosure request. The proposer may provide written consent to the disclosure, or may object to the disclosure by notifying the Town in writing to withhold disclosure of the information, identifying in the notice the basis for its objection, including the statutory exemption(s) from disclosure. The proposer shall be responsible for defending any complaint brought in connection with the nondisclosure, including but not only appearing before the Freedom of Information Commission, and providing witnesses and documents as appropriate.

11. REQUIRED DISCLOSURES

In its Proposal Form each proposer must disclose, if applicable:

- Its inability or unwillingness to meet any requirement of this RFP, including but not only any of the Contract Terms referenced herein and in the contract template provided by the Town as part of this RFP (if applicable);
- If it is listed on the State of Connecticut's Debarment List;
- If it is ineligible, pursuant to Conn. Gen. Stat. § 31-57b, to be awarded the Contract because of occupational safety and health law violations;
- All resolved and pending arbitrations and litigation matters in which the proposer or any of its principals (regardless of place of employment) has been involved within the last ten (10) years;
- All criminal proceedings in which the proposer or any of its principals (regardless of place of employment) has ever been the subject; and
- Each instance in which it or any of its principals (regardless of place of employment) has ever been found to have violated any state or local ethics law, regulation, ordinance, code, policy or standard, or to have committed any other offense arising out of the submission of proposals or bids or the performance of work on public works projects or contracts.

A proposer's acceptability based on these disclosures lies solely in the Town's discretion.

12. REFERENCES

Each proposer must complete and submit the Proposer's Statement of References form included in this RFP.

13. LEGAL STATUS

If a proposer is a corporation, limited liability company, or other business entity that is required to register with the Connecticut Secretary of the State's Office, it must have a current registration on file with that office. The Town may, in its sole discretion, request acceptable evidence of any proposer's legal status.

14. PROPOSAL (BID) SECURITY

Each proposal must be accompanied by a proposal (bid) bond with a surety acceptable to the Town in an amount equal to at least **TEN PERCENT (10%)** of the proposal amount. The proposal (bid) bond shall be written by a company or companies licensed to issue bonds in the State of Connecticut, which company or companies shall have at least an "A-" VIII policyholders rating as reported in the latest edition of Best Publication's Key Rating Guide. The successful proposer, upon its refusal or failure to execute and deliver the Contract, certificate(s) of insurance, W-9 form, performance security or other documents required by this RFP within **five (5) business days** of written notification of preliminary award, unless the Town otherwise agrees in writing, shall forfeit to the Town, as liquidated damages for such failure or refusal, the security submitted with its proposal.

Upon the successful proposer's execution of the Contract in the form provided with this RFP, the Town shall return the proposal security to the successful proposer and to all other proposers.

15. PRESUMPTION OF PROPOSER'S FULL KNOWLEDGE

Each proposer is responsible for having read and understood each document in this RFP and any addenda issued by the Town. A proposer's failure to have reviewed all information that is part of or applicable to this RFP, including but not limited to any addenda posted on the Town's website, shall in no way relieve it from any aspect of its proposal or the obligations related thereto.

Each proposer is deemed to be familiar with and is required to comply with all federal, state and local laws, regulations, ordinances, codes and orders that in any manner relate to this RFP or the performance of the work described herein.

By submitting a proposal, each proposer represents that it has thoroughly examined and become familiar with the scope of work outlined in this RFP, and it is capable of performing the work to achieve the Town's objectives. If applicable, each proposer shall visit the site, examine the areas and thoroughly familiarize itself with all conditions of the property before preparing its proposal.

16. SUBSTITUTION FOR NAME BRANDS

The proposer must attach detailed information concerning deviations from any name brands specified in the RFP and explain in detail how the substitution compares with the name brand's specifications. The Town in its sole discretion shall decide whether the substitution is acceptable.

17. TAX EXEMPTIONS

The Town is exempt from the payment of federal excise taxes and Connecticut sales and use taxes. Federal Tax Exempt #066-001971. Exemption from State sales tax per Conn. Gen. Stat. Chapter 219, § 12-412(1). No exemption certificates are required, and none will be issued.

18. INSURANCE

The successful proposer shall, at its own expense and cost, obtain and keep in force at least the insurance listed in the Insurance Requirements that are a part of this RFP. The Town reserves the right to require from the successful proposer a complete, certified copy of any required insurance policy.

19. PERFORMANCE SECURITY

The successful proposer shall furnish security performance bond. The Performance Security shall be the full amount of the Contract price. The Performance Security shall be issued by a company licensed by the State of Connecticut that is a T List surety and has at least an "A-" VIII policyholders rating according to Best Publication's latest edition Key Rating Guide." The cost of the Performance Security shall be included in the proposal price.

In addition to the Performance Security, the successful proposer shall furnish a bond covering the successful proposer's payment to its subcontractors and suppliers of all obligations arising under the Contract (the "Payment Bond"). The Payment Bond shall be (a) in the full amount of the Contract price; (b) in a form reasonably acceptable to the Town; and (c) issued by a company licensed by the State of Connecticut that has at least an "A-" VIII policyholders rating according to Best Publication's latest edition Key Rating Guide and is on the T List. The cost of the Payment Bond shall be included in the proposal price.

20. DELIVERY ARRANGEMENTS

"THIS ITEM IS NOT APPLICABLE TO THIS RFP"

21. AWARD CRITERIA; SELECTION; CONTRACT EXECUTION

All proposals will be publicly opened and read aloud as received on the date, at the time, and at the place identified in this RFP. Proposers may be present at the opening, unless expressly prohibited by the Town.

The Town reserves the right to correct, after proposer verification, any mistake in a proposal that is a clerical error, such as a price extension, decimal point error or FOB terms. If an error exists in an extension of prices, the unit price shall prevail. In the event of a discrepancy between the price quoted in words and in figures, the words shall control.

The Town reserves the rights to accept all or any part of a proposal, reject all proposals, and waive any informalities or non-material deficiencies in a proposal. The Town also reserves the right, if applicable, to award the purchase of individual items under this RFP to any combination of separate proposals or proposers.

The Town will accept the proposal that, all things considered, the Town determines is in its best interests. Although price will be an important factor in most RFPs, it will not be the only basis for award. Due consideration may also be given to a proposer's experience, references, service, ability to respond promptly to requests, past performance, and other criteria relevant to the Town's interests, including compliance with the procedural requirements stated in this RFP.

The Town will not award the proposal to any business that or person who is in arrears or in default to the Town with regard to any tax, debt, charge, contract, security or any other obligation.

If the lowest proposer meets all specifications, is responsive, and, if applicable, qualified, but the proposal is not acceptable to the Town Manager or, if applicable, the Public Building Commission or the Board of Education, the matter must be referred to the Town Council for its decision on whether to reject all proposals, to accept a higher proposal, or to take such other action as may be in the Town's best interests.

The Town will select the proposal that it deems to be in the Town's best interest and issue a Preliminary Notice of Award to the successful proposer. The award may be subject to further discussions with the proposer. **The making of a preliminary award to a proposer does not provide the proposer with any rights and does not impose upon the Town any obligations. The Town is free to withdraw a preliminary award at any time and for any reason. A proposer has rights, and the Town has obligations, only if and when a Contract is fully executed by the Town and the proposer.**

If the proposer does not execute the Contract within five (5) business days of the date of the Preliminary Notice of Award, unless extended by the Town, the Town may call any proposal security provided by the proposer and may enter into discussions with another proposer.

The Preliminary Notice of Award and Contract Execution dates in Section 3's Key Dates are anticipated, not certain, dates.

22. AFFIRMATIVE ACTION, AND EQUAL OPPORTUNITY

Each proposer must submit a completed Proposer's Certification Concerning Equal Employment Opportunities and Affirmative Action Policy form included with this RFP. Proposers with fewer than ten (10) employees should indicate that fact on the form and return the form with their proposals.

23. NONRESIDENT CONTRACTORS

If the successful proposer is a "nonresident contractor" as defined in Conn. Gen. Stat. § 12-430(7)(A) as amended, it shall comply fully with the provisions of § 12-430(7) and, prior to execution of the Contract, shall furnish the Town with a copy of the requisite certificate of compliance set forth in C.G.S. § 12-430(7)(E). The successful proposer agrees to defend, indemnify, and hold harmless the Town, its employees, officers, officials, agents, volunteers and independent contractors, including any of the foregoing sued as individuals (collectively, the "Town Indemnified Parties"), from any and all taxes, interest and penalties that the State of Connecticut asserts are due with respect to the successful proposer's activities under the Contract.

The successful proposer shall also be required to pay any and all attorney's fees incurred by the Town Indemnified Parties in enforcing any of the successful proposer's obligations under this section, whether or not a lawsuit or other proceeding is commenced, which obligations shall survive the termination or expiration of the Contract.

24. COMPLIANCE WITH IMMIGRATION LAWS

By submitting a proposal, each proposer confirms that it has complied, and during the term of the Contract will comply, with the Immigration Reform and Control Act ("IRCA") and that each person it provides under the Contract will at all times be authorized for employment in the United States of America. Each proposer confirms that it has a properly completed Employment

Eligibility Verification, Form I-9, for each person who will be assigned under the Contract and that it will require each subcontractor, if any, to confirm that it has a properly completed Form I-9 for each person who will be assigned under the Contract.

The successful proposer shall defend, indemnify, and hold harmless the Town, its employees, officers, officials, agents, volunteers and independent contractors, including any of the foregoing sued as individuals (collectively, the "Town Indemnified Parties"), against any and all proceedings, suits, actions, claims, damages, injuries, awards, judgments, losses or expenses, including fines, penalties, punitive damages, attorney's fees and costs, brought or assessed against, or incurred by, the Town Indemnified Parties related to or arising from the obligations under IRCA imposed upon the successful proposer or its subcontractor. The successful proposer shall also be required to pay any and all attorney's fees and costs incurred by the Town Indemnified Parties in enforcing any of the successful proposer's obligations under this provision, whether or not a lawsuit or other proceeding is commenced, which obligations shall survive the termination or expiration of the Contract.

25. NON COLLUSION AFFIDAVIT

Each proposer shall submit a completed Proposer's Non Collusion Affidavit that is part of this RFP.

26. CONTRACT TERMS

The following provisions will be among the mandatory terms of the Town's Contract with the successful proposer. If a proposer is unwilling or unable to meet any of these Contract Terms, the proposer must disclose that inability or unwillingness in its Proposal Form (see Section 11 of these Standard Instructions to Proposers):

a. DEFENSE HOLD HARMLESS AND INDEMNIFICATION

The successful proposer agrees, to the fullest extent permitted by law, to defend, indemnify, and hold harmless the Town, its employees, officers, officials, agents, volunteers, boards, commissions, committees, and independent contractors, including any of the foregoing sued as individuals (collectively, the "Town Indemnified Parties"), from and against all proceedings, suits, actions, claims, damages, injuries, awards, judgments, losses or expenses, including attorney's fees, arising out of or relating, directly or indirectly, to the successful proposer's performance of the contract, including but not limited to proposer's malfeasance, misconduct, negligence or failure to meet its obligations under the RFP or the Contract. The successful proposer's obligations under this section shall not be limited in any way by any limitation on the amount or type of the successful proposer's insurance. Nothing in this section shall obligate the successful proposer to indemnify the Town

Indemnified Parties against liability for damage arising out of bodily injury to persons or damage to property caused by or resulting from the negligence of the Town Indemnified Parties.

In any and all claims against the Town Indemnified Parties made or brought by any employee of the successful proposer, or anyone directly or indirectly employed or contracted with by the successful proposer, or anyone for whose acts or omissions the successful proposer is or may be liable, the successful proposer's obligations under this section shall not be limited by any limitation on the amount or type of damages, compensation or benefits payable by the successful proposer under workers' compensation acts, disability benefit acts, or other employee benefits acts.

The successful proposer shall also be required to pay any and all attorney's fees incurred by the Town Indemnified Parties in enforcing any of the successful proposer's obligations under this section, which obligations shall survive the termination or expiration of this RFP and the Contract.

As a municipal agency of the State of Connecticut, the Town will NOT defend, indemnify, or hold harmless the successful proposer.

b. ADVERTISING

The successful proposer shall not name the Town in any advertising, news releases, or promotional efforts without the Town's prior written approval.

If it chooses, the successful proposer may list the Town in a Statement of References or similar document required as part of its response to a public procurement. The Town's permission to the successful proposer to do so is not a statement about the quality of the successful proposer's work or the Town's endorsement of the successful proposer:

c. W-9 FORM

The successful proposer must provide the Town with a completed W-9 form before Contract execution.

d. PAYMENTS

Proposers are encouraged to offer discounts for early payment. All other payments are to be made 30 days after the appropriate Town employee receives and approves the invoice, unless otherwise specified in the Specifications or Contract.

"In each of its contracts with subcontractors or materials suppliers, the successful proposer shall agree to pay any amounts due for labor performed or materials furnished not later than thirty (30) days after the date the successful proposer receives payment from the Town that encompasses the labor performed or materials furnished by such subcontractor or material supplier. The successful proposer shall also require in each of its contracts with subcontractors that such subcontractor shall, within thirty (30) days of receipt of payment from the successful proposer, pay any amounts due any sub-subcontractor or material supplier, whether for labor performed or materials furnished.

Each payment application or invoice shall be accompanied by a statement showing the status of all pending change orders, pending change directives and approved changes to the Contract. Such statement shall identify the pending change orders and pending change directives, and shall include the date such change orders and change directives were initiated, additional cost and/or time associated with their performance and a description of any work completed. The successful proposer shall require each of its subcontractors and suppliers to include a similar statement with each of their payment applications or invoices."

e. TOWN INSPECTION OF WORK

The Town may inspect the successful proposer's work at all reasonable times. This right of inspection is solely for the Town's benefit and does not transfer to the Town the responsibility for discovering patent or latent defects. The successful proposer has the sole and exclusive responsibility for performing in accordance with the Contract.

f. REJECTED WORK OR MATERIALS

The successful proposer, at its sole cost and expense, shall remove from the Town's property rejected items, commodities and/or work within 48 hours of the Town's notice of rejection. Immediate removal may be required when safety or health issues are present.

g. MAINTENANCE AND AVAILABILITY OF RECORDS

The successful proposer shall maintain all records related to the work described in the RFP for a period of five (5) years after final payment under the Contract or until all pending Town, state and federal audits are completed, whichever is later. Such records shall be available for examination and audit by Town, state and federal representatives during that time, at no cost to the Town.

h. SUBCONTRACTING

Prior to entering into any subcontract agreement(s) for the work described in the Contract, the successful proposer shall provide the Town with written notice of the identity (full legal name street address, mailing address (if different from street address), and telephone number) of each proposed subcontractor. The Town shall have the right to object to any proposed subcontractor by providing the successful proposer with written notice thereof within seven (7) business days of receipt of all required information about the proposed subcontractor. If the Town objects to a proposed subcontractor, the successful proposer shall not use that subcontractor for any portion of the work described in the Contract.

All permitted subcontracting shall be subject to the same terms and conditions as are applicable to the successful proposer. The successful proposer shall remain fully and solely liable and responsible to the Town for performance of the work described in the Contract. The successful proposer also agrees to promptly pay each of its subcontractors within thirty (30) days of receipt of payment from the Town or otherwise in accordance with law. The successful proposer shall assure compliance with all requirements of the Contract. The successful proposer shall also be fully and solely responsible to the Town for the acts and omissions of its subcontractors and of persons employed, whether directly or indirectly, by its subcontractor(s).

i. PREVAILING WAGES

State law may require that wages paid on an hourly basis to any person performing the work of any mechanic, laborer or worker under the Contract and the amount of payment or contribution paid or payable on behalf of each such person to any employee welfare fund, as defined in Conn. Gen. Stat. § 31-53, as amended, shall be at a rate equal to the rate customary or prevailing for the same work in the same trade or occupation in the Town. A successful proposer who is not obligated by agreement to make payment or contribution on behalf of such persons to any such employee welfare fund shall pay to each mechanic, laborer or worker as part of such person's wages the amount of payment or contribution for such person's classification on each pay day. Upon Contract award, the successful proposer must certify under oath to the State Labor Commissioner the pay scale to be used by the successful proposer and its subcontractors.

j. PREFERENCES

"THIS ITEM IS NOT APPLICABLE TO THIS RFP"

[The following requirements were added by P.A. 15-5, applicable to municipal public works projects over \$50,000 funded in whole or in part by state funds.]

As required by statute, regulation or other applicable law, Respondent and any Subcontractor shall monitor and track MBE and WBE, local workforce and overall labor participation, including Set Aside documentation. If this Project is funded in whole or in part by funds from the State of Connecticut, Public Act 15-5 (§§58-71 and 88) requires that, effective with all contracts executed after October 1, 2015, all solicitations for municipal public works contracts funded in whole or in part with State funds state in the notice of solicitation that the contract must comply with the set asides mandated by Public Act 15-5. The set aside requirements include a requirement that 25% of the total value of contracts in excess of \$50,000.00 be set aside for exclusive bidding for "small contractors," as defined by Section 58 (a) (1), and 25% of such amount (that is, 6.25% of the total value), be set aside for "minority business enterprises," as defined by Section 58(a) (4). For contracts in excess of \$50,000.00, Respondent must have obtained Commission approval of their Affirmative Action Plan prior to contract execution. Respondent is expressly directed to review Public act 15-5, sections 58-71 and 88, to familiarize itself with the requirements of such laws. The Town also directs Respondent's attention to sections 63 and 64 (non-discrimination requirements) and 66-68 (affirmative action requirements).

The Respondent agrees and warrants that in the performance of the Contract such Respondent will not discriminate or permit discrimination against any person or group of persons on the grounds of race, color, religious creed, age, marital status, national origin, ancestry, sex, gender identity or expression, sexual orientation, intellectual disability, mental disability or physical disability, including, but not limited to, blindness, unless it is shown by such Respondent that such disability prevents performance of the work involved, in any manner prohibited by the laws of the United States or of the state of Connecticut. The Respondent further agrees to take affirmative action to insure that applicants with job-related qualifications are employed and that employees are

treated when employed without regard to of race, color, religious creed, age, marital status, national origin, ancestry, sex, gender identity or expression, intellectual disability, mental disability or physical disability, including, but not limited to, blindness, unless it is shown by such Respondent that such disability prevents performance of the work involved; (2) the Respondent agrees, in all solicitations or advertisements for employees placed by or on behalf of the Respondent, to state that it is an ."affirmative action-equal opportunity employer" in accordance with regulations adopted by the commission; (3) the Respondent agrees to provide each labor union or representative of workers with which such Respondent has a collective bargaining agreement or other contract or understanding and each vendor with which such Respondent has a contract or understanding, a notice to be provided by the commission advising the labor union or workers' representative of the Respondent's commitments under this section, and to post copies of the notice in conspicuous places available to employees and applicants for employment; (4) the Respondent agrees to comply with each provision of this section and sections 46a-68e and 46a-68f and with each regulation or relevant order issued by said commission pursuant to sections 46a-56, 46a-68e,46a-68f and 46a-86; (5) the Respondent agrees to provide the Commission on Human Rights and Opportunities with such information requested by the commission, and permit access to pertinent books, records and accounts, concerning the employment practices and procedures of the Respondent as relate to the provisions of this section and section 46a-56.

Any Respondent who is a party to a municipal public works contract or quasi-public agency project, where any such contract is valued at less than \$50,000 for each year of the contract, shall provide the Commission on Human Rights and Opportunities with a written or electronic representation that complies with the nondiscrimination agreement and warranty under subsection (A)(1) above, provided if there is any change in such representation, the Respondent shall provide the updated representation to the Commission not later than 30 days after such change. Any Respondent who is a party to a municipal public works contract or a quasi-public agency project, where any such contract is valued at \$50,000 or more for any year of the contract, shall provide the Commission with any one of the following: (1) Documentation in the form of a company or corporate policy adopted by resolution of the board of directors, shareholder, managers, members or other governing body of such Respondent that complies with the nondiscrimination agreement and warranty under subsection (A)(1) of this section; (2) Documentation in the form of a company or corporate policy adopted by a prior resolution of the board of directors, shareholders, managers, members or other governing body of such Respondent if (a) the prior resolution is certified by a duly authorized corporate officer of such contractor to be in effect on the date the documentation is submitted, and the executive director of the Commission on Human Rights and Opportunities or designee certifies that the prior resolution complies with the nondiscrimination agreement and warranty under subdivision (A)(1) of this section; or (3) Documentation in the form of an affidavit signed under penalty of false statement by a chief executive officer, president, chairperson or other corporate officer duly authorized to adopt company or corporate policy that certifies that the company or corporate policy of the contractor complies with the nondiscrimination agreement and warranty under subdivision (A)(1) of this section and is in effect on the date the affidavit is signed..

"Minority business enterprise" means any small contractor or supplier of materials fifty-one per cent or more of the capital stock, if any, or assets of which is owned by a person or persons: (1) Who are active in the daily affairs of the enterprise, (2) who have the power to direct the management and policies of the enterprise and (3) who are members of a minority, as such term is defined in subsection (a) of section 32-9n; and "good faith" means that degree of diligence which a reasonable person would exercise in the performance of legal duties and obligations. "Good faith efforts" shall include, but not be limited to, those reasonable initial efforts necessary to comply with statutory or regulatory requirements and additional or substituted efforts when it is determined that such initial efforts will not be sufficient to comply with such requirements. Determination of the Respondent's good faith efforts shall include, but shall not be eliminated to, the following factors: The Respondent's employment and subcontracting policies, patterns and practices; affirmative advertising recruitment and training; technical assistance activities and such other reasonable activities or efforts as the Commission on Human Rights and Opportunities may prescribe that are designed to ensure the participation of minority business enterprises in municipal public works contracts or quasi-public agency projects. "Municipal public works project" means that portion of an agreement entered into on or after October 1, 2015, between any individual, firm or corporation and a municipality for the construction, rehabilitation, conversion, extension, demolition or repair of a public building, highway or other changes or improvements in real property, which is financed in whole or in part by the state, including, but not limited to, matching

expenditures, grants, loans, insurance or guarantees but excluding any project of an alliance district, as defined in section 10-262u, finance by the state funding in an amount equal to fifty thousand dollars or less. "Quasi-public agency project" means the construction, rehabilitation, conversion, extension, demolition or repair of a building or other changes or improvements in real property pursuant to a contract entered into on or after October 1, 2015, which is financed in whole or in part by a quasi-public agency using state funds, including, but not limited to, matching expenditures, grants, loans, insurance or guarantees.

If this Project is receiving state funding, the selected Respondent must comply with CONN. GEN. STAT. §§ 4a-60, 4a-60a, 4a-60g, and 46a-68b through 46a-68f, inclusive, as amended by June 2015 Special Session Public Act 15-5. An Affirmative Action Plan must be filed with and approved by the Commission on Human Rights and Opportunities prior to the commencement of construction. State law requires a minimum of twenty-five (25%) percent of the state-funded portion of the contract for award to subcontractors holding current certification from the Connecticut Department of Administrative Services ("DAS") under the provisions of CONN. GEN. STAT. § 4a-60g, as amended. (25% of the work with DAS certified Small and Minority owned businesses and 25% of that work with DAS certified Minority, Women and/or Disabled owned businesses.) The contractor must demonstrate good faith effort to meet the 25% set-aside goals. For municipal public works contracts and quasi-public agency projects, the contractor must file a written or electronic non-discrimination certification with the Commission on Human Rights and Opportunities. Forms can be found at:

http://www.ct.gov/opm/cwp/view.asp?a=2982&q=390928&opmNav_GID=1806.

The successful proposer shall comply with the requirements of Conn. Gen. Stat. § 31-52(b), as amended. Specifically, the successful proposer agrees that in the employment of labor to perform the work under the Contract, preference shall be given to citizens of the United States who are, and have been continuously for at least three (3) months prior to the date of the Contract, residents of the labor market area (as established by the State of Connecticut Labor Commissioner) in which such work is to be done, and if no such qualified person is available, then to citizens who have continuously resided in New Haven County for at least three (3) months prior to the date hereof, and then to citizens of the State who have continuously resided in the State at least three (3) months prior to the date of the Contract.

k. WORKERS COMPENSATION

Prior to Contract execution, the Town will require the tentative successful proposer to provide a current statement from the State Treasurer that, to the best of her knowledge and belief, as of the date of the statement, the tentative successful proposer was not liable to the State for any workers' compensation payments made pursuant to Conn. Gen. Stat. § 31-355.

l. SAFETY

The successful proposer and each of its permitted subcontractors shall furnish proof that each employee performing the work of a mechanic, laborer or worker under the Contract has completed a course of at least ten (10) hours in construction safety and health approved by the federal Occupational Safety and Health Administration or has completed a new miner training program approved by the Federal Mine Safety and Health Administration. Such proof shall be provided with the certified payroll submitted for the first week each such employee, mechanic, laborer, or worker begins work under the Contract.

m. COMPLIANCE WITH LAWS

The successful proposer shall comply with all applicable laws, regulations, ordinances, codes and orders of the United States, the State of Connecticut and the Town related to its proposal and the performance of the work described in the Contract, including but not limited to:

1. Non-Discrimination and Affirmative Action. Proposer, in performing under this contract, shall not discriminate against any worker, employee or applicant, or any member of the public, because of race, creed, color, age, marital status, sexual orientation, national origin, ancestry, sex, mental retardation or physical disability, including but not limited to blindness, unless it is shown by the Proposer that such disability prevents performance of the work involved in any manner prohibited by the laws of the United States or the State of Connecticut, nor otherwise commit an unfair employment practice. Proposer further agrees that this article, (and any additional provisions required by law), will be incorporated by Proposer in all contracts entered into with suppliers of materials or services contractors and sub-contractors and all labor organizations, furnishing skilled, unskilled and craft union skilled labor or who may perform any such labor or services in connection with this contract. The following principles and requirements of Equal Opportunity and Affirmative Action, as incorporated herein, will be incorporated into "Equal Opportunity - Non-Discrimination Clause" are hereby deemed to be included in all Town bid documents, purchase orders, lease and contracts entered into with the Town. The principles of Affirmative Action are addressed in the 13th, 14th and 15th Amendments of the United States Constitution, Civil Rights Act of 1964, Equal Pay Act of 1963, Title VI and VII of the 1964 United States Civil Rights Act, Presidential Executive Orders 11246, 11375, 11478 (nondiscrimination under federal contracts), Act 1, Section 1 and 20 of the Connecticut Constitution, Governor Grasso's Executive Order Number 11, Governor O'Neill's Executive Order Number 9, the Connecticut Fair Employment Practices Law (Sec. 46a-60-69) of the Connecticut General Statutes (CGS), Connecticut Code of Fair Practices (46a-70-81), Deprivation of Civil Rights (46a-58 (a)(d)), Public Accommodations Law (46a-63-64), Discrimination against Criminal Offenders (46a-80), definition of blind (46a-51(1)), definition of Physically Disabled (46a-51 (15)), definition of Mentally Retarded (46a-51-13), cooperation with the Commission on Human Rights and Opportunities (46a-77), Sexual Harassment (46a-60 (a)-8), Connecticut Credit Discrimination Law (360436 through 439), Title 1 of the State and the Local Fiscal Assistance Act 1 1972.

If a project is funded in whole or in part by State funds, CGS Sections 46a-68c through 46a-68k apply to contractors. These Sections trigger affirmative action plan requirements for contractors and the filing of compliance reports with the State by contractors.

2. Executive Orders. The contract may be subject to the provisions of Executive Order No. Three of Governor Thomas J. Meskill, promulgate June 16, 1971, concerning labor employment practices, Executive Order No. Seventeen of Governor Thomas J. Meskill, promulgate February 15, 1973, concerning the listing of employment opening and Executive Order No. Sixteen of Governor John G. Rowland promulgated August 4, 1999, concerning violence in the workplace, all of which are incorporated into and are made a part of the contract as if they had been fully set forth in it. The contract may also be subject to Executive Order No. 7C of Governor .

Jodi Rell, promulgated July 13, 2006, concerning contracting reforms and Executive Order No. 14 of Governor M. Jodi Rell, promulgated April 17, 2006, concerning procurement of cleaning products and services, in accordance with their respective terms and conditions.

3. Connecticut's Prevailing Wage Law Provision. If applicable, the Proposer must be in full compliance with CGS Section 31-53 and 31-53(a) which applies to each contract for the construction, remodeling, refinishing, refurbishing, rehabilitation, alteration, or repair of any public works project by the state or its agents, or by any political subdivision of the State, CGS Section 31-53 (g) provides monetary thresholds which must be met before the law is applicable. In accordance with CGS Section 31-53, projects are subject to the payment of minimum prevailing wages where the total cost of all work to be performed by all contractors and subcontractors in connection with new construction of any public works project is **\$1,000,000** or more and where the total cost of all work to be performed by all contractors and subcontractors in connection with any remodeling, refinishing, refurbishing, rehabilitation, alteration or repair of any public works project is **\$100,000** or more. For qualifying projects, all contractors and subcontractors shall submit to the Finance Department certified weekly payrolls for all contracts meeting the stated monetary limits. The certified payrolls shall be submitted to the Finance Department with the Proposer's monthly certificate for payment. The Proposers should familiarize themselves with all aspects of the provisions under state law in order to ensure full compliance.

4. Occupational Safety and Health Administration Requirements. According to CGS, Section 31-53b (a) each contract entered into on or after July 1, 2007, for the construction, remodeling, refinishing, refurbishing, rehabilitation, alteration or repair of any public building project by the state or any of its agents, or by a political subdivision of the state or any of its agents, where the total cost of all work to be performed by all contractors and subcontractors in connection with the contract is at least **\$100,000** shall contain a provision requiring that, not later than thirty days after the date such contract is awarded, each contractor furnish proof to the Labor Commissioner that all employees performing manual labor on or in such public building, pursuant to such contract, have completed a course of at least ten hours in duration in construction safety and health approved by the federal Occupational Safety and Health Administration or, in the case of telecommunications employees, have completed at least ten hours of training in accordance with 29 CFR 1910.268. The aforesaid provisions shall be deemed to be incorporated into the Contract with the Town. The contractors should familiarize themselves with all aspects of state law and any applicable regulations pertaining to these requirements in order to ensure full compliance.

5. Payment Bond/Performance Bond State Law Requirements. CGS Section 49-41, known as the Little Miller Act, requires that the Town ensure that payment bonds a/k/a labor and materials bond in the amount of the contract are provided for public works projects over **\$100,000**. When a contract for construction, alteration, remodeling, repair or demolition of any public building is estimated to cost more than **\$500,000** additional laws/requirements apply. The contractors should familiarize themselves with all aspects of state law and any applicable regulations pertaining to these requirements in order to ensure full compliance.

6. State of Connecticut Contractor Prequalification Program. CGS Section 4b-91 requires all bidders for the construction, alteration, remodeling, repair or demolition of any public building or any other public work by a public agency (includes a municipality) that is paid for, in whole or in part, with state funds and that is estimated to cost more than **\$500,000**, except a public highway or bridge project or any other construction project administered by DOT, shall be prequalified with the State pursuant to CGS Section 4a-100. Once a contractor is prequalified, it is issued a prequalification certificate by DAS, which certificate is in effect for one year. Subcontractors' work, the cost of which may exceed **\$500,000**, are also required to be prequalified. Any bid for a project that requires prequalification must include a copy of the bidder's Prequalification Certificate showing the aggregate work capacity rating required under the contract and the Update (Bid) Statement showing renewal of certificate and/or change in aggregate work capacity. Bids which do not include a copy of the Prequalification Certificate and the Update (Bid) Statement are invalid. Contractors should contact the State Department of Administrative Services to familiarize themselves with these requirements.

7. Non-Resident Contractor 5% Tax for Contracts.

CGS Section 12-430(7) requires non-resident contractors who perform services or furnish materials, or both, for the construction, alteration or improvement of any project in which the contract price is at least **\$250,000**, to furnish the Department of Revenue Services (DRS) a Guarantee Bond for 5% of the total cost of the work, issued under a contract using Form AU-766, Guarantee Bond. This form is available on the State DRS website. Form AU-766 must be submitted for each additional change order or supplement issued against the contract. Non-resident contractors must have completed and submitted to the DRS Form REG-1, Business Tax Registration Application, to register with the DRS and have been issued a Connecticut Tax Registration Number. This form is available on the DRS website. Non-resident contractors have 120 days from the commencement of the contract to file the Guarantee Bond with the State. Commencement of the contract, as defined by law, "means the time when the non-resident contractor signs the contract, but, in any event, occurs no later than when the work under the contract actually starts." As soon as the guarantee bond is filed with the DRS, the non-resident contractor shall submit the copy of such Guarantee Bond together with the non-resident contractor's Connecticut Tax Registration Number to the Town department for whom the project is required. After the non-resident contractor receives its Certificate of Compliance from the DRS confirming that the Guarantee Bond requirement has been met, the non-resident contractor shall submit a copy of the same to the department, for whom the work is being performed, with a copy to the Purchasing Department.

8. Equal Employment Opportunity (EEO); Minority Business Enterprises (MBE)

If a project is funded in whole or in part by state or federal funds, there may be a requirement that the contractor comply with CGS Section 4a-60 and applicable State regulations. On these projects it will depend upon which set-aside requirements are imposed by the funding agency. If no set-aside requirement is imposed, a statement that the Proposer is required to undertake good faith efforts to include subcontractors and suppliers who are minority business enterprises will suffice and shall be deemed to be incorporated into the Contract with the Town. If there is a set-aside goal, the Town and Proposer shall comply with the Small Contractors Set-Aside Program and

the hiring goals identified by the State Commission on Human Rights and Opportunities (CHRO.)

9. If a project or program is funded in whole or in part with federal funds, the Federal Uniform Guidance Procurement Standards, 2 CFR §§ 200.317-200.327, shall apply and full compliance by Proposer with same shall be required.

n. LICENSES AND PERMITS

The successful proposer certifies that, throughout the Contract term, it shall have and provide proof of all approvals, permits and licenses required by the Town and/or any state or federal authority. The successful proposer shall immediately and in writing notify the Town of the loss or suspension of any such approval, permit or license.

o. AMENDMENTS

The Contract may not be altered or amended except by the written agreement of both parties.

p. ENTIRE AGREEMENT

It is expressly understood and agreed that the Contract contains the entire agreement between the parties, and that the parties are not, and shall not be, bound by any stipulations, representations, agreements or promises, oral or otherwise, not printed or inserted in the Contract or its attached exhibits.

q. VALIDITY

The invalidity of one or more of the phrases, sentences or clauses contained in the Contract shall not affect the remaining portions so long as the material purposes of the Contract can be determined and effectuated.

r. CONNECTICUT LAW AND COURTS

The Contract shall be governed by and construed in accordance with the internal laws (as opposed to the conflicts of law provisions) of the State of Connecticut, and the parties irrevocably submit in any suit, action or proceeding arising out of the Contract to the jurisdiction of the United States District Court for the District of Connecticut or of any court of the State of Connecticut, as applicable.

s. NON-EMPLOYMENT RELATIONSHIP

The Town and the successful proposer are independent parties. Nothing contained in the Contract shall create, or be construed or deemed as creating, the relationships of principal and agent, partnership, joint venture, employer and employee, and/or any relationship other than that of independent parties contracting with each other solely for the purpose of carrying out the terms and conditions of the Contract. The successful proposer understands and agrees that it is not entitled to employee benefits, including but not limited to workers compensation and employment insurance coverage, and disability. The successful proposer shall be solely responsible for any applicable taxes.

END OF STANDARD INSTRUCTIONS TO PROPOSERS

TOWN OF CHESHIRE, CONNECTICUT

SPECIFICATIONS FOR
RENOVATION TO EXISTING BATHROOM AT QUINNIPIAC PARK
1325 CHESHIRE STREET, CHESHIRE, CT
PROPOSAL #2122-10
MARCH 7, 2022

END OF SPECIFICATIONS

TOWN OF CHESHIRE, CONNECTICUT

RENOVATION TO EXISTING BATHROOM AT QUINNIAC PARK
PROPOSAL #2122-10

The successful bidder agrees to maintain in force at all times during the Contract the following coverages placed with company(ies) licensed by the State of Connecticut which have at least an “A-” VIII policyholders rating according to Best Publication’s latest edition Key Rating Guide.

		(Minimum Limits)
General Liability*	Each Occurrence	\$1,000,000
	General Aggregate	\$2,000,000
	Products/Completed Operations Aggregate	\$2,000,000
Auto Liability*	Combined Single Limit	
	Each Accident	\$1,000,000
Umbrella* (Excess Liability)	Each Occurrence	\$1,000,000
	Aggregate	\$1,000,000

* The Town of Cheshire shall be named as “Additional Insured.” Coverage is to be provided on a primary, noncontributory basis. Waiver of subrogation must be provided. If any policy is written on a “Claims Made” basis, the policy must be continually renewed for a minimum of two (2) years from the completion date of the Contract. If the policy is replaced and/or the retroactive date is changed, then the expiring policy must be endorsed to extend the reporting period for claims for the policy in effect during the Contract for two (2) years from the completion date.

Workers’ Compensation and WC Statutory Limits

Employers’ Liability	EL Each Accident	\$100,000
	EL Disease Each Accident	\$100,000
	EL Disease Policy Limit	\$500,000

Original, completed Certificates of Insurance must be presented to the Town prior to Contract execution. The successful bidder agrees to provide replacement/renewal certificates at least 60 days prior to the expiration of the policy. Should any of the above described policies be cancelled before the expiration date, written notice must be given to the Town thirty (30) days prior to cancellation.

END OF INSURANCE REQUIREMENTS

TOWN OF CHESHIRE, CONNECTICUT

PROPOSAL FORM
RENOVATION TO EXISTING BATHROOM AT QUINNIPIAC PARK
1325 CHESHIRE STREET, CHESHIRE, CT
PROPOSAL #2122-10
MARCH 7, 2022

PROPOSER'S FULL LEGAL NAME:

Pursuant to and in full compliance with the RFP, the undersigned proposer, having visited the site or property if applicable, and having thoroughly examined each and every document comprising the *RFP*, including any addenda, hereby offers and agrees as follows:

To provide the products and/or services specified in, and upon the terms and conditions of, the RFP for the total sum of _____
-----'---"/100 Dollars (write out in words) (\$ _____),

ACKNOWLEDGEMENT

In submitting this Proposal Form, the undersigned proposer acknowledges that the price(s) include all labor, materials, transportation, hauling, overhead, fees and insurances, bonds or letters of credit, profit, security, permits and licenses, and all other costs to cover the completed work called for in the RFP. Except as otherwise expressly stated in the RFP, no additional payment of any kind will be made for work accomplished under the price(s) as proposed.

REQUIRED DISCLOSURES

a. **Exceptions to the RFP**

This proposal does not take exception to any requirement of the RFP, including but not only any of the Contract Terms set forth in Section 26 of the Standard Instructions to Proposers.

OR

This proposal takes exception(s) to certain of the RFP requirements, including but not only the following Contract Terms set forth in Section 26 of the Standard Instructions to Proposers. **Attached is a sheet fully describing each such exception.**

b. State Debarment List

Is the proposer on the State of Connecticut's Debarment List?

_____ **Yes**
_____ **No**

c. Occupational Safety and Health Law Violations

Has the proposer or any firm, corporation, partnership or association in which i.thas an interest (1) been cited for three (3) or more willful or serious violations of any occupational safety and health act or of any standard, order or regulation promulgated pursuant to such act, during the three-year period preceding the proposal (provided such violations were cited in accordance with the provisions of any state occupational safety and health act or the Occupational Safety and Health Act of 1970, and not abated within the time fixed by the citation and such citation has not been set aside following appeal to the appropriate agency or court having jurisdiction) or (2) received one or more criminal convictions related to the injury or death of any employee in the three-year period preceding the proposal?

_____ **Yes**
_____ **No**

If "yes," attach a sheet fully describing each such matter.

d. Arbitration/Litigation

Has either the proposer or any of its principals (regardless of place of employment) been involved for the most recent ten (10) years in any resolved or pending arbitration or litigation?

_____ **Yes**
_____ **No**

If "yes," attach a sheet fully describing each such matter.

(Next Two (2)Pages Intentionally Left Blank)

e. Criminal Proceedings

Has the proposer or any of its principals (regardless of place of employment) ever been the subject of any criminal proceedings?

_____ **Yes**
_____ **No**

If "yes," attach a sheet fully describing each such matter.

f. Has the proposer failed to complete work awarded to it or been declared in default in the past 5 years?

_____ Yes
_____ No

g. Ethics and Offenses in Public Projects or Contracts

Has either the proposer or any of its principals (regardless of place of employment) ever been found to have violated any state or local ethics law, regulation, ordinance, code, policy or standard, or to have committed any other offense arising out of the submission of proposals or bids or the performance of work on public works projects or contracts?

_____ Yes
_____ No

If "yes," attach a sheet fully describing each such matter.

PROPOSAL BID SECURITY

I/we have included herein the required proposal (bid) bond in the amount of **10% of the proposal amount.**

NOTE: THIS DOCUMENT, IN ORDER TO BE CONSIDERED A VALID PROPOSAL, MUST BE SIGNED BY A PRINCIPAL OFFICER OR OWNER OF THE BUSINESS ENTITY THAT IS SUBMITTING THE PROPOSAL. SUCH SIGNATURE CONSTITUTES THE PROPOSER'S REPRESENTATIONS THAT IT HAS READ, UNDERSTOOD AND FULLY ACCEPTED EACH AND EVERY PROVISION OF EACH DOCUMENT COMPROMISING THE RFP, UNLESS AN EXCEPTION IS DESCRIBED ABOVE. PROPOSER AGREES THAT IT WILL SIGN CONTRACT PROVIDED BY THE TOWN, WITHOUT MODIFICATIONS OR ALTERATIONS, WITHIN FIVE (5) DAYS OF AWARD.

BY.....
(PRINT NAME)

TITLE:.....

(SIGNATURE)

DATE:.....

END OF PROPOSAL FORM

TOWN OF CHESHIRE, CONNECTICUT

PROPOSER'S LEGAL STATUS DISCLOSURE

Please fully complete the applicable section below, attaching a separate sheet if you need additional space.

For purposes of this disclosure, "permanent place of business" means an office continuously maintained, occupied and used by the proposer's regular employees regularly in attendance to carry on the proposer's business in the proposer's own name. An office maintained, occupied and used by a proposer only for the duration of a contract will not be considered a permanent place of business. An office maintained, occupied and used by a person affiliated with a proposer will not be considered a permanent place of business of the proposer.

IF A SOLELY OWNED BUSINESS:

Proposer's Full Legal Name _____

Street Address _____

Mailing Address (if different from Street Address) _____

Owner's Full Legal Name _____

Number of years engaged in business under sole proprietor or trade name _____

Does the proposer have a "permanent place of business" in Connecticut, as defined above?

_____ Yes _____ No

If yes, please state the full street address (not a post office box) of that "permanent place of business."

IF A CORPORATION:

Proposer's Full Legal Name _____

Street Address _____

Mailing Address (if different from Street Address) _____

Owner's Full Legal Name _____

Number of years engaged in business _____

Names of Current Officers

President

Secretary

Chief Financial Officer

Does the proposer have a "permanent place of business" in Connecticut, as defined above?

Yes

No

If yes, please state the full street address (not a post office box) of that "permanent place of business."

IF A LIMITED LIABILITY COMPANY:

Proposer's Full Legal Name _____

Street Address _____

Mailing Address (if different from Street Address) _____

Owner's Full Legal Name _____

Number of years engaged in business _____

Names of Current Manager(s) and Member(s) ·

Name & Title (if any) Residential Address (street only)

Name & Title (if any) Residential Address (street only)

Name & Title (if any) Residential Address (street only)

Name & Title (if any) Residential Address (street only)

Name & Title (if any) Residential Address (street only)

Does the proposer have a "permanent place of business" in Connecticut, as defined above?

Yes _____ No _____

If yes, please state the full street address (not a post office box) of that "permanent place of business."

IF A PARTNERSHIP:

Proposer's Full Legal Name _____

Street Address _____

Mailing Address (if different from Street Address) _____

Owner's Full Legal Name _____

Number of years engaged in business _____

Names of Current Partners

Name & Title (if any) Residential Address (street only)

Name & Title (if any) Residential Address (street only)

Name & Title (if any) Residential Address (street only)

Name & Title (if any) Residential Address (street only)

Does the proposer have a "permanent place of business" in Connecticut, as defined above?

_____ Yes

_____ No

If yes, please state the full street address (not a post office box) of that "permanent place of business."

Sign on the next page

Proposer's Full Legal Name

(print)

Name and Title of Proposer's Authorized Representative

(signature)

Proposer's Representative, Duly Authorized

Date: _____

END OF LEGAL STATUS DISCLOSURE FORM

TOWN OF CHESHIRE, CONNECTICUT

**PROPOSAL #2122-10
RENOVATION TO EXISTING BATHROOM AT QUINNIPIAC PARK
1325 CHESHIRE STREET, CHESHIRE, CT**

PROPOSER'S CERTIFICATION

**Concerning Equal Employment Opportunities
And Affirmative Action Policy**

I/we, the proposer, certify that:

- 1) I/we are in compliance with the equal opportunity clause as set forth in Connecticut state law (Executive Order No. Three, <http://www.cslib.org/xeorder3.htm>).
- 2) I/we do not maintain segregated facilities.
- 3) I/we have filed all required employer's information reports.
- 4) I/we have developed and maintain written affirmative action programs.
- 5) I/we list job openings with federal and state employment services.
- 6) I/we attempt to employ and advance in employment qualified handicapped individuals.
- 7) I/we are in compliance with the Americans with Disabilities Act.
- 8) I/we (check one):
 have an Affirmative Action Program, or

 employ 10 people or fewer.
- 9) I/we have read and understand the RFP Documents and all addenda and our proposal has been made on the basis thereof.

Legal Name of Proposer

(signature)

Proposer's Representative, Duly Authorized

Name of Proposer's Authorized
Representative

Title of Proposer's Authorized Representative

Date

TOWN OF CHESHIRE, CONNECTICUT

PROPOSER'S NON COLLUSION AFFIDAVIT

**PROPOSAL FOR: RENOVATION TO EXISTING BATHROOM AT QUINNIPIAC PARK
1325 CHESHIRE STREET, CHESHIRE, CT**

PROPOSAL NUMBER: #2122-10

The undersigned proposer, having fully informed himself/herself/itself regarding the accuracy of the statements made herein, certifies that:

- (1) the proposal is genuine; it is not a collusive or sham proposal;
- (2) the proposer developed the proposal independently and submitted it without collusion with, and without any agreement, understanding, communication or planned common course of action with, any other person or entity designed to limit independent competition;
- (3) the proposer, its employees and agents have not communicated the contents of the proposal to any person not an employee or agent of the proposer and will not communicate the proposal to any such person prior to the official opening of the proposal; and
- (4) no elected or appointed official or other officer or employee of the Town of Cheshire is directly or indirectly interested in the proposer's proposal, or in the supplies, materials, equipment, work or labor to which it relates, or in any of the profits thereof.

The undersigned proposer further certifies that this affidavit is executed for the purpose of inducing the Town of Cheshire to consider its proposal and make an award in accordance therewith.

Legal Name of Proposer

(signature)

Proposer's Representative, Duly Authorized

Name of Proposer's Authorized
Representative

Title of Proposer's Authorized Representative

Date

Subscribed and sworn to before me this ____ day of _____, 20__.

Notary Public
My Commission Expires:

TOWN OF CHESHIRE, CONNECTICUT
PROPOSAL #2122-10
RENOVATION TO EXISTING BATHROOM AT QUINNIPIAC PARK
1325 CHESHIRE STREET, CHESHIRE, CT

PROPOSER'S STATEMENT OF REFERENCES

Provide at least three (3) references:

1. BUSINESS NAME.....
ADDRESS.....
CITY, STATE
TELEPHONE:
INDIVIDUAL CONTACT NAME AND POSITION _ _ _ _ _

2. BUSINESS NAME.....
ADDRESS.....
CITY, STATE.....
TELEPHONE:
INDIVIDUAL CONTACT NAME AND POSITION _ _ _ _ _

3. BUSINESS NAME.....
ADDRESS.....
CITY, STATE
TELEPHONE:
INDIVIDUAL CONTACT NAME AND POSITION _ _ _ _ _

END OF STATEMENT OF REFERENCES

CONTRACT FOR (DESCRIBE SUBJECT MATTER/

This Contract is made as of the ____ day of _____, 20__ (the "Effective Date"), by and between the Town of Cheshire, 84 South Main Street, Cheshire, Connecticut, a municipal corporation organized and existing under the laws of the State of Connecticut (the "Town"), and [name and address of successful proposer/ (the "Contracting Party")-

RECITALS:

WHEREAS, the Town has issued a Request for Proposals for [describe subject matter/ (the "RFP"), a copy of which, along with any addenda, is attached as Exhibit A;

WHEREAS, the Contracting Party submitted a proposal to the Town dated _____ (the "Proposal"), a copy of which is attached as Exhibit B;

WHEREAS, the Town has selected the Contracting Party to perform the Work (as defined in Section 1 below); and

WHEREAS, the Town and the Contracting Party desire to enter into a formal contract for the performance of the Work.

NOW THEREFORE, in consideration of the recitals set forth above and the parties' mutual promises and obligations contained below, the parties agree as follows:

1. Work: The Contracting Party agrees to perform the Work described more fully in the attached Exhibits A and B *{Note: If the Proposal has taken any exceptions to the RFP, this provision should be amended to include specific statements about whether the Town has accepted or rejected those exceptions - whether they are contrary to or in addition to the RFP's terms. This is critically important, and we urge you to contact the Town Attorney for assistance on this additional required language.}* (collectively, the "Work").

The Contracting Party also agrees to comply with all of the terms and conditions set forth herein and in the RFP, including but not only **all of the terms set forth in Section 26 (the "Contract Terms") of the Standard Instructions to Bidders.**

2. Term: *[placeholder - will vary from contract to contract]*

3. Contract Includes Exhibits; Order of Construction: The Contract includes the RFP (Exhibit A) and the Proposal (Exhibit B), which are made a part hereof. In the event of a conflict or inconsistency between or among this document, the RFP, and the Proposal, this document shall have the highest priority, the RFP the second priority, and the Proposal the third priority.

4. Price and Payment: *[placeholder - will vary from contract to contract. If contract extends beyond current fiscal year, be sure to include non-appropriation language.]*

5. Right to Terminate - If the Contracting Party's fails to comply with any of the terms, provisions or conditions of the Contract, including the exhibits, the Town shall have the right, in addition to all other available remedies, to declare the Contract in default and, therefore, to terminate it and to resubmit the subject matter of the Contract to further public procurement. In that event, the Contracting Party shall pay the Town, as liquidated damages, the amount of any excess of the price of the new contract over the Contract price provided for herein, plus any legal or other costs or expenses incurred by the Town in terminating this Contract and securing a new contracting party.

6. No Waiver or Estoppel - Either party's failure to insist upon the strict performance by the other of any of the terms, provisions and conditions of the Contract shall not be a waiver or create an estoppel. Notwithstanding any such failure, each party shall have the right thereafter to insist upon the other party's strict performance, and neither party shall be relieved of such obligation because of the other party's failure to comply with or otherwise to enforce or to seek to enforce any of the terms, provisions and conditions hereof.

7. Notice - Any notices provided for hereunder shall be given to the parties in writing (which may be hardcopy, facsimile, or e-mail) at their respective addresses set forth below:

If to the Town:

[name, address, fax and e-mail]

If to the Contracting Party:

[name, address, fax and e-mail]

8. Execution - This Contract may be executed in one or more counterparts, each of which shall be considered an original instrument, but all of which shall be considered one and the same agreement, and shall become binding when one or more counterparts have been signed by each of the parties hereto and delivered (including delivery by facsimile) to each of the parties.

IN WITNESS THEREOF, the parties have executed this contract as of the last date signed below.

TOWN OF CHESHIRE

By _____
Sean M. Kimball
Its Town Manager, Duly
Authorized Date: _____

[CONTRACTING PARTY LEGAL
NAME]

By _____
Its _____, Duly
Authorized
Date:

Minimum Rates and Classifications for Building Construction

ID#: 22-32275

**Connecticut Department of Labor
Wage and Workplace Standards Division**

By virtue of the authority vested in the Labor Commissioner under provisions of Section 31-53 of the General Statutes of Connecticut, as amended, the following are declared to be the prevailing rates and welfare payments and will apply only where the contract is advertised for bid within 20 days of the date on which the rates are established. Any contractor or subcontractor not obligated by agreement to pay to the welfare and pension fund shall pay this amount to each employee as part of his/her hourly wages.

Project Number: #2122-10

Project Town: Cheshire

State#: #2122-10

FAP#: Cheshire

Project: Quinnipiac Park Bathroom Renovation (Cheshire)

CLASSIFICATION	Hourly Rate	Benefits
1b) Asbestos/Toxic Waste Removal Laborers: Asbestos removal and encapsulation (except its removal from mechanical systems which are not to be scrapped), toxic waste removers, blasters.**See Laborers Group 7**		
1c) Asbestos Worker/Heat and Frost Insulator	43.72	30.99
2) Boilermaker	38.34	26.01
3a) Bricklayer, Cement Mason, Concrete Finisher (including caulking), Stone Masons	37.75	34.62 + a
3b) Tile Setter	37.1	30.52
3c) Terrazzo Mechanics and Marble Setters	31.69	22.35
3d) Tile, Marble & Terrazzo Finishers	31.07	24.23
3e) Plasterer	33.48	32.06
-----LABORERS-----		
4) Group 1: Laborers (common or general), acetylene burners, concrete specialists, wrecking laborers, fire watchers.	31.5	23.25
4a) Group 2: Mortar mixers, plaster tender, power buggy operators, powdermen, fireproofers/mixer/nozzleman (Person running mixer and spraying fireproof only).	31.75	23.25

Project: Quinnipiac Park Bathroom Renovation (Cheshire)

4b) Group 3: Jackhammer operators/pavement breaker, mason tender (brick), mason tender (cement/concrete), forklift operators and forklift operators (masonry).	32.0	23.25
4c) **Group 4: Pipelayers (Installation of water, storm drainage or sewage lines outside of the building line with P6, P7 license) (the pipelayer rate shall apply only to one or two employees of the total crew who primary task is to actually perform the mating of pipe sections) P6 and P7 rate is \$26.80.	32.5	23.25
4d) Group 5: Air track operator, sand blaster and hydraulic drills.	32.25	23.25
4e) Group 6: Blasters, nuclear and toxic waste removal.	34.5	23.25
4f) Group 7: Asbestos/lead removal and encapsulation (except it's removal from mechanical systems which are not to be scrapped).	32.5	23.25
4g) Group 8: Bottom men on open air caisson, cylindrical work and boring crew.	29.78	23.25
4h) Group 9: Top men on open air caisson, cylindrical work and boring crew.	29.24	23.25
4i) Group 10: Traffic Control Signalman	18.0	23.25
5) Carpenter, Acoustical Ceiling Installation, Soft Floor/Carpet Laying, Metal Stud Installation, Form Work and Scaffold Building, Drywall Hanging, Modular-Furniture Systems Installers, Lathers, Piledrivers, Resilient Floor Layers.	35.57	25.65
5a) Millwrights	36.32	26.81
6) Electrical Worker (including low voltage wiring) (Trade License required: E1,2 L-5,6 C-5,6 T-1,2 L-1,2 V-1,2,7,8,9)	39.6	31.21+3% of gross wage
7a) Elevator Mechanic (Trade License required: R-1,2,5,6)	58.9	36.885+a+b
-----LINE CONSTRUCTION-----		
Groundman	26.5	6.5% + 9.00
Linemen/Cable Splicer	48.19	6.5% + 22.00
8) Glazier (Trade License required: FG-1,2)	39.98	22.90 + a

As of: March 3, 2022

9) Ironworker, Ornamental, Reinforcing, Structural, and Precast Concrete Erection	38.17	38.02 + a
----OPERATORS----		
Group 1: Crane handling or erecting structural steel or stone, hoisting engineer 2 drums or over, front end loader (7 cubic yards or over), work boat 26 ft. and over and Tunnel Boring Machines. (Trade License Required)	43.88	25.80 + a
Group 2: Cranes (100 ton rate capacity and over); Excavator over 2 cubic yards; Piledriver (\$3.00 premium when operator controls hammer); Bauer Drill/Caisson. (Trade License Required)	43.53	25.80 + a
Group 3: Excavator; Backhoe/Excavator under 2 cubic yards; Cranes (under 100 ton rated capacity), Grader/Blade; Master Mechanic; Hoisting Engineer (all types of equipment where a drum and cable are used to hoist or drag material regardless of motive power of operation), Rubber Tire Excavator (Drott-1085 or similar); Grader Operator; Bulldozer Fine Grade. (slopes, shaping, laser or GPS, etc.). (Trade License Required)	42.72	25.80 + a
Group 4: Trenching Machines; Lighter Derrick; Concrete Finishing Machine; CMI Machine or Similar; Koehring Loader (Skooper).	42.3	25.80 + a
Group 5: Specialty Railroad Equipment; Asphalt Paver; Asphalt Reclaiming Machine; Line Grinder; Concrete Pumps; Drills with Self Contained Power Units; Boring Machine; Post Hole Digger; Auger; Pounder; Well Digger; Milling Machine (over 24	41.65	25.80 + a
Group 5 continued: Side Boom; Combination Hoe and Loader; Directional Driller; Pile Testing Machine.	41.65	25.80 + a
Group 6: Front End Loader (3 up to 7 cubic yards); Bulldozer (rough grade dozer).	41.31	25.80 + a
Group 7: Asphalt roller, concrete saws and cutters (ride on types), vermeer concrete cutter, Stump Grinder; Scraper; Snooper; Skidder; Milling Machine (24	40.94	25.80 + a
Group 8: Mechanic, grease truck operator, hydroblaster; barrier mover; power stone spreader; welding; work boat under 26 ft.; transfer machine.	40.51	25.80 + a
Group 9: Front end loader (under 3 cubic yards), skid steer loader regardless of attachments, (Bobcat or Similar): forklift, power chipper; landscape equipment (including Hydroseeder).	40.04	25.80 + a
Group 10: Vibratory hammer; ice machine; diesel and air, hammer, etc.	37.81	25.80 + a
Group 11: Conveyor, earth roller, power pavement breaker (whiphammer), robot demolition equipment.	37.81	25.80 + a

Project: Quinnipiac Park Bathroom Renovation (Cheshire)

Group 12: Wellpoint operator.	37.74	25.80 + a
Group 13: Compressor battery operator.	37.11	25.80 + a
Group 14: Elevator operator; tow motor operator (solid tire no rough terrain).	35.87	25.80 + a
Group 15: Generator Operator; Compressor Operator; Pump Operator; Welding Machine Operator; Heater Operator.	35.43	25.80 + a
Group 16: Maintenance Engineer/Oiler.	34.72	25.80 + a
Group 17: Portable asphalt plant operator; portable crusher plant operator; portable concrete plant operator.	39.42	25.80 + a
Group 18: Power safety boat; vacuum truck; zim mixer; sweeper; (Minimum for any job requiring a CDL license).	36.77	25.80 + a
-----PAINTERS (Including Drywall Finishing)-----		
10a) Brush and Roller	36.42	22.90
10b) Taping Only/Drywall Finishing	37.17	22.90
10c) Paperhanger and Red Label	36.92	22.90
10e) Blast and Spray	39.42	22.90
11) Plumber (excluding HVAC pipe installation) (Trade License required: P-1,2,6,7,8,9 J-1,2,3,4 SP-1,2)	45.83	33.50
12) Well Digger, Pile Testing Machine	37.26	24.05 + a
13) Roofer (composition)	39.5	21.95
14) Roofer (slate & tile)	40.0	21.95
15) Sheetmetal Worker (Trade License required for HVAC and Ductwork: SM-1,SM-2,SM-3,SM-4,SM-5,SM-6)	40.08	40.53
16) Pipefitter (Including HVAC work) (Trade License required: S-1,2,3,4,5,6,7,8 B-1,2,3,4 D-1,2,3,4, G-1, G-2, G-8 & G-9)	45.83	33.50

As of: March 3, 2022

-----TRUCK DRIVERS-----

17a) 2 Axle	30.16	27.16 + a
17b) 3 Axle, 2 Axle Ready Mix	30.27	27.16 + a
17c) 3 Axle Ready Mix	30.33	27.16 + a
17d) 4 Axle, Heavy Duty Trailer up to 40 tons	30.39	27.16 + a
17e) 4 Axle Ready Mix	30.44	27.16 + a
17f) Heavy Duty Trailer (40 Tons and Over)	30.66	27.16 + a
17g) Specialized Earth Moving Equipment (Other Than Conventional Type on-the-Road Trucks and Semi-Trailers, Including Euclids)	30.44	27.16 + a
18) Sprinkler Fitter (Trade License required: F-1,2,3,4)	47.55	26.60 + a
19) Theatrical Stage Journeyman	25.76	7.34

Project: Quinnipiac Park Bathroom Renovation (Cheshire)

Welders: Rate for craft to which welding is incidental.

**Note: Hazardous waste removal work receives additional \$1.25 per hour for truck drivers.*

***Note: Hazardous waste premium \$3.00 per hour over classified rate*

ALL Cranes: When crane operator is operating equipment that requires a fully licensed crane operator to operate he receives an extra \$4.00 premium in addition to the hourly wage rate and benefit contributions:

- 1) Crane handling or erecting structural steel or stone; hoisting engineer (2 drums or over)***
- 2) Cranes (100 ton rate capacity and over) Bauer Drill/Caisson***
- 3) Cranes (under 100 ton rated capacity)***

Crane with 150 ft. boom (including jib) - \$1.50 extra

Crane with 200 ft. boom (including jib) - \$2.50 extra

Crane with 250 ft. boom (including jib) - \$5.00 extra

Crane with 300 ft. boom (including jib) - \$7.00 extra

Crane with 400 ft. boom (including jib) - \$10.00 extra

All classifications that indicate a percentage of the fringe benefits must be calculated at the percentage rate times the "base hourly rate".

Apprentices duly registered under the Commissioner of Labor's regulations on "Work Training Standards for Apprenticeship and Training Programs" Section 31-51-d-1 to 12, are allowed to be paid the appropriate percentage of the prevailing journeymen hourly base and the full fringe benefit rate, providing the work site ratio shall not be less than one full-time journeyman instructing and supervising the work of each apprentice in a specific trade.

The Prevailing wage rates applicable to this project are subject to annual adjustments each July 1st for the duration of the project.

Each contractor shall pay the annual adjusted prevailing wage rate that is in effect each July 1st, as posted by the Department of Labor.

It is the contractor's responsibility to obtain the annual adjusted prevailing wage rate increases directly from the Department of Labor's website.

The annual adjustments will be posted on the Department of Labor's Web page: www.ct.gov/dol. For those without internet access, please contact the division listed below.

The Department of Labor will continue to issue the initial prevailing wage rate schedule to the Contracting Agency for the project.

All subsequent annual adjustments will be posted on our Web Site for contractor access.

Contracting Agencies are under no obligation pursuant to State labor law to pay any increase due to the annual adjustment provision.

Effective October 1, 2005 - Public Act 05-50: any person performing the work of any mechanic, laborer, or worker shall be paid prevailing wage

All Person who perform work ON SITE must be paid prevailing wage for the appropriate mechanic, laborer, or worker classification.

All certified payrolls must list the hours worked and wages paid to All Persons who perform work ON SITE regardless of their ownership i.e.: (Owners, Corporate Officers, LLC Members, Independent Contractors, et. al)

Reporting and payment of wages is required regardless of any contractual relationship alleged to exist between the contractor and such person.

As of: March 3, 2022

Project: Quinnipiac Park Bathroom Renovation (Cheshire)

~~Unlisted classifications needed for work not included within the scope of the classifications listed may be added after award only as provided in the labor standards contract clause (29 CFR 5.5 (a) (1) (ii)).

Please direct any questions which you may have pertaining to classification of work and payment of prevailing wages to the Wage and Workplace Standards Division, telephone (860)263-6790.

As of: March 3, 2022

DRAFT AIA® Document A101™ - 2017

Standard Form of Agreement Between Owner and Contractor where the basis of payment is a Stipulated Sum

AGREEMENT made as of the « » day of « » in the year « »
(In words, indicate day, month and year.)

BETWEEN the Owner:
(Name, legal status, address and other information)

« » « Town of Cheshire
»84 South Main Street
Cheshire, CT 06410 »
« »
« »
« »

and the Contractor:
(Name, legal status, address and other information)

« » « »
« »
« »
« »

for the following Project:
(Name, location and detailed description)

« Renovation to Existing Bathroom at Quinnipiac Park 2122-10
1325 Cheshire St, Cheshire, CT 06410»
« »
« »

The Architect:
(Name, legal status, address and other information)

« «« WOJAS.ARCH, LLC
5 Race Track Hollow
Middlefield, CT 06455 »« »
« »
« »
« »

The Owner and Contractor agree as follows.

ADDITIONS AND DELETIONS:
The author of this document has added information needed for its completion. The author may also have revised the text of the original AIA standard form. An *Additions and Deletions Report* that notes added information as well as revisions to the standard form text is available from the author and should be reviewed.

This document has important legal consequences. Consultation with an attorney is encouraged with respect to its completion or modification.

The parties should complete A101™-2017, Exhibit A, Insurance and Bonds, contemporaneously with this Agreement. AIA Document A201™-2017, General Conditions of the Contract for Construction, is adopted in this document by reference. Do not use with other general conditions unless this document is modified.

ELECTRONIC COPYING of any portion of this AIA® Document to another electronic file is prohibited and constitutes a violation of copyright laws as set forth in the footer of this document.

TABLE OF ARTICLES

- 1 THE CONTRACT DOCUMENTS
- 2 THE WORK OF THIS CONTRACT
- 3 DATE OF COMMENCEMENT AND SUBSTANTIAL COMPLETION
- 4 CONTRACT SUM
- 5 PAYMENTS
- 6 DISPUTE RESOLUTION
- 7 TERMINATION OR SUSPENSION
- 8 MISCELLANEOUS PROVISIONS
- 9 ENUMERATION OF CONTRACT DOCUMENTS

EXHIBIT A INSURANCE AND BONDS

ARTICLE 1 THE CONTRACT DOCUMENTS

The Contract Documents consist of this Agreement, Conditions of the Contract (General, Supplementary, and other Conditions), Drawings, Specifications, Addenda issued prior to execution of this Agreement, other documents listed in this Agreement, and Modifications issued after execution of this Agreement, all of which form the Contract, and are as fully a part of the Contract as if attached to this Agreement or repeated herein. The Contract represents the entire and integrated agreement between the parties hereto and supersedes prior negotiations, representations, or agreements, either written or oral. An enumeration of the Contract Documents, other than a Modification, appears in Article 9.

ARTICLE 2 THE WORK OF THIS CONTRACT

The Contractor shall fully execute the Work described in the Contract Documents, except as specifically indicated in the Contract Documents to be the responsibility of others.

ARTICLE 3 DATE OF COMMENCEMENT AND SUBSTANTIAL COMPLETION

§ 3.1 The date of commencement of the Work shall be:

(Check one of the following boxes.)

The date of this Agreement.

A date set forth in a notice to proceed issued by the Owner or Architect. Contractor shall coordinate the scheduling and performance of the Work with the Owner.

Established as follows:

(Insert a date or a means to determine the date of commencement of the Work.)

If a date of commencement of the Work is not selected, then the date of commencement shall be the date of this Agreement.

§ 3.2 The Contract Time shall be measured from the date of commencement of the Work.

§ 3.3 Substantial Completion

§ 3.3.1 Subject to adjustments of the Contract Time as provided in the Contract Documents, the Contractor shall achieve Substantial Completion of the entire Work:
(Check one of the following boxes and complete the necessary information.)

[] Not later than () calendar days from the date of commencement of the Work.

[] By the following date:

TIME IS OF THE ESSENCE WITH REGARD TO THE TIMELY PERFORMANCE OF THE AGREEMENT, ACHIEVEMENT OF ALL MILESTONES, SUBSTANTIAL COMPLETION AND FINAL COMPLETION OF THE PROJECT BY THE CONTRACTOR. If, in the sole opinion of the Owner, the Contractor is not adhering to the Project schedule and/or is not supplying sufficient labor and/or equipment to complete the Work by the Substantial Completion date contained herein, upon forty-eight (48) hours written notice, the Town shall have the right to direct the Contractor to increase its labor and/or equipment to meet established project schedules without additional compensation provided the Town is not responsible or in any way liable for the Contractor not adhering to the Project schedule. Any and all such additional labor or supervision shall be at Contractor's sole cost and expense and may include, but shall not be limited to, Town directing the Contractor to increase the workers on its crews, supply additional equipment, work overtime, work a second shift during a single day, work weekends, or any combination thereof, without any additional compensation being due to Contractor for such additional personnel. Any costs incurred or arising due to the Contractor's failure to achieve timely Substantial Completion shall be borne solely by the Contractor.

§ 3.3.1.1 Contractor expressly agrees, notwithstanding any provision in this Agreement to the contrary, that: (i) a COVID-19 pandemic exists worldwide as of the execution date of this Agreement; (ii) the existence of such pandemic, and its effects, now, and for the duration of Contractor's performance under the Agreement, shall not in and of itself be cause for Contractor to rely upon, invoke, or avail itself to, any rights or remedies under this Agreement, at law, or in equity, for a claim, or an adjustment to the price, schedule, quantities, specifications, or other material terms of this Agreement; (iii) the material terms of this Agreement, particularly terms relating to price, schedule, quantities, availability and specifications, take into consideration, and fully account for, the existence of such pandemic and its effects, as of the date of this Agreement; and (iv) such pandemic shall not render Contractor unable to fulfill any of its obligations under the Agreement, and Contractor shall not have any claim, action, or cause of action against the Owner in connection with such pandemic, including any claim for frustration of purpose change in circumstances, economic balance, or impossibility. This provision shall survive the completion or earlier termination of this Agreement.

§ 3.3.2 Subject to adjustments of the Contract Time as provided in the Contract Documents, if portions of the Work are to be completed prior to Substantial Completion of the entire Work, the Contractor shall achieve Substantial Completion of such portions by the following dates:

Portion of Work	Substantial Completion Date
<input type="text"/>	<input type="text"/>

§ 3.3.3 If the Contractor fails to achieve Substantial Completion as provided in this Section 3.3, liquidated damages, if any, shall be assessed as set forth in Section 4.5.

ARTICLE 4 CONTRACT SUM

§ 4.1 The Owner shall pay the Contractor the Contract Sum in current funds for the Contractor's performance of the Contract. The Contract Sum shall be (\$), subject to additions and deductions as provided in the Contract Documents.

§ 4.2 Alternates

§ 4.2.1 Alternates, if any, included in the Contract Sum:

Item	Price
<input type="text"/>	<input type="text"/>

§ 4.2.2 Subject to the conditions noted below, the following alternates may be accepted by the Owner following execution of this Agreement. Upon acceptance, the Owner shall issue a Modification to this Agreement. (Insert below each alternate and the conditions that must be met for the Owner to accept the alternate.)

Item	Price	Conditions for Acceptance
« »		

§ 4.3 Allowances, if any, included in the Contract Sum: (Identify each allowance.)

Item	Price
« »	

§ 4.4 Unit prices, if any: (Identify the item and state the unit price and quantity limitations, if any, to which the unit price will be applicable.)

Item	Units and Limitations	Price per Unit (\$0.00)
« »		

§ 4.5 Liquidated damages, if any: (Insert terms and conditions for liquidated damages, if any.)

«See A201 as modified. »

§ 4.6 Other: (Insert provisions for bonus or other incentives, if any, that might result in a change to the Contract Sum.)

« »

ARTICLE 5 PAYMENTS

§ 5.1 Progress Payments

§ 5.1.1 Based upon Applications for Payment submitted to the Architect by the Contractor and Certificates for Payment issued by the Architect, the Owner shall make progress payments on account of the Contract Sum to the Contractor as provided below and elsewhere in the Contract Documents.

§ 5.1.2 The period covered by each Application for Payment shall be one calendar month ending on the last day of the month, or as follows:

« »

§ 5.1.3 Provided that an Application for Payment is received by the Architect not later than the «25th » day of a month, the Owner shall make payment of the amount certified to the Contractor not later than thirty (30) days after the Owner approves the Application for Payment. If an Application for Payment is received by the Architect after the application date fixed above, payment of the amount certified shall be made by the Owner not later than «thirty » («30 ») days after the approves the Application for Payment certified by the Architect. (Federal, state or local laws may require payment within a certain period of time.)

§ 5.1.4 Each Application for Payment shall be based on the most recent schedule of values submitted by the Contractor in accordance with the Contract Documents. The schedule of values shall allocate the entire Contract Sum among the various portions of the Work. The schedule of values shall be prepared in such form, and supported by such data to substantiate its accuracy, as the Architect may require. This schedule of values shall be used as a basis for reviewing the Contractor's Applications for Payment.

§ 5.1.5 Applications for Payment shall show the percentage of completion of each portion of the Work as of the end of the period covered by the Application for Payment.

§ 5.1.6 In accordance with AIA Document A201™–2017, General Conditions of the Contract for Construction, and subject to other provisions of the Contract Documents, the amount of each progress payment shall be computed as follows:

§ 5.1.6.1 The amount of each progress payment shall first include:

- .1 That portion of the Contract Sum properly allocable to completed Work;
- .2 That portion of the Contract Sum properly allocable to materials and equipment delivered and suitably stored at the site for subsequent incorporation in the completed construction, or, if approved in advance by the Owner, suitably stored off the site at a location agreed upon in writing; and
- .3 That portion of Construction Change Directives that the Architect determines, in the Architect's professional judgment, to be reasonably justified.

§ 5.1.6.2 The amount of each progress payment shall then be reduced by:

- .1 The aggregate of any amounts previously paid by the Owner;
- .2 The amount, if any, for Work that remains uncorrected and for which the Architect has previously withheld a Certificate for Payment as provided in Article 9 of AIA Document A201–2017;
- .3 Any amount for which the Contractor does not intend to pay a Subcontractor or material supplier, unless the Work has been performed by others the Contractor intends to pay;
- .4 For Work performed or defects discovered since the last payment application, any amount for which the Architect may withhold payment, or nullify a Certificate of Payment in whole or in part, as provided in Article 9 of AIA Document A201–2017; and
- .5 Retainage withheld pursuant to Section 5.1.7.

§ 5.1.7 Retainage

§ 5.1.7.1 For each progress payment made prior to Substantial Completion of the Work, the Owner may withhold the following amount, as retainage, from the payment otherwise due:

(Insert a percentage or amount to be withheld as retainage from each Application for Payment. The amount of retainage may be limited by governing law.)

« Five percent (5%) »

§ 5.1.7.1.1 The following items are not subject to retainage:

(Insert any items not subject to the withholding of retainage, such as general conditions, insurance, etc.)

«N/A »

§ 5.1.7.2 Reduction or limitation of retainage, if any, shall be as follows:

(If the retainage established in Section 5.1.7.1 is to be modified prior to Substantial Completion of the entire Work, including modifications for Substantial Completion of portions of the Work as provided in Section 3.3.2, insert provisions for such modifications.)

«At the Owner's sole discretion. »

§ 5.1.7.3 Except as set forth in this Section 5.1.7.3, upon Substantial Completion of the Work, the Contractor may submit an Application for Payment that includes the retainage withheld from prior Applications for Payment pursuant to this Section 5.1.7. The Application for Payment submitted at Substantial Completion shall not include retainage as follows:

(Insert any other conditions for release of retainage upon Substantial Completion.)

Owner shall be entitled to retain two hundred percent (200%) of the estimated cost to complete punchlist items to reach Final Completion.

« »

§ 5.1.8 If final completion of the Work is materially delayed through no fault of the Contractor, the Owner shall pay the Contractor any additional amounts in accordance with Article 9 of AIA Document A201–2017.

§ 5.1.9 Except with the Owner's prior approval, the Contractor shall not make advance payments to suppliers for materials or equipment which have not been delivered and stored at the site.

§ 5.2 Final Payment

§ 5.2.1 Final payment, constituting the entire unpaid balance of the Contract Sum, shall be made by the Owner to the Contractor when

- .1 the Contractor has fully performed the Contract except for the Contractor's responsibility to correct Work as provided in Article 12 of AIA Document A201–2017, and to satisfy other requirements, if any, which extend beyond final payment; and
- .2 a final Certificate for Payment has been issued by the Architect.

§ 5.2.2 The Owner's final payment to the Contractor shall be made no later than 30 days after the issuance of the Architect's final Certificate for Payment, or as follows:

<< >>

§ 5.3 Intentionally Deleted.

ARTICLE 6 DISPUTE RESOLUTION

§ 6.1 Initial Decision Maker

The Architect will serve as the Initial Decision Maker pursuant to Article 15 of AIA Document A201–2017, unless the parties appoint below another individual, not a party to this Agreement, to serve as the Initial Decision Maker. *(If the parties mutually agree, insert the name, address and other contact information of the Initial Decision Maker, if other than the Architect.)*

<< >>

<< >>

<< >>

<< >>

§ 6.2 Binding Dispute Resolution

For any Claim subject to, but not resolved by, mediation pursuant to Article 15 of AIA Document A201–2017, the method of binding dispute resolution shall be as follows:

(Check the appropriate box.)

[] Arbitration pursuant to Section 15.4 of AIA Document A201–2017

[] Litigation in a court of competent jurisdiction

[] Other *(Specify)*

«Litigation in Connecticut Superior Court in and for the Judicial District of New Haven unless the Owner, in its sole discretion, elects to arbitrate a dispute..»

If the Owner and Contractor do not select a method of binding dispute resolution, or do not subsequently agree in writing to a binding dispute resolution method other than litigation, Claims will be resolved by litigation in a court of competent jurisdiction.

ARTICLE 7 TERMINATION OR SUSPENSION

§ 7.1 The Contract may be terminated by the Owner or the Contractor as provided in Article 14 of AIA Document A201–2017.

§ 7.1.1 Intentionally Deleted.

<< >>

§ 7.2 The Work may be suspended by the Owner as provided in Article 14 of AIA Document A201–2017.

ARTICLE 8 MISCELLANEOUS PROVISIONS

§ 8.1 Where reference is made in this Agreement to a provision of AIA Document A201–2017 or another Contract Document, the reference refers to that provision as amended or supplemented by other provisions of the Contract Documents.

§ 8.2 The Owner’s representative:
(Name, address, email address, and other information)

«To be named by the Owner in writing within ten (10) days of the execution of this Agreement. »
« »
« »
« »
« »
« »

§ 8.3 The Contractor’s representative:
(Name, address, email address, and other information)

« To be named by the Contractor in writing within ten (10) days of the execution of this Agreement »
« »
« »
« »
« »
« »

§ 8.4 Neither the Owner’s nor the Contractor’s representative shall be changed without ten days’ prior notice to the other party.

§ 8.5 Insurance and Bonds

§ 8.5.1 The Owner and the Contractor shall purchase and maintain insurance as set forth in AIA Document A101™–2017, Standard Form of Agreement Between Owner and Contractor where the basis of payment is a Stipulated Sum, Exhibit A, Insurance and Bonds, and elsewhere in the Contract Documents.

§ 8.5.2 The Contractor shall provide bonds as set forth in AIA Document A101™–2017 Exhibit A, and elsewhere in the Contract Documents.

§ 8.6 Notice in electronic format, pursuant to Article 1 of AIA Document A201–2017, may be given in accordance with AIA Document E203™–2013, Building Information Modeling and Digital Data Exhibit, if completed, or as otherwise set forth below:

(If other than in accordance with AIA Document E203–2013, insert requirements for delivering notice in electronic format such as name, title, and email address of the recipient and whether and how the system will be required to generate a read receipt for the transmission.)

« »

§ 8.7 Other provisions:

« »

ARTICLE 9 ENUMERATION OF CONTRACT DOCUMENTS

§ 9.1 This Agreement is comprised of the following documents:

- .1 AIA Document A101™–2017, Standard Form of Agreement Between Owner and Contractor
- .2 AIA Document A101™–2017, Exhibit A, Insurance and Bonds
- .3 AIA Document A201™–2017, General Conditions of the Contract for Construction, as modified
- .4 AIA Document E203™–2013, Building Information Modeling and Digital Data Exhibit, dated as indicated below:

(Insert the date of the E203-2013 incorporated into this Agreement.)



.5 Drawings

Number	Title	Date
«	COVER	August 09, 2021
A1	Bathroom Plans, Sections and Elevations	
A2	Handicap Signs and Accessories	
P1	Quinnipiac Park Plumbing Demolition And Proposed Plumbing Plans	
P2	Plumbing Schedules, Details, Symbols, Notes and Abbreviations	
ME1	Quinnipiac Park Mechanical/Electrical Demolition and Proposed Plans	
ME2	Electrical Schedules, Details, Symbols, Notes and abbreviations	

.6 Specifications

Section	Title	Date	Pages
Section 01010	Special Conditions	August 09, 2021	
Section 01040	Project Coordination		
Section 01300	Submittals and Product Substitutions		
Section 01400	Quality Control Services		
Section 01500	Temporary Facilities		
Section 01600	Reference Standards, Definitions, Materials and Equipment		
Section 01700	Project Closeout		
Section 01710	Cleaning of New Spaces		

.7 Addenda, if any:

Number	Date	Pages
« »		

Portions of Addenda relating to bidding or proposal requirements are not part of the Contract Documents unless the bidding or proposal requirements are also enumerated in this Article 9.

.8 Other Exhibits:

(Check all boxes that apply and include appropriate information identifying the exhibit where required.)

[« »] AIA Document E204™-2017, Sustainable Projects Exhibit, dated as indicated below: (Insert the date of the E204-2017 incorporated into this Agreement.)



[« »] The Sustainability Plan:

Title	Date	Pages
<< >>		

[<< >>] Supplementary and other Conditions of the Contract:

Document	Title	Date	Pages
<< >>			

9 Other documents, if any, listed below:

(List here any additional documents that are intended to form part of the Contract Documents. AIA Document A201™–2017 provides that the advertisement or invitation to bid, Instructions to Bidders, sample forms, the Contractor’s bid or proposal, portions of Addenda relating to bidding or proposal requirements, and other information furnished by the Owner in anticipation of receiving bids or proposals, are not part of the Contract Documents unless enumerated in this Agreement. Any such documents should be listed here only if intended to be part of the Contract Documents.)

<<< Town of Cheshire, Invitation to Bid
 Instructions to Bidders, AIA A701, and Supplemental Instructions to Bidders
 State of CT, Prevailing Wage Rates
 Contractor’s Bid Proposal
 >>>

This Agreement entered into as of the day and year first written above.

<< >>

 OWNER (Signature)
 << >><> >>

 (Printed name and title)

<< >>

 CONTRACTOR (Signature)
 << >><> >>

 (Printed name and title)

DRAFT AIA® Document A101™ - 2017

Exhibit A

Insurance and Bonds

This Insurance and Bonds Exhibit is part of the Agreement, between the Owner and the Contractor, dated the « » day of « » in the year « »
(In words, indicate day, month and year.)

for the following PROJECT:
(Name and location or address)

Renovation to Existing Bathroom at Quinnipiac Park 2122-10
1325 Cheshire St, Cheshire, CT 06410 »
« »

THE OWNER:
(Name, legal status and address)

« « Town of Cheshire
»84 South Main Street
Cheshire, CT 06410 »
« »
»« »
« »

THE CONTRACTOR:
(Name, legal status and address)

« »« »
« »

TABLE OF ARTICLES

- A.1 GENERAL
- A.2 OWNER'S INSURANCE
- A.3 CONTRACTOR'S INSURANCE AND BONDS
- A.4 SPECIAL TERMS AND CONDITIONS

ARTICLE A.1 GENERAL

The Owner and Contractor shall purchase and maintain insurance, and provide bonds, from companies that are acceptable to the Owner and that are lawfully authorized to do business in Connecticut, as set forth in this Exhibit. As used in this Exhibit, the term General Conditions refers to AIA Document A201™-2017, General Conditions of the Contract for Construction, as modified.

ARTICLE A.2 OWNER'S INSURANCE

§ A.2.1 General

Prior to commencement of the Work, the Owner shall secure the insurance, and provide evidence of the coverage, required under this Article A.2 and, upon the Contractor's

ADDITIONS AND DELETIONS:
The author of this document has added information needed for its completion. The author may also have revised the text of the original AIA standard form. An *Additions and Deletions Report* that notes added information as well as revisions to the standard form text is available from the author and should be reviewed.

This document has important legal consequences. Consultation with an attorney is encouraged with respect to its completion or modification.

This document is intended to be used in conjunction with AIA Document A201™-2017, General Conditions of the Contract for Construction. Article 11 of A201™-2017 contains additional insurance provisions.

ELECTRONIC COPYING of any portion of this AIA® Document to another electronic file is prohibited and constitutes a violation of copyright laws as set forth in the footer of this document.

request, provide a copy of the property insurance policy or policies required by Section A.2.3. The copy of the policy or policies provided shall contain all applicable conditions, definitions, exclusions, and endorsements.

§ A.2.2 Liability Insurance

The Owner shall be responsible for purchasing and maintaining the Owner’s usual general liability insurance.

§ A.2.3 Required Property Insurance

§ A.2.3.1 Unless this obligation is placed on the Contractor pursuant to Section A.3.3.2.1, the Owner shall purchase and maintain, from an insurance company or insurance companies lawfully authorized to issue insurance in the jurisdiction where the Project is located, property insurance written on a builder’s risk “all-risks” completed value or equivalent policy form and sufficient to cover the total value of the entire Project on a replacement cost basis. The Owner’s property insurance coverage shall be no less than the amount of the initial Contract Sum, plus the value of subsequent Modifications and labor performed and materials or equipment supplied by others. The property insurance shall be maintained until Substantial Completion and thereafter as provided in Section A.2.3.1.3, unless otherwise provided in the Contract Documents or otherwise agreed in writing by the parties to this Agreement. This insurance shall include the interests of the Owner, Contractor, Subcontractors, and Sub-subcontractors in the Project as insureds. This insurance shall include the interests of mortgagees as loss payees.

Commented [MJD1]: The Town needs to determine whether it will procure Builder’s Risk Insurance, or whether it wishes to put that obligation onto the Contractor.

§ A.2.3.1.1 Causes of Loss. The insurance required by this Section A.2.3.1 shall provide coverage for direct physical loss or damage, and shall not exclude the risks of fire, explosion, theft, vandalism, malicious mischief, collapse, earthquake, flood, or windstorm. The insurance shall also provide coverage for ensuing loss or resulting damage from error, omission, or deficiency in construction methods, design, specifications, workmanship, or materials. Sub-limits, if any, are as follows:

(Indicate below the cause of loss and any applicable sub-limit.)

Causes of Loss	Sub-Limit
« »	

§ A.2.3.1.2 Specific Required Coverages. The insurance required by this Section A.2.3.1 shall provide coverage for loss or damage to falsework and other temporary structures, and to building systems from testing and startup. The insurance shall also cover debris removal, including demolition occasioned by enforcement of any applicable legal requirements, and reasonable compensation for the Architect’s and Contractor’s services and expenses required as a result of such insured loss, including claim preparation expenses. Sub-limits, if any, are as follows:

(Indicate below type of coverage and any applicable sub-limit for specific required coverages.)

Coverage	Sub-Limit
« »	

§ A.2.3.1.3 Unless the parties agree otherwise, upon Substantial Completion, the Owner shall continue the insurance required by Section A.2.3.1 or, if necessary, replace the insurance policy required under Section A.2.3.1 with property insurance written for the total value of the Project that shall remain in effect until expiration of the period for correction of the Work set forth in Section 12.2.2 of the General Conditions.

§ A.2.3.1.4 Deductibles and Self-Insured Retentions. If the insurance required by this Section A.2.3 is subject to deductibles or self-insured retentions, the Owner shall be responsible for all loss not covered because of such deductibles or retentions.

Commented [MJD2]: Change to Contractor, if Contractor is purchasing the insurance.

§ A.2.3.2 Occupancy or Use Prior to Substantial Completion. The Owner’s occupancy or use of any completed or partially completed portion of the Work prior to Substantial Completion shall not commence until the insurance company or companies providing the insurance under Section A.2.3.1 have consented in writing to the continuance of coverage. The Owner and the Contractor shall take no action with respect to partial occupancy or use that would cause cancellation, lapse, or reduction of insurance, unless they agree otherwise in writing.

§ A.2.3.3 Insurance for Existing Structures

If the Work involves remodeling an existing structure or constructing an addition to an existing structure, the Owner shall purchase and maintain, until the expiration of the period for correction of Work as set forth in Section 12.2.2 of the General Conditions, “all-risks” property insurance, on a replacement cost basis, protecting the existing structure

against direct physical loss or damage from the causes of loss identified in Section A.2.3.1, notwithstanding the undertaking of the Work. The Owner shall be responsible for all co-insurance penalties.

§ A.2.4 Optional Extended Property Insurance.

The Owner shall purchase and maintain the insurance selected and described below.

(Select the types of insurance the Owner is required to purchase and maintain by placing an X in the box(es) next to the description(s) of selected insurance. For each type of insurance selected, indicate applicable limits of coverage or other conditions in the fill point below the selected item.)

- § A.2.4.1 Loss of Use, Business Interruption, and Delay in Completion Insurance, to reimburse the Owner for loss of use of the Owner's property, or the inability to conduct normal operations due to a covered cause of loss.
- § A.2.4.2 Ordinance or Law Insurance, for the reasonable and necessary costs to satisfy the minimum requirements of the enforcement of any law or ordinance regulating the demolition, construction, repair, replacement or use of the Project.
- § A.2.4.3 Expediting Cost Insurance, for the reasonable and necessary costs for the temporary repair of damage to insured property, and to expedite the permanent repair or replacement of the damaged property.
- § A.2.4.4 Extra Expense Insurance, to provide reimbursement of the reasonable and necessary excess costs incurred during the period of restoration or repair of the damaged property that are over and above the total costs that would normally have been incurred during the same period of time had no loss or damage occurred.
- § A.2.4.5 Civil Authority Insurance, for losses or costs arising from an order of a civil authority prohibiting access to the Project, provided such order is the direct result of physical damage covered under the required property insurance.
- § A.2.4.6 Ingress/Egress Insurance, for loss due to the necessary interruption of the insured's business due to physical prevention of ingress to, or egress from, the Project as a direct result of physical damage.
- § A.2.4.7 Soft Costs Insurance, to reimburse the Owner for costs due to the delay of completion of the Work, arising out of physical loss or damage covered by the required property insurance: including construction loan fees; leasing and marketing expenses; additional fees, including those of architects, engineers, consultants, attorneys and accountants, needed for the completion of the construction, repairs, or reconstruction; and carrying costs such as property taxes, building permits, additional interest on loans, realty taxes, and insurance premiums over and above normal expenses.

§ A.2.5 Other Optional Insurance.

The Owner shall purchase and maintain the insurance selected below.

(Select the types of insurance the Owner is required to purchase and maintain by placing an X in the box(es) next to

the description(s) of selected insurance.)

[« »] § A.2.5.1 Cyber Security Insurance for loss to the Owner due to data security and privacy breach, including costs of investigating a potential or actual breach of confidential or private information. (Indicate applicable limits of coverage or other conditions in the fill point below.)

« »

[« »] § A.2.5.2 Other Insurance (List below any other insurance coverage to be provided by the Owner and any applicable limits.)

Coverage	Limits
« »	

ARTICLE A.3 CONTRACTOR'S INSURANCE AND BONDS

§ A.3.1 General

§ A.3.1.1 Certificates of Insurance. The Contractor shall provide certificates of insurance acceptable to the Owner evidencing compliance with the requirements in this Article A.3 at the following times: (1) prior to commencement of the Work; (2) upon renewal or replacement of each required policy of insurance; and (3) upon the Owner's written request. An additional certificate evidencing continuation of commercial liability coverage, including coverage for completed operations, shall be submitted with the final Application for Payment and thereafter upon renewal or replacement of such coverage until the expiration of the periods required by Section A.3.2.1 and Section A.3.3.1. The certificates will show the Owner as an additional insured on the Contractor's Commercial General Liability and excess or umbrella liability policy or policies.

§ A.3.1.2 Deductibles and Self-Insured Retentions. The Contractor shall disclose to the Owner any deductible or self-insured retentions applicable to any insurance required to be provided by the Contractor.

§ A.3.1.3 Additional Insured Obligations. To the fullest extent permitted by law, the Contractor shall cause the commercial general liability, automobile liability and umbrella coverages to include (1) the Owner, the Architect, and the Architect's consultants as additional insureds for claims caused in whole or in part by the Contractor's negligent acts or omissions during the Contractor's operations; and (2) the Owner as an additional insured for claims caused in whole or in part by the Contractor's negligent acts or omissions for which loss occurs during completed operations. The additional insured coverage shall be primary and non-contributory to any of the Owner's general liability insurance policies and shall apply to both ongoing and completed operations. To the extent commercially available, the additional insured coverage shall be no less than that provided by Insurance Services Office, Inc. (ISO) forms CG 20 10 07 04, CG 20 37 07 04, and, with respect to the Architect and the Architect's consultants, CG 20 32 07 04.

§ A.3.2 Contractor's Required Insurance Coverage

§ A.3.2.1 The Contractor shall purchase and maintain the following types and limits of insurance from an insurance company or insurance companies which are lawfully authorized to issue insurance in Connecticut and are acceptable to the Owner. The Contractor shall maintain the required insurance without interruption from the date of commencement of the Work until the date of final payment and termination of any coverage required to be maintained after final payment, and with respect to Contractor's completed operations coverages, as specified in the Contract Documents.

If the Contractor fails to purchase and maintain any insurance required by the Contract Documents, the Owner may, but shall not be obligated to, upon two (2) days' written notice to the Contractor, purchase such insurance on behalf of the Contractor and shall be entitled to be reimbursed by the Contractor promptly upon demand or deduct the amount of such premiums from the Contract Sum. Alternatively, the Owner may order cessation of all construction activities until such time all insurance requirements have been complied with. Under such circumstances, the Contractor shall have no recourse against the Owner.

(If the Contractor is required to maintain insurance for a duration other than the expiration of the period for correction of Work, state the duration.)

AIA Document A101™ - 2017 Exhibit A. Copyright © 2017 by The American Institute of Architects. All rights reserved. WARNING: This AIA® Document is protected by U.S. Copyright Law and International Treaties. Unauthorized reproduction or distribution of this AIA® Document, or any portion of it, may result in severe civil and criminal penalties, and will be prosecuted to the maximum extent possible under the law. This draft was produced by AIA software at 09:05:35 on 06/19/2017 under Order No. 3496021312 which expires on 01/12/2018, and is not for resale.

User Notes:

(3B9ADA1B)

§ A.3.2.2 Commercial General Liability

§ A.3.2.2.1 Commercial General Liability insurance for the Project written on an occurrence form with policy limits of not less than «two million dollars» (\$ «2,000,000») each occurrence, «two million dollars» (\$ «2,000,000») general aggregate, and «two million dollars» (\$ «2,000,000») aggregate for products-completed operations hazard, providing coverage for claims including

- .1 damages because of bodily injury, sickness or disease, including occupational sickness or disease, and death of any person;
- .2 personal injury and advertising injury;
- .3 Premises-Operations and Independent Contractors Protective Products;
- .4 damages because of physical damage to or destruction of tangible property, including the loss of use of such property;
- .5 bodily injury or property damage arising out of completed operations (which shall be maintained for five (5) years after final payment; and
- .6 the Contractor's indemnity obligations under Section 3.18 of the General Conditions.

§ A.3.2.2.2 The Contractor's Commercial General Liability policy under this Section A.3.2.2 shall not contain an exclusion or restriction of coverage for the following:

- .1 Claims by one insured against another insured, if the exclusion or restriction is based solely on the fact that the claimant is an insured, and there would otherwise be coverage for the claim.
- .2 Claims for property damage to the Contractor's Work arising out of the products-completed operations hazard where the damaged Work or the Work out of which the damage arises was performed by a Subcontractor.
- .3 Claims for bodily injury other than to employees of the insured.
- .4 Claims for indemnity under Section 3.18 of the General Conditions arising out of injury to employees of the insured.
- .5 Claims or loss excluded under a prior work endorsement or other similar exclusionary language.
- .6 Claims or loss due to physical damage under a prior injury endorsement or similar exclusionary language.
- .7 Claims related to residential, multi-family, or other habitational projects, if the Work is to be performed on such a project.
- .8 Claims related to roofing, if the Work involves roofing.
- .9 Claims related to exterior insulation finish systems (EIFS), synthetic stucco or similar exterior coatings or surfaces, if the Work involves such coatings or surfaces.
- .10 Claims related to earth subsidence or movement, where the Work involves such hazards.
- .11 Claims related to explosion, collapse and underground hazards, where the Work involves such hazards.

§ A.3.2.3 Automobile Liability covering vehicles owned, non-owned and hired vehicles used, by the Contractor, with policy limits of not less than «one million dollars» (\$ «1,000,000») per accident, for bodily injury, death of any person, and property damage arising out of the ownership, maintenance and use of those motor vehicles along with any other statutorily required automobile coverage.

§ A.3.2.4 The Contractor may achieve the required limits and coverage for Commercial General Liability and Automobile Liability through a combination of primary and excess or umbrella liability insurance, provided such primary and excess or umbrella insurance policies result in the same or greater coverage as the coverages required under Section A.3.2.2 and A.3.2.3, and in no event shall any excess or umbrella liability insurance provide narrower coverage than the primary policy. The excess policy shall not require the exhaustion of the underlying limits only through the actual payment by the underlying insurers.

§ A.3.2.5 Workers' Compensation at statutory limits.

§ A.3.2.6 Employers' Liability with policy limits not less than «five hundred thousand dollars» (\$ «500,000») each accident, «five hundred thousand» (\$ «500,000») Disease, five hundred thousand (\$500,000) each employee, and «five hundred thousand» (\$ «500,000») policy limit.

§ A.3.2.7 Jones Act, and the Longshore & Harbor Workers' Compensation Act, as required, if the Work involves hazards arising from work on or near navigable waterways, including vessels and docks

§ A.3.2.8 If the Contractor is required to furnish professional services as part of the Work, the Contractor shall procure Professional Liability insurance covering performance of the professional services, with policy limits of not less than «one million dollars» (\$ «1,000,000») per claim and «one million dollars» (\$ «1,000,000») in the aggregate.

§ A.3.2.9 If the Work involves the transport, dissemination, use, or release of pollutants, the Contractor shall procure Pollution Liability insurance, with policy limits of not less than «one million dollars» (\$ «1,000,000») per claim and «one million dollars» (\$ «1,000,000») in the aggregate. The Owner shall be named as an additional insured on all such policies. Contractor shall deliver to the Owner certificate(s) evidencing such insurance prior to starting any remediation or transportation of hazardous materials.

The Contractor or any Subcontractor of any tier which remediates or transports hazardous materials must have the appropriate license(s) from the State and/or U.S. Government and must carry full pollution liability coverage. The Owner will be named as an additional insured on all such policies. Contractor will deliver to the Owner certificate(s) evidencing such insurance prior to starting any remediation or transportation of hazardous materials.

§ A.3.2.10 Coverage under Sections A.3.2.8 and A.3.2.9 may be procured through a Combined Professional Liability and Pollution Liability insurance policy, with combined policy limits of not less than «» (\$ «») per claim and «» (\$ «») in the aggregate.

§ A.3.2.11 Insurance for maritime liability risks associated with the operation of a vessel, if the Work requires such activities, with policy limits of not less than «» (\$ «») per claim and «» (\$ «») in the aggregate.

§ A.3.2.12 Insurance for the use or operation of manned or unmanned aircraft, if the Work requires such activities, with policy limits of not less than «» (\$ «») per claim and «» (\$ «») in the aggregate.

§ A.3.3 Contractor's Other Insurance Coverage

§ A.3.3.1 Insurance selected and described in this Section A.3.3 shall be purchased from an insurance company or insurance companies lawfully authorized to issue insurance in the jurisdiction where the Project is located. The Contractor shall maintain the required insurance until the expiration of the period for correction of Work as set forth in Section 12.2.2 of the General Conditions, unless a different duration is stated below:

(If the Contractor is required to maintain any of the types of insurance selected below for a duration other than the expiration of the period for correction of Work, state the duration.)

« »

§ A.3.3.2 The Contractor shall purchase and maintain the following types and limits of insurance in accordance with Section A.3.3.1.

(Select the types of insurance the Contractor is required to purchase and maintain by placing an X in the box(es) next to the description(s) of selected insurance. Where policy limits are provided, include the policy limit in the appropriate fill point.)

- [« »] § A.3.3.2.1 Property insurance of the same type and scope satisfying the requirements identified in Section A.2.3, which, if selected in this section A.3.3.2.1, relieves the Owner of the responsibility to purchase and maintain such insurance except insurance required by Section A.2.3.1.3 and Section A.2.3.3. The Contractor shall comply with all obligations of the Owner under Section A.2.3 except to the extent provided below. The Contractor shall disclose to the Owner the amount of any deductible, and the Owner shall be responsible for losses within the deductible. Upon request, the Contractor shall provide the Owner with a copy of the property insurance policy or policies required. The Owner shall adjust and settle the loss with the insurer and be the trustee of the proceeds of the property insurance in accordance with Article 11 of the General Conditions unless otherwise set forth below:
*(Where the Contractor's obligation to provide property insurance differs from the Owner's obligations as described under Section A.2.3, indicate such differences in the space below.
Additionally, if a party other than the Owner will be responsible for adjusting and settling a loss with*

AIA Document A101™ - 2017 Exhibit A. Copyright © 2017 by The American Institute of Architects. All rights reserved. WARNING: This AIA® Document is protected by U.S. Copyright Law and International Treaties. Unauthorized reproduction or distribution of this AIA® Document, or any portion of it, may result in severe civil and criminal penalties, and will be prosecuted to the maximum extent possible under the law. This draft was produced by AIA software at 09:05:35 on 06/19/2017 under Order No. 3496021312 which expires on 01/12/2018, and is not for resale.

User Notes:

(3B9ADA1B)

the insurer and acting as the trustee of the proceeds of property insurance in accordance with Article 11 of the General Conditions, indicate the responsible party below.)

« »

- [« »] § A.3.3.2.2 Railroad Protective Liability Insurance, with policy limits of not less than « » (\$ « ») per claim and « » (\$ « ») in the aggregate, for Work within fifty (50) feet of railroad property.
- [« »] § A.3.3.2.3 Asbestos Abatement Liability Insurance, with policy limits of not less than « » (\$ « ») per claim and « » (\$ « ») in the aggregate, for liability arising from the encapsulation, removal, handling, storage, transportation, and disposal of asbestos-containing materials.
- [« »] § A.3.3.2.4 Insurance for physical damage to property while it is in storage and in transit to the construction site on an "all-risks" completed value form.
- [« »] § A.3.3.2.5 Property insurance on an "all-risks" completed value form, covering property owned by the Contractor and used on the Project, including scaffolding and other equipment.
- [« »] § A.3.3.2.6 Other Insurance
(List below any other insurance coverage to be provided by the Contractor and any applicable limits.)

Coverage	Limits
<u>Umbrella Excess Liability</u>	\$10,000,000 Over primary insurance
»	\$10,000 Retention

§ A.3.4 Performance Bond and Payment Bond

The Contractor shall provide surety bonds, from a company or companies lawfully authorized to issue surety bonds in the jurisdiction where the Project is located and which are acceptable to the Owner, in an amount equal to the Contract Sum and all subsequent increases.

Payment and Performance Bonds shall be AIA Document A312™, Payment Bond and Performance Bond, or contain provisions identical to AIA Document A312™, current as of the date of this Agreement, or as acceptable to the Owner.

ARTICLE A.4 SPECIAL TERMS AND CONDITIONS

Special terms and conditions that modify this Insurance and Bonds Exhibit, if any, are as follows:

« »

DRAFT AIA® Document A201™ - 2017

General Conditions of the Contract for Construction

for the following PROJECT:

(Name and location or address)

«
Renovation to Existing Bathroom at Quinnipiac Park 2122-04
1325 Cheshire St, Cheshire, CT 06410»
« »

THE OWNER:

(Name, legal status and address)

«Town of Cheshire
84 South Main Street
Cheshire, CT 06410« »
« »

THE ARCHITECT:

(Name, legal status and address)

« WOJAS.ARCH, LLC
5Race Track Hollow
Middlefield, CT 06455 »« »
« »

TABLE OF ARTICLES

- 1 GENERAL PROVISIONS
- 2 OWNER
- 3 CONTRACTOR
- 4 ARCHITECT
- 5 SUBCONTRACTORS
- 6 CONSTRUCTION BY OWNER OR BY SEPARATE CONTRACTORS
- 7 CHANGES IN THE WORK
- 8 TIME
- 9 PAYMENTS AND COMPLETION
- 10 PROTECTION OF PERSONS AND PROPERTY
- 11 INSURANCE AND BONDS
- 12 UNCOVERING AND CORRECTION OF WORK

ADDITIONS AND DELETIONS:

The author of this document has added information needed for its completion. The author may also have revised the text of the original AIA standard form. An *Additions and Deletions Report* that notes added information as well as revisions to the standard form text is available from the author and should be reviewed.

This document has important legal consequences. Consultation with an attorney is encouraged with respect to its completion or modification.

For guidance in modifying this document to include supplementary conditions, see AIA Document A503™, Guide for Supplementary Conditions.

ELECTRONIC COPYING of any portion of this AIA® Document to another electronic file is prohibited and constitutes a violation of copyright laws as set forth in the footer of this document.

- 13 MISCELLANEOUS PROVISIONS
- 14 TERMINATION OR SUSPENSION OF THE CONTRACT
- 15 CLAIMS AND DISPUTES



INDEX

(Topics and numbers in bold are Section headings.)

Acceptance of Nonconforming Work

9.6.6, 9.9.3, **12.3**

Acceptance of Work

9.6.6, 9.8.2, 9.9.3, 9.10.1, 9.10.3, 12.3

Access to Work

3.16, 6.2.1, 12.1

Accident Prevention

10

Acts and Omissions

3.2, 3.3.2, 3.12.8, 3.18, 4.2.3, 8.3.1, 9.5.1, 10.2.5,
10.2.8, 13.3.2, 14.1, 15.1.2, 15.2

Addenda

1.1.1

Additional Costs, Claims for

3.7.4, 3.7.5, 10.3.2, 15.1.5

Additional Inspections and Testing

9.4.2, 9.8.3, 12.2.1, **13.4**

Additional Time, Claims for

3.2.4, 3.7.4, 3.7.5, 3.10.2, 8.3.2, **15.1.6**

Administration of the Contract

3.1.3, **4.2**, 9.4, 9.5

Advertisement or Invitation to Bid

1.1.1

Aesthetic Effect

4.2.13

Allowances

3.8

Applications for Payment

4.2.5, 7.3.9, 9.2, **9.3**, 9.4, 9.5.1, 9.5.4, 9.6.3, 9.7, 9.10

Approvals

2.1.1, 2.3.1, 2.5, 3.1.3, 3.10.2, 3.12.8, 3.12.9,

3.12.10.1, 4.2.7, 9.3.2, 13.4.1

Arbitration

8.3.1, 15.3.2, **15.4**

ARCHITECT

4

Architect, Definition of

4.1.1

Architect, Extent of Authority

2.5, 3.12.7, 4.1.2, 4.2, 5.2, 6.3, 7.1.2, 7.3.4, 7.4, 9.2,
9.3.1, 9.4, 9.5, 9.6.3, 9.8, 9.10.1, 9.10.3, 12.1, 12.2.1,
13.4.1, 13.4.2, 14.2.2, 14.2.4, 15.1.4, 15.2.1

Architect, Limitations of Authority and
Responsibility

2.1.1, 3.12.4, 3.12.8, 3.12.10, 4.1.2, 4.2.1, 4.2.2,
4.2.3, 4.2.6, 4.2.7, 4.2.10, 4.2.12, 4.2.13, 5.2.1, 7.4,
9.4.2, 9.5.4, 9.6.4, 15.1.4, 15.2

Architect's Additional Services and Expenses

2.5, 12.2.1, 13.4.2, 13.4.3, 14.2.4

Architect's Administration of the Contract

3.1.3, 3.7.4, 15.2, 9.4.1, 9.5

Architect's Approvals

2.5, 3.1.3, 3.5, 3.10.2, 4.2.7

Architect's Authority to Reject Work

3.5, 4.2.6, 12.1.2, 12.2.1

Architect's Copyright

1.1.7, 1.5

Architect's Decisions

3.7.4, 4.2.6, 4.2.7, 4.2.11, 4.2.12, 4.2.13, 4.2.14, 6.3,
7.3.4, 7.3.9, 8.1.3, 8.3.1, 9.2, 9.4.1, 9.5, 9.8.4, 9.9.1,
13.4.2, 15.2

Architect's Inspections

3.7.4, 4.2.2, 4.2.9, 9.4.2, 9.8.3, 9.9.2, 9.10.1, 13.4

Architect's Instructions

3.2.4, 3.3.1, 4.2.6, 4.2.7, 13.4.2

Architect's Interpretations

4.2.11, 4.2.12

Architect's Project Representative

4.2.10

Architect's Relationship with Contractor

1.1.2, 1.5, 2.3.3, 3.1.3, 3.2.2, 3.2.3, 3.2.4, 3.3.1, 3.4.2,
3.5, 3.7.4, 3.7.5, 3.9.2, 3.9.3, 3.10, 3.11, 3.12, 3.16,
3.18, 4.1.2, 4.2, 5.2, 6.2.2, 7, 8.3.1, 9.2, 9.3, 9.4, 9.5,
9.7, 9.8, 9.9, 10.2.6, 10.3, 11.3, 12, 13.3.2, 13.4, 15.2

Architect's Relationship with Subcontractors

1.1.2, 4.2.3, 4.2.4, 4.2.6, 9.6.3, 9.6.4, 11.3

Architect's Representations

9.4.2, 9.5.1, 9.10.1

Architect's Site Visits

3.7.4, 4.2.2, 4.2.9, 9.4.2, 9.5.1, 9.9.2, 9.10.1, 13.4

Asbestos

10.3.1

Attorneys' Fees

3.18.1, 9.6.8, 9.10.2, 10.3.3

Award of Separate Contracts

6.1.1, 6.1.2

Award of Subcontracts and Other Contracts for Portions of the Work

5.2

Basic Definitions

1.1

Bidding Requirements

1.1.1

Binding Dispute Resolution

8.3.1, 9.7, 11.5, 13.1, 15.1.2, 15.1.3, 15.2.1, 15.2.5,
15.2.6.1, 15.3.1, 15.3.2, 15.3.3, 15.4.1

Bonds, Lien

7.3.4.4, 9.6.8, 9.10.2, 9.10.3

Bonds, Performance, and Payment

7.3.4.4, 9.6.7, 9.10.3, **11.1.2**, 11.1.3, **11.5**

Building Information Models Use and Reliance

1.8

Building Permit

3.7.1

Capitalization

1.3

Certificate of Substantial Completion

9.8.3, 9.8.4, 9.8.5

Certificates for Payment

4.2.1, 4.2.5, 4.2.9, 9.3.3, **9.4**, 9.5, 9.6.1, 9.6.6, 9.7, 9.10.1, 9.10.3, 14.1.1.3, 14.2.4, 15.1.4
Certificates of Inspection, Testing or Approval
13.4.4
Certificates of Insurance
9.10.2
Change Orders
1.1.1, 3.4.2, 3.7.4, 3.8.2.3, 3.11, 3.12.8, 4.2.8, 5.2.3, 7.1.2, 7.1.3, **7.2**, 7.3.2, 7.3.7, 7.3.9, 7.3.10, 8.3.1, 9.3.1.1, 9.10.3, 10.3.2, 11.2, 11.5, 12.1.2
Change Orders, Definition of
7.2.1
CHANGES IN THE WORK
2.2.2, 3.11, 4.2.8, **7**, 7.2.1, 7.3.1, 7.4, 8.3.1, 9.3.1.1, 11.5
Claims, Definition of
15.1.1
Claims, Notice of
1.6.2, 15.1.3
CLAIMS AND DISPUTES
3.2.4, 6.1.1, 6.3, 7.3.9, 9.3.3, 9.10.4, 10.3.3, **15**, 15.4
Claims and Timely Assertion of Claims
15.4.1
Claims for Additional Cost
3.2.4, 3.3.1, 3.7.4, 7.3.9, 9.5.2, 10.2.5, 10.3.2, **15.1.5**
Claims for Additional Time
3.2.4, 3.3.1, 3.7.4, 6.1.1, 8.3.2, 9.5.2, 10.3.2, **15.1.6**
Concealed or Unknown Conditions, Claims for
3.7.4
Claims for Damages
3.2.4, 3.18, 8.3.3, 9.5.1, 9.6.7, 10.2.5, 10.3.3, 11.3, 11.3.2, 14.2.4, 15.1.7
Claims Subject to Arbitration
15.4.1
Cleaning Up
3.15, 6.3
Commencement of the Work, Conditions Relating to
2.2.1, 3.2.2, 3.4.1, 3.7.1, 3.10.1, 3.12.6, 5.2.1, 5.2.3, 6.2.2, 8.1.2, 8.2.2, 8.3.1, 11.1, 11.2, **15.1.5**
Commencement of the Work, Definition of
8.1.2
Communications
3.9.1, **4.2.4**
Completion, Conditions Relating to
3.4.1, 3.11, 3.15, 4.2.2, 4.2.9, 8.2, 9.4.2, 9.8, 9.9.1, 9.10, 12.2, 14.1.2, 15.1.2
COMPLETION, PAYMENTS AND
9
Completion, Substantial
3.10.1, 4.2.9, 8.1.1, 8.1.3, 8.2.3, 9.4.2, 9.8, 9.9.1, 9.10.3, 12.2, 15.1.2
Compliance with Laws
2.3.2, 3.2.3, 3.6, 3.7, 3.12.10, 3.13, 9.6.4, 10.2.2, 13.1, 13.3, 13.4.1, 13.4.2, 13.5, 14.1.1, 14.2.1.3, 15.2.8, 15.4.2, 15.4.3
Concealed or Unknown Conditions
3.7.4, 4.2.8, 8.3.1, 10.3

Conditions of the Contract
1.1.1, 6.1.1, 6.1.4
Consent, Written
3.4.2, 3.14.2, 4.1.2, 9.8.5, 9.9.1, 9.10.2, 9.10.3, 13.2, 15.4.4.2
Consolidation or Joinder
15.4.4
CONSTRUCTION BY OWNER OR BY SEPARATE CONTRACTORS
1.1.4, **6**
Construction Change Directive, Definition of
7.3.1
Construction Change Directives
1.1.1, 3.4.2, 3.11, 3.12.8, 4.2.8, 7.1.1, 7.1.2, 7.1.3, **7.3**, 9.3.1.1
Construction Schedules, Contractor's
3.10, 3.11, 3.12.1, 3.12.2, 6.1.3, 15.1.6.2
Contingent Assignment of Subcontracts
5.4, 14.2.2.2
Continuing Contract Performance
15.1.4
Contract, Definition of
1.1.2
CONTRACT, TERMINATION OR SUSPENSION OF THE
5.4.1.1, 5.4.2, 11.5, **14**
Contract Administration
3.1.3, 4, 9.4, 9.5
Contract Award and Execution, Conditions Relating to
3.7.1, 3.10, 5.2, 6.1
Contract Documents, Copies Furnished and Use of
1.5.2, 2.3.6, 5.3
Contract Documents, Definition of
1.1.1
Contract Sum
2.2.2, 2.2.4, 3.7.4, 3.7.5, 3.8, 3.10.2, 5.2.3, 7.3, 7.4, **9.1**, 9.2, 9.4.2, 9.5.1.4, 9.6.7, **9.7**, 10.3.2, 11.5, 12.1.2, 12.3, 14.2.4, 14.3.2, 15.1.4.2, **15.1.5**, **15.2.5**
Contract Sum, Definition of
9.1
Contract Time
1.1.4, 2.2.1, 2.2.2, 3.7.4, 3.7.5, 3.10.2, 5.2.3, 6.1.5, 7.2.1.3, 7.3.1, 7.3.5, 7.3.6, 7, 7, 7.3.10, 7.4, 8.1.1, 8.2.1, 8.2.3, 8.3.1, 9.5.1, 9.7, 10.3.2, 12.1.1, 12.1.2, 14.3.2, 15.1.4.2, 15.1.6.1, 15.2.5
Contract Time, Definition of
8.1.1
CONTRACTOR
3
Contractor, Definition of
3.1, **6.1.2**
Contractor's Construction and Submittal Schedules
3.10, 3.12.1, 3.12.2, 4.2.3, 6.1.3, 15.1.6.2
Contractor's Employees

2.2.4, 3.3.2, 3.4.3, 3.8.1, 3.9, 3.18.2, 4.2.3, 4.2.6, 10.2, 10.3, 11.3, 14.1, 14.2.1.1

Contractor's Liability Insurance
11.1
 Contractor's Relationship with Separate Contractors and Owner's Forces
 3.12.5, 3.14.2, 4.2.4, 6, 11.3, 12.2.4
 Contractor's Relationship with Subcontractors
 1.2.2, 2.2.4, 3.3.2, 3.18.1, 3.18.2, 4.2.4, 5, 9.6.2, 9.6.7, 9.10.2, 11.2, 11.3, 11.4
 Contractor's Relationship with the Architect
 1.1.2, 1.5, 2.3.3, 3.1.3, 3.2.2, 3.2.3, 3.2.4, 3.3.1, 3.4.2, 3.5.1, 3.7.4, 3.10, 3.11, 3.12, 3.16, 3.18, 4.2, 5.2, 6.2.2, 7, 8.3.1, 9.2, 9.3, 9.4, 9.5, 9.7, 9.8, 9.9, 10.2.6, 10.3, 11.3, 12, 13.4, 15.1.3, 15.2.1
 Contractor's Representations
 3.2.1, 3.2.2, 3.5, 3.12.6, 6.2.2, 8.2.1, 9.3.3, 9.8.2
 Contractor's Responsibility for Those Performing the Work
 3.3.2, 3.18, 5.3, 6.1.3, 6.2, 9.5.1, 10.2.8
 Contractor's Review of Contract Documents
 3.2
 Contractor's Right to Stop the Work
 2.2.2, 9.7
 Contractor's Right to Terminate the Contract
 14.1
 Contractor's Submittals
 3.10, 3.11, 3.12, 4.2.7, 5.2.1, 5.2.3, 9.2, 9.3, 9.8.2, 9.8.3, 9.9.1, 9.10.2, 9.10.3
 Contractor's Superintendent
 3.9, 10.2.6
 Contractor's Supervision and Construction Procedures
 1.2.2, 3.3, 3.4, 3.12.10, 4.2.2, 4.2.7, 6.1.3, 6.2.4, 7.1.3, 7.3.4, 7.3.6, 8.2, 10, 12, 14, 15.1.4
 Coordination and Correlation
 1.2, 3.2.1, 3.3.1, 3.10, 3.12.6, 6.1.3, 6.2.1
 Copies Furnished of Drawings and Specifications
 1.5, 2.3.6, 3.11
 Copyrights
 1.5, **3.17**
 Correction of Work
 2.5, 3.7.3, 9.4.2, 9.8.2, 9.8.3, 9.9.1, 12.1.2, **12.2**, 12.3, 15.1.3.1, 15.1.3.2, 15.2.1

Correlation and Intent of the Contract Documents
1.2
Cost, Definition of
7.3.4
 Costs
 2.5, 3.2.4, 3.7.3, 3.8.2, 3.15.2, 5.4.2, 6.1.1, 6.2.3, 7.3.3.3, 7.3.4, 7.3.8, 7.3.9, 9.10.2, 10.3.2, 10.3.6, 11.2, 12.1.2, 12.2.1, 12.2.4, 13.4, 14

Cutting and Patching
3.14, 6.2.5
 Damage to Construction of Owner or Separate Contractors
 3.14.2, 6.2.4, 10.2.1.2, 10.2.5, 10.4, 12.2.4

Damage to the Work
 3.14.2, 9.9.1, 10.2.1.2, 10.2.5, 10.4, 12.2.4
 Damages, Claims for
 3.2.4, 3.18, 6.1.1, 8.3.3, 9.5.1, 9.6.7, 10.3.3, 11.3.2, 11.3, 14.2.4, 15.1.7
 Damages for Delay
 6.2.3, 8.3.3, 9.5.1.6, 9.7, 10.3.2, 14.3.2

Date of Commencement of the Work, Definition of
8.1.2

Date of Substantial Completion, Definition of
8.1.3

Day, Definition of
8.1.4

Decisions of the Architect
 3.7.4, 4.2.6, 4.2.7, 4.2.11, 4.2.12, 4.2.13, 6.3, 7.3.4, 7.3.9, 8.1.3, 8.3.1, 9.2, 9.4, 9.5.1, 9.8.4, 9.9.1, 13.4.2, 14.2.2, 14.2.4, 15.1, 15.2

Decisions to Withhold Certification
 9.4.1, **9.5**, 9.7, 14.1.1.3
 Defective or Nonconforming Work, Acceptance, Rejection and Correction of
 2.5, 3.5, 4.2.6, 6.2.3, 9.5.1, 9.5.3, 9.6.6, 9.8.2, 9.9.3, 9.10.4, 12.2.1
 Definitions
 1.1, 2.1.1, 3.1.1, 3.5, 3.12.1, 3.12.2, 3.12.3, 4.1.1, 5.1, 6.1.2, 7.2.1, 7.3.1, 8.1, 9.1, 9.8.1, 15.1.1

Delays and Extensions of Time
3.2, **3.7.4**, 5.2.3, 7.2.1, 7.3.1, **7.4**, **8.3**, 9.5.1, **9.7**, 10.3.2, **10.4**, 14.3.2, **15.1.6**, **15.2.5**

Digital Data Use and Transmission
1.7
 Disputes
 6.3, 7.3.9, 15.1, 15.2

Documents and Samples at the Site
3.11
Drawings, Definition of
1.1.5
 Drawings and Specifications, Use and Ownership of
 3.11
 Effective Date of Insurance
 8.2.2

Emergencies
10.4, 14.1.1.2, **15.1.5**
 Employees, Contractor's
 3.3.2, 3.4.3, 3.8.1, 3.9, 3.18.2, 4.2.3, 4.2.6, 10.2, 10.3.3, 11.3, 14.1, 14.2.1.1
 Equipment, Labor, or Materials
 1.1.3, 1.1.6, 3.4, 3.5, 3.8.2, 3.8.3, 3.12, 3.13, 3.15.1, 4.2.6, 4.2.7, 5.2.1, 6.2.1, 7.3.4, 9.3.2, 9.3.3, 9.5.1.3, 9.10.2, 10.2.1, 10.2.4, 14.2.1.1, 14.2.1.2
 Execution and Progress of the Work
 1.1.3, 1.2.1, 1.2.2, 2.3.4, 2.3.6, 3.1, 3.3.1, 3.4.1, 3.7.1, 3.10.1, 3.12, 3.14, 4.2, 6.2.2, 7.1.3, 7.3.6, 8.2, 9.5.1, 9.9.1, 10.2, 10.3, 12.1, 12.2, 14.2, 14.3.1, 15.1.4
 Extensions of Time
 3.2.4, 3.7.4, 5.2.3, 7.2.1, 7.3, 7.4, 9.5.1, 9.7, 10.3.2, 10.4, 14.3, 15.1.6, **15.2.5**

Failure of Payment

9.5.1.3, **9.7**, 9.10.2, 13.5, 14.1.1.3, 14.2.1.2

Faulty Work

(See Defective or Nonconforming Work)

Final Completion and Final Payment

4.2.1, 4.2.9, 9.8.2, **9.10**, 12.3, 14.2.4, 14.4.3

Financial Arrangements, Owner's

2.2.1, 13.2.2, 14.1.1.4

GENERAL PROVISIONS

1

Governing Law

13.1

Guarantees (See Warranty)

Hazardous Materials and Substances

10.2.4, 10.3

Identification of Subcontractors and Suppliers

5.2.1

Indemnification

3.17, **3.18**, 9.6.8, 9.10.2, 10.3.3, 11.3

Information and Services Required of the Owner

2.1.2, **2.2**, 2.3, 3.2.2, 3.12.10.1, 6.1.3, 6.1.4, 6.2.5,

9.6.1, 9.9.2, 9.10.3, 10.3.3, 11.2, 13.4.1, 13.4.2,

14.1.1.4, 14.1.4, 15.1.4

Initial Decision

15.2

Initial Decision Maker, Definition of

1.1.8

Initial Decision Maker, Decisions

14.2.4, 15.1.4.2, 15.2.1, 15.2.2, 15.2.3, 15.2.4, 15.2.5

Initial Decision Maker, Extent of Authority

14.2.4, 15.1.4.2, 15.2.1, 15.2.2, 15.2.3, 15.2.4, 15.2.5

Injury or Damage to Person or Property

10.2.8, 10.4

Inspections

3.1.3, 3.3.3, 3.7.1, 4.2.2, 4.2.6, 4.2.9, 9.4.2, 9.8.3,

9.9.2, 9.10.1, 12.2.1, 13.4

Instructions to Bidders

1.1.1

Instructions to the Contractor

3.2.4, 3.3.1, 3.8.1, 5.2.1, 7, 8.2.2, 12, 13.4.2

Instruments of Service, Definition of

1.1.7

Insurance

6.1.1, 7.3.4, 8.2.2, 9.3.2, 9.8.4, 9.9.1, 9.10.2, 10.2.5,

11

Insurance, Notice of Cancellation or Expiration

11.1.4, 11.2.3

Insurance, Contractor's Liability

11.1

Insurance, Effective Date of

8.2.2, 14.4.2

Insurance, Owner's Liability

11.2

Insurance, Property

10.2.5, 11.2, 11.4, 11.5

Insurance, Stored Materials

9.3.2

INSURANCE AND BONDS

11

Insurance Companies, Consent to Partial Occupancy

9.9.1

Insured loss, Adjustment and Settlement of

11.5

Intent of the Contract Documents

1.2.1, 4.2.7, 4.2.12, 4.2.13

Interest

13.5

Interpretation

1.1.8, 1.2.3, **1.4**, 4.1.1, 5.1, 6.1.2, 15.1.1

Interpretations, Written

4.2.11, 4.2.12

Judgment on Final Award

15.4.2

Labor and Materials, Equipment

1.1.3, 1.1.6, **3.4**, 3.5, 3.8.2, 3.8.3, 3.12, 3.13, 3.15.1,

5.2.1, 6.2.1, 7.3.4, 9.3.2, 9.3.3, 9.5.1.3, 9.10.2, 10.2.1,

10.2.4, 14.2.1.1, 14.2.1.2

Labor Disputes

8.3.1

Laws and Regulations

1.5, 2.3.2, 3.2.3, 3.2.4, 3.6, 3.7, 3.12.10, 3.13, 9.6.4,

9.9.1, 10.2.2, 13.1, 13.3.1, 13.4.2, 13.5, 14, 15.2.8,

15.4

Liens

2.1.2, 9.3.1, 9.3.3, 9.6.8, 9.10.2, 9.10.4, 15.2.8

Limitations, Statutes of

12.2.5, 15.1.2, 15.4.1.1

Limitations of Liability

3.2.2, 3.5, 3.12.10, 3.12.10.1, 3.17, 3.18.1, 4.2.6,

4.2.7, 6.2.2, 9.4.2, 9.6.4, 9.6.7, 9.6.8, 10.2.5, 10.3.3,

11.3, 12.2.5, 13.3.1

Limitations of Time

2.1.2, 2.2, 2.5, 3.2.2, 3.10, 3.11, 3.12.5, 3.15.1, 4.2.7,

5.2, 5.3, 5.4.1, 6.2.4, 7.3, 7.4, 8.2, 9.2, 9.3.1, 9.3.3,

9.4.1, 9.5, 9.6, 9.7, 9.8, 9.9, 9.10, 12.2, 13.4, 14, 15,

15.1.2, 15.1.3, 15.1.5

Materials, Hazardous

10.2.4, 10.3

Materials, Labor, Equipment and

1.1.3, 1.1.6, 3.4.1, 3.5, 3.8.2, 3.8.3, 3.12, 3.13, 3.15.1,

5.2.1, 6.2.1, 7.3.4, 9.3.2, 9.3.3, 9.5.1.3, 9.10.2,

10.2.1.2, 10.2.4, 14.2.1.1, 14.2.1.2

Means, Methods, Techniques, Sequences and

Procedures of Construction

3.3.1, 3.12.10, 4.2.2, 4.2.7, 9.4.2

Mechanic's Lien

2.1.2, 9.3.1, 9.3.3, 9.6.8, 9.10.2, 9.10.4, 15.2.8

Mediation

8.3.1, 15.1.3.2, 15.2.1, 15.2.5, 15.2.6, **15.3**, 15.4.1,

15.4.1.1

Minor Changes in the Work

1.1.1, 3.4.2, 3.12.8, 4.2.8, 7.1, **7.4**

MISCELLANEOUS PROVISIONS

13

Modifications, Definition of
1.1.1
Modifications to the Contract
1.1.1, 1.1.2, 2.5, 3.11, 4.1.2, 4.2.1, 5.2.3, 7, 8.3.1, 9.7, 10.3.2

Mutual Responsibility
6.2
Nonconforming Work, Acceptance of
9.6.6, 9.9.3, **12.3**
Nonconforming Work, Rejection and Correction of
2.4, 2.5, 3.5, 4.2.6, 6.2.4, 9.5.1, 9.8.2, 9.9.3, 9.10.4, 12.2

Notice
1.6, 1.6.1, 1.6.2, 2.1.2, 2.2.2., 2.2.3, 2.2.4, 2.5, 3.2.4, 3.3.1, 3.7.4, 3.7.5, 3.9.2, 3.12.9, 3.12.10, 5.2.1, 7.4, 8.2.2, 9.6.8, 9.7, 9.10.1, 10.2.8, 10.3.2, 11.5, 12.2.2.1, 13.4.1, 13.4.2, 14.1, 14.2.2, 14.4.2, 15.1.3, 15.1.5, 15.1.6, 15.4.1

Notice of Cancellation or Expiration of Insurance
11.1.4, 11.2.3

Notice of Claims
1.6.2, 2.1.2, 3.7.4, 9.6.8, 10.2.8, **15.1.3**, 15.1.5, 15.1.6, 15.2.8, 15.3.2, 15.4.1

Notice of Testing and Inspections
13.4.1, 13.4.2

Observations, Contractor's
3.2, 3.7.4

Occupancy
2.3.1, 9.6.6, 9.8

Orders, Written
1.1.1, 2.4, 3.9.2, 7, 8.2.2, 11.5, 12.1, 12.2.2.1, 13.4.2, 14.3.1

OWNER
2
Owner, Definition of
2.1.1
Owner, Evidence of Financial Arrangements
2.2, 13.2.2, 14.1.1.4

Owner, Information and Services Required of the
2.1.2, **2.2**, 2.3, 3.2.2, 3.12.10, 6.1.3, 6.1.4, 6.2.5, 9.3.2, 9.6.1, 9.6.4, 9.9.2, 9.10.3, 10.3.3, 11.2, 13.4.1, 13.4.2, 14.1.1.4, 14.1.4, 15.1.4

Owner's Authority
1.5, 2.1.1, 2.3.32.4, 2.5, 3.4.2, 3.8.1, 3.12.10, 3.14.2, 4.1.2, 4.2.4, 4.2.9, 5.2.1, 5.2.4, 5.4.1, 6.1, 6.3, 7.2.1, 7.3.1, 8.2.2, 8.3.1, 9.3.2, 9.5.1, 9.6.4, 9.9.1, 9.10.2, 10.3.2, 11.4, 11.5, 12.2.2, 12.3, 13.2.2, 14.3, 14.4, 15.2.7

Owner's Insurance
11.2
Owner's Relationship with Subcontractors
1.1.2, 5.2, 5.3, 5.4, 9.6.4, 9.10.2, 14.2.2

Owner's Right to Carry Out the Work
2.5, 14.2.2

Owner's Right to Clean Up
6.3
Owner's Right to Perform Construction and to

Award Separate Contracts
6.1
Owner's Right to Stop the Work
2.4
Owner's Right to Suspend the Work
14.3
Owner's Right to Terminate the Contract
14.2, 14.4

Ownership and Use of Drawings, Specifications and Other Instruments of Service
1.1.1, 1.1.6, 1.1.7, **1.5**, 2.3.6, 3.2.2, 3.11, 3.17, 4.2.12, 5.3

Partial Occupancy or Use
9.6.6, **9.9**

Patching, Cutting and
3.14, 6.2.5

Patents
3.17

Payment, Applications for
4.2.5, 7.3.9, 9.2, **9.3**, 9.4, 9.5, 9.6.3, 9.7, 9.8.5, 9.10.1, 14.2.3, 14.2.4, 14.4.3

Payment, Certificates for
4.2.5, 4.2.9, 9.3.3, **9.4**, 9.5, 9.6.1, 9.6.6, 9.7, 9.10.1, 9.10.3, 14.1.1.3, 14.2.4

Payment, Failure of
9.5.1.3, **9.7**, 9.10.2, 13.5, 14.1.1.3, 14.2.1.2

Payment, Final
4.2.1, 4.2.9, **9.10**, 12.3, 14.2.4, 14.4.3

Payment Bond, Performance Bond and
7.3.4.4, 9.6.7, 9.10.3, **11.1.2**

Payments, Progress
9.3, **9.6**, 9.8.5, 9.10.3, 14.2.3, 15.1.4

PAYMENTS AND COMPLETION
9
Payments to Subcontractors
5.4.2, 9.5.1.3, 9.6.2, 9.6.3, 9.6.4, 9.6.7, 14.2.1.2

PCB
10.3.1

Performance Bond and Payment Bond
7.3.4.4, 9.6.7, 9.10.3, **11.1.2**

Permits, Fees, Notices and Compliance with Laws
2.3.1, **3.7**, 3.13, 7.3.4.4, 10.2.2

PERSONS AND PROPERTY, PROTECTION OF
10
Polychlorinated Biphenyl
10.3.1

Product Data, Definition of
3.12.2

Product Data and Samples, Shop Drawings
3.11, **3.12**, 4.2.7

Progress and Completion
4.2.2, **8.2**, 9.8, 9.9.1, 14.1.4, 15.1.4

Progress Payments
9.3, **9.6**, 9.8.5, 9.10.3, 14.2.3, 15.1.4

Project, Definition of
1.1.4

Project Representatives
4.2.10
Property Insurance
10.2.5, 11.2
Proposal Requirements
1.1.1
PROTECTION OF PERSONS AND PROPERTY
10
Regulations and Laws
1.5, 2.3.2, 3.2.3, 3.6, 3.7, 3.12.10, 3.13, 9.6.4, 9.9.1,
10.2.2, 13.1, 13.3, 13.4.1, 13.4.2, 13.5, 14, 15.2.8,
15.4
Rejection of Work
4.2.6, 12.2.1
Releases and Waivers of Liens
9.3.1, 9.10.2
Representations
3.2.1, 3.5, 3.12.6, 8.2.1, 9.3.3, 9.4.2, 9.5.1, 9.10.1
Representatives
2.1.1, 3.1.1, 3.9, 4.1.1, 4.2.10, 13.2.1
Responsibility for Those Performing the Work
3.3.2, 3.18, 4.2.2, 4.2.3, 5.3, 6.1.3, 6.2, 6.3, 9.5.1, 10
Retainage
9.3.1, 9.6.2, 9.8.5, 9.9.1, 9.10.2, 9.10.3
Review of Contract Documents and Field
Conditions by Contractor
3.2, 3.12.7, 6.1.3
Review of Contractor's Submittals by Owner and
Architect
3.10.1, 3.10.2, 3.11, 3.12, 4.2, 5.2, 6.1.3, 9.2, 9.8.2
Review of Shop Drawings, Product Data and
Samples by Contractor
3.12
Rights and Remedies
1.1.2, 2.4, 2.5, 3.5, 3.7.4, 3.15.2, 4.2.6, 5.3, 5.4, 6.1,
6.3, 7.3.1, 8.3, 9.5.1, 9.7, 10.2.5, 10.3, 12.2.1, 12.2.2,
12.2.4, 13.3, 14, 15.4
Royalties, Patents and Copyrights
3.17
Rules and Notices for Arbitration
15.4.1
Safety of Persons and Property
10.2, 10.4
Safety Precautions and Programs
3.3.1, 4.2.2, 4.2.7, 5.3, 10.1, 10.2, 10.4
Samples, Definition of
3.12.3
Samples, Shop Drawings, Product Data and
3.11, 3.12, 4.2.7
Samples at the Site, Documents and
3.11
Schedule of Values
9.2, 9.3.1
Schedules, Construction
3.10, 3.12.1, 3.12.2, 6.1.3, 15.1.6.2
Separate Contracts and Contractors
1.1.4, 3.12.5, 3.14.2, 4.2.4, 4.2.7, 6, 8.3.1, 12.1.2

Separate Contractors, Definition of
6.1.1
Shop Drawings, Definition of
3.12.1
Shop Drawings, Product Data and Samples
3.11, 3.12, 4.2.7
Site, Use of
3.13, 6.1.1, 6.2.1
Site Inspections
3.2.2, 3.3.3, 3.7.1, 3.7.4, 4.2, 9.9.2, 9.4.2, 9.10.1, 13.4
Site Visits, Architect's
3.7.4, 4.2.2, 4.2.9, 9.4.2, 9.5.1, 9.9.2, 9.10.1, 13.4
Special Inspections and Testing
4.2.6, 12.2.1, 13.4
Specifications, Definition of
1.1.6
Specifications
1.1.1, 1.1.6, 1.2.2, 1.5, 3.12.10, 3.17, 4.2.14
Statute of Limitations
15.1.2, 15.4.1.1
Stopping the Work
2.2.2, 2.4, 9.7, 10.3, 14.1
Stored Materials
6.2.1, 9.3.2, 10.2.1.2, 10.2.4
Subcontractor, Definition of
5.1.1
SUBCONTRACTORS
5
Subcontractors, Work by
1.2.2, 3.3.2, 3.12.1, 3.18, 4.2.3, 5.2.3, 5.3, 5.4,
9.3.1.2, 9.6.7
Subcontractual Relations
5.3, 5.4, 9.3.1.2, 9.6, 9.10, 10.2.1, 14.1, 14.2.1
Submittals
3.10, 3.11, 3.12, 4.2.7, 5.2.1, 5.2.3, 7.3.4, 9.2, 9.3,
9.8, 9.9.1, 9.10.2, 9.10.3
Submittal Schedule
3.10.2, 3.12.5, 4.2.7
Subrogation, Waivers of
6.1.1, 11.3
Substances, Hazardous
10.3
Substantial Completion
4.2.9, 8.1.1, 8.1.3, 8.2.3, 9.4.2, 9.8, 9.9.1, 9.10.3,
12.2, 15.1.2
Substantial Completion, Definition of
9.8.1
Substitution of Subcontractors
5.2.3, 5.2.4
Substitution of Architect
2.3.3
Substitutions of Materials
3.4.2, 3.5, 7.3.8
Sub-subcontractor, Definition of
5.1.2
Subsurface Conditions
3.7.4

Successors and Assigns

13.2

Superintendent

3.9, 10.2.6

Supervision and Construction Procedures

1.2.2, 3.3, 3.4, 3.12.10, 4.2.2, 4.2.7, 6.1.3, 6.2.4, 7.1.3, 7.3.4, 8.2, 8.3.1, 9.4.2, 10, 12, 14, 15.1.4

Suppliers

1.5, 3.12.1, 4.2.4, 4.2.6, 5.2.1, 9.3, 9.4.2, 9.5.4, 9.6, 9.10.5, 14.2.1

Surety

5.4.1.2, 9.6.8, 9.8.5, 9.10.2, 9.10.3, 11.1.2, 14.2.2, 15.2.7

Surety, Consent of

9.8.5, 9.10.2, 9.10.3

Surveys

1.1.7, 2.3.4

Suspension by the Owner for Convenience

14.3

Suspension of the Work

3.7.5, 5.4.2, 14.3

Suspension or Termination of the Contract

5.4.1.1, 14

Taxes

3.6, 3.8.2.1, 7.3.4.4

Termination by the Contractor

14.1, 15.1.7

Termination by the Owner for Cause

5.4.1.1, 14.2, 15.1.7

Termination by the Owner for Convenience

14.4

Termination of the Architect

2.3.3

Termination of the Contractor Employment

14.2.2

TERMINATION OR SUSPENSION OF THE CONTRACT

14

Tests and Inspections

3.1.3, 3.3.3, 3.7.1, 4.2.2, 4.2.6, 4.2.9, 9.4.2, 9.8.3, 9.9.2, 9.10.1, 10.3.2, 12.2.1, 13.4

TIME

8

Time, Delays and Extensions of

3.2.4, 3.7.4, 5.2.3, 7.2.1, 7.3.1, 7.4, 8.3, 9.5.1, 9.7, 10.3.2, 10.4, 14.3.2, 15.1.6, 15.2.5

Time Limits

2.1.2, 2.2, 2.5, 3.2.2, 3.10, 3.11, 3.12.5, 3.15.1, 4.2, 5.2, 5.3, 5.4, 6.2.4, 7.3, 7.4, 8.2, 9.2, 9.3.1, 9.3.3, 9.4.1, 9.5, 9.6, 9.7, 9.8, 9.9, 9.10, 12.2, 13.4, 14, 15.1.2, 15.1.3, 15.4

Time Limits on Claims

3.7.4, 10.2.8, 15.1.2, 15.1.3

Title to Work

9.3.2, 9.3.3

UNCOVERING AND CORRECTION OF WORK

12

Uncovering of Work

12.1

Unforeseen Conditions, Concealed or Unknown

3.7.4, 8.3.1, 10.3

Unit Prices

7.3.3.2, 9.1.2

Use of Documents

1.1.1, 1.5, 2.3.6, 3.12.6, 5.3

Use of Site

3.13, 6.1.1, 6.2.1

Values, Schedule of

9.2, 9.3.1

Waiver of Claims by the Architect

13.3.2

Waiver of Claims by the Contractor

9.10.5, 13.3.2, 15.1.7

Waiver of Claims by the Owner

9.9.3, 9.10.3, 9.10.4, 12.2.2.1, 13.3.2, 14.2.4, 15.1.7

Waiver of Consequential Damages

14.2.4, 15.1.7

Waiver of Liens

9.3, 9.10.2, 9.10.4

Waivers of Subrogation

6.1.1, 11.3

Warranty

3.5, 4.2.9, 9.3.3, 9.8.4, 9.9.1, 9.10.2, 9.10.4, 12.2.2, 15.1.2

Weather Delays

8.3, 15.1.6.2

Work, Definition of

1.1.3

Written Consent

1.5.2, 3.4.2, 3.7.4, 3.12.8, 3.14.2, 4.1.2, 9.3.2, 9.10.3, 13.2, 13.3.2, 15.4.4.2

Written Interpretations

4.2.11, 4.2.12

Written Orders

1.1.1, 2.4, 3.9, 7, 8.2.2, 12.1, 12.2, 13.4.2, 14.3.1

ARTICLE 1 GENERAL PROVISIONS

§ 1.1 Basic Definitions

§ 1.1.1 The Contract Documents

The Contract Documents are enumerated in the Agreement between the Owner and Contractor (hereinafter the Agreement) and consist of the Agreement, Conditions of the Contract (General, Supplementary and other Conditions), Drawings, Specifications, Addenda issued prior to execution of the Contract, other documents listed in the Agreement, and Modifications issued after execution of the Contract. A Modification is (1) a written amendment to the Contract signed by both parties, (2) a Change Order, (3) a Construction Change Directive, or (4) a written order for a minor change in the Work issued by the Architect. Unless specifically enumerated in the Agreement, the Contract Documents do not include the advertisement or invitation to bid, Instructions to Bidders, sample forms, other information furnished by the Owner in anticipation of receiving bids or proposals, the Contractor's bid or proposal, or portions of Addenda relating to bidding or proposal requirements.

§ 1.1.2 The Contract

The Contract Documents form the Contract for Construction. The Contract represents the entire and integrated agreement between the parties hereto and supersedes prior negotiations, representations, or agreements, either written or oral. The Contract may be amended or modified only by a Modification. The Contract Documents shall not be construed to create a contractual relationship of any kind (1) between the Contractor and the Architect or the Architect's consultants, (2) between the Owner and a Subcontractor or a Sub-subcontractor, (3) between the Owner and the Architect or the Architect's consultants, or (4) between any persons or entities other than the Owner and the Contractor. The Architect shall, however, be entitled to performance and enforcement of obligations under the Contract intended to facilitate performance of the Architect's duties.

In the event of conflicts or discrepancies among the Contract Documents, interpretations will be based on the following priorities:

- .1 Modifications, with those of later date having precedence over those of earlier date.
- .2 The Agreement, including any amendment to the Agreement included in the bid package.
- .3 Addenda to the Specifications and Drawings, with those of later date having precedence over those of earlier date.
- .4 The General Conditions of the Contract for Construction.
- .5 Specifications and Drawings.

Further, stated dimensions shall take precedence over scaled dimensions; large-scale detail drawings shall take precedence over small-scale drawings; schedules shall take precedence over other data on the drawings.

In the case of an inconsistency between Drawings and Specifications or within either Document in describing the Work, the better quality, greater quantity, or more costly work shall be provided in accordance with the Architect's interpretation.

§ 1.1.3 The Work

The term "Work" means the construction and services required by the Contract Documents, whether performed on or off the site of the Project and whether completed or partially completed, and includes all other labor, materials, equipment, and services provided or to be provided by the Contractor, its Subcontractors, Sub-Subcontractors, material suppliers or any other entity for whom the Contractor is responsible to fulfill the Contractor's obligations. The Work may constitute the whole or a part of the Project.

§ 1.1.4 The Project

The Project is the total construction of which the Work performed under the Contract Documents may be the whole or a part and which may include construction by the Owner and by Separate Contractors.

§ 1.1.5 The Drawings

The Drawings are the graphic and pictorial portions of the Contract Documents showing the design, location and dimensions of the Work, generally including plans, elevations, sections, details, schedules, and diagrams.

§ 1.1.6 The Specifications

The Specifications are that portion of the Contract Documents consisting of the written requirements for materials, equipment, systems, standards and workmanship for the Work, and performance of related services.

§ 1.1.7 Instruments of Service

Instruments of Service are representations, in any medium of expression now known or later developed, of the tangible and intangible creative work performed by the Architect and the Architect's consultants under their respective professional services agreements. Instruments of Service may include, without limitation, studies, surveys, models, sketches, drawings, specifications, and other similar materials.

§ 1.1.8 Contractor's Standard of Care

The Contractor shall be responsible for the performance of the Work as an independent contractor and in a good and workmanlike manner (i) consistent with the Contract Documents; (ii) consistent with the instructions, guidance and direction of the Owner and Architect; (iii) consistent with the highest prevailing applicable professional or industry standards; (iv) consistent with sound practices; (v) as expeditiously as is consistent with such professional skill and care and the orderly progress of the Work and with the Contract Documents and the instructions, guidance and direction of the Owner and Architect; and (vi) in a manner that will not exceed the Contract Sum as set forth in the Agreement (the standards of this Section 1.1.8 shall be referred to herein as the "Contractor's Standard of Care"). The Contractor shall exercise the Contractor's Standard of Care in performing all aspects of the Work. All references in the Contract Documents to the knowledge, inference, reliance, awareness, determination, belief, observation, recognition or discovery of the Contractor or reference to any similar term shall include the constructive knowledge, inference, reliance, awareness, determination, belief, observation and recognition attributed to the Contractor ("constructive knowledge"). Such constructive knowledge shall include the knowledge, inference, reliance, awareness, determination, belief, observation and recognition the Contractor would have obtained upon the exercise of the Contractor's Standard of Care.

§ 1.1.9 Initial Decision Maker

The Initial Decision Maker is the person identified in the Agreement to render initial decisions on Claims in accordance with Section 15.2. The Initial Decision Maker shall not show partiality to the Owner or Contractor and shall not be liable for results of interpretations or decisions rendered in good faith.

§ 1.2 Correlation and Intent of the Contract Documents

§ 1.2.1 The intent of the Contract Documents is to include all items necessary for the proper execution and completion of the Work by the Contractor. The Contract Documents are complementary, and what is required by one shall be as binding as if required by all; performance by the Contractor shall be required only to the extent consistent with the Contract Documents and reasonably inferable from them as being necessary to produce the indicated results.

.1 Before ordering materials or doing any Work, the Contractor and each Subcontractor shall verify measurements at the Project site and shall be responsible for the correctness of such measurements. No extra charge or compensation will be allowed on account of minor differences between actual dimensions and the dimensions indicated on the Drawings. Any difference which may be found shall be submitted to the Architect for resolution before proceeding with the Work.

.2 If a minor change in the Work is found necessary due to actual field conditions, the Contractor shall submit detailed drawings of such departure for the approval by the Architect before making the change.

§ 1.2.1.2 The Architect may, as he deems desirable, issue additional drawings or instructions indicating in greater detail the construction or design of the various parts of the Work reasonably inferable from the Contract Documents; such drawings or instructions may be effected by notice to the Contractor without modification of the contract Time or contract Sum. If the Contractor claims additional cost or delay on account of such additional drawings or instructions, he shall give notice as provided in Subparagraph 15.1.

§ 1.2.1.1 The invalidity of any provision of the Contract Documents shall not invalidate the Contract or its remaining provisions. If it is determined that any provision of the Contract Documents violates any law, or is otherwise invalid or unenforceable, then that provision shall be revised to the extent necessary to make that provision legal and enforceable. In such case the Contract Documents shall be construed, to the fullest extent permitted by law, to give effect to the parties' intentions and purposes in executing the Contract.

§ 1.2.2 Organization of the Specifications into divisions, sections and articles, and arrangement of Drawings shall not control the Contractor in dividing the Work among Subcontractors or in establishing the extent of Work to be performed by any trade.

§ 1.2.3 Unless otherwise stated in the Contract Documents, words that have well-known technical or construction industry meanings are used in the Contract Documents in accordance with such recognized meanings.

§ 1.2.4 The Contractor and all Subcontractors shall refer to all of the Drawings, including those showing primarily the Work of the mechanical, electrical and other specialized trades, and to all of the sections of the Specifications, and shall perform all Work reasonably inferable there from as being necessary to produce the indicated results.

§ 1.3 Capitalization

Terms capitalized in these General Conditions include those that are (1) specifically defined, (2) the titles of numbered articles, or (3) the titles of other documents published by the American Institute of Architects.

§ 1.4 Interpretation

In the interest of brevity the Contract Documents frequently omit modifying words such as "all" and "any" and articles such as "the" and "an," but the fact that a modifier or an article is absent from one statement and appears in another is not intended to affect the interpretation of either statement.

§ 1.5 Ownership and Use of Drawings, Specifications, and Other Instruments of Service

§ 1.5.1 The Instruments of Service, including the Drawings and Specifications, are and shall be the property of the Owner. The Contractor, Subcontractors, Sub-subcontractors, and suppliers shall not own or claim a copyright in the Instruments of Service. Submittal or distribution to meet official regulatory requirements or for other purposes in connection with the Project is not to be construed as publication in derogation of the reserved rights of the Owner.

§ 1.5.2 The Contractor, Subcontractors, Sub-subcontractors, and suppliers are authorized to use and reproduce the Instruments of Service provided to them, subject to any protocols established pursuant to Sections 1.7 and 1.8, solely and exclusively for execution of the Work. All copies made under this authorization shall bear the copyright notice, if any, shown on the Instruments of Service. The Contractor, Subcontractors, Sub-subcontractors, and suppliers may not use the Instruments of Service for any purpose outside the scope of the Work without the specific written consent of the Owner

§ 1.5.3 Prior to execution of the Agreement, the Contractor evaluated and satisfied itself as to the condition and limitations under which the Work is to be performed, including, without limitation, (i) the location, condition, layout, and nature of the Project site and surrounding areas, (ii) generally prevailing climatic conditions, (iii) anticipated labor supply and costs, (iv) availability and cost of materials, tools, and equipment, and (v) other similar issues. The Owner assumes no responsibility or liability for the physical condition or safety of the Project site or any improvements located on the Project site. The Contractor shall be solely responsible for providing a safe place for the performance of the Work. The Owner shall not be required to make any adjustment in either the Contract Sum or the Contract Time in connection with any failure by the Contractor or any Subcontractor to have complied with the requirements of this Subparagraph 1.5.3.

§ 1.6 Notice

§ 1.6.1 Except as otherwise provided in Section 1.6.2, where the Contract Documents require one party to notify or give notice to the other party, such notice shall be provided in writing to the designated representative of the party to whom the notice is addressed and shall be deemed to have been duly served if delivered in person, by mail, by courier, or by electronic transmission if a method for electronic transmission is set forth in the Agreement.

§ 1.6.2 Notice of Claims as provided in Section 15.1.3 shall be provided in writing and shall be deemed to have been duly served only if delivered to the designated representative of the party to whom the notice is addressed by certified or registered mail, or by courier providing proof of delivery.

§ 1.7 Digital Data Use and Transmission

The parties shall agree upon protocols governing the transmission and use of Instruments of Service or any other information or documentation in digital form. The parties will use AIA Document E203™–2013, Building Information Modeling and Digital Data Exhibit, to establish the protocols for the development, use, transmission, and exchange of digital data.

§ 1.8 Building Information Models Use and Reliance

Any use of, or reliance on, all or a portion of a building information model without agreement to protocols governing the use of, and reliance on, the information contained in the model and without having those protocols set forth in AIA Document E203™–2013, Building Information Modeling and Digital Data Exhibit, and the requisite AIA Document G202™–2013, Project Building Information Modeling Protocol Form, shall be at the using or relying party's sole risk and without liability to the other party and its contractors or consultants, the authors of, or contributors to, the building information model, and each of their agents and employees.

§ 1.9 Any information obtained by the Contractor from the Owner or Architect may not be used, published, distributed, sold or divulged by the Contractor or its Subcontractor or Sub-subcontractors for such party's own purposes or for the benefit of any person, firm, corporation or other entity other than the Owner, without the prior written consent of the Owner. Any information obtained by the Contractor of its Subcontractors or Sub-Subcontractors that is designated by the Owner in accordance with applicable law as confidential shall not be disclosed to any other parties without the prior written consent of the Owner.

ARTICLE 2 OWNER

§ 2.1 General

§ 2.1.1 INTENTIONALLY OMITTED

§ 2.1.2 INTENTIONALLY OMITTED

§ 2.2 Evidence of the Owner's Financial Arrangements

§ 2.2.1

INTENTIONALLY OMITTED

§ 2.3 Information and Services Required of the Owner

§ 2.3.1 Except for permits and fees that are the responsibility of the Contractor under the Contract Documents, including those required under Section 3.7.1, the Owner shall secure and pay for necessary approvals, easements, assessments and charges required for construction, use or occupancy of permanent structures or for permanent changes in existing facilities. The Owner has agreed to waive the cost of building permits.

§ 2.3.2 The Owner shall retain an architect lawfully licensed to practice architecture, or an entity lawfully practicing architecture, in the jurisdiction where the Project is located. That person or entity is identified as the Architect in the Agreement and is referred to throughout the Contract Documents as if singular in number.

§ 2.3.3 If the employment of the Architect terminates, the Owner shall employ a successor to whom the Contractor has no reasonable objection and whose status under the Contract Documents shall be that of the Architect.

§ 2.3.4 The Owner shall furnish surveys describing physical characteristics, legal limitations and utility locations for the site of the Project, and a legal description of the site.

§ 2.3.5 The Owner shall furnish information or services required of the Owner by the Contract Documents with reasonable promptness. The Owner shall also furnish any other information or services under the Owner's control and relevant to the Contractor's performance of the Work with reasonable promptness after receiving the Contractor's written request for such information or services.

§ 2.3.6 Unless otherwise provided in the Contract Documents, the Owner shall furnish to the Contractor one copy of the Contract Documents for purposes of making reproductions pursuant to Section 1.5.2.

§ 2.4 Owner's Right to Stop the Work

If the Contractor fails to correct Work that is not in accordance with the requirements of the Contract Documents as required by Section 12.2 or fails to carry out Work in accordance with the Contract Documents, the Owner may issue a written order to the Contractor to stop the Work, or any portion thereof, however, the right of the Owner to stop the Work shall not give rise to a duty on the part of the Owner to exercise this right for the benefit of the Contractor or any other person or entity, except to the extent required by Section 6.1.3.

§ 2.5 Owner's Right to Carry Out the Work

If the Contractor defaults or neglects to carry out the Work in accordance with the Contract Documents and fails within a seven-day period after receipt of notice from the Owner to commence and continue correction of such default or neglect with diligence and promptness, the Owner may, without prejudice to other remedies the Owner may have, correct such default or neglect. Such action by the Owner and amounts charged to the Contractor are both subject to prior approval of the Architect and the Architect may, pursuant to Section 9.5.1, withhold or nullify a Certificate for Payment in whole or in part, to the extent reasonably necessary to reimburse the Owner for the reasonable cost of correcting such deficiencies, including Owner's expenses and compensation for the Architect's additional services made necessary by such default, neglect, or failure. If current and future payments are not sufficient to cover such amounts, the Contractor shall pay the difference to the Owner. If the Contractor disagrees with the actions of the Owner or the Architect, or the amounts claimed as costs to the Owner, the Contractor may file a Claim pursuant to Article 15. The Owner's right to stop the Work is in addition to and not in restriction or derogation of any and all remedies available to the Owner.

§ 2.6 In no event shall the Owner have control over, charge or any responsibility for construction means, methods, techniques, sequences, or procedures or for safety precautions and programs in connection with the Work, notwithstanding any of the rights and authority granted the Owner in the Contract Documents.

ARTICLE 3 CONTRACTOR

§ 3.1 General

§ 3.1.1 The Contractor is the person or entity identified as such in the Agreement and is referred to throughout the Contract Documents as if singular in number. The Contractor shall be lawfully licensed, if required in the jurisdiction where the Project is located. The Contractor shall designate in writing a representative who shall have express authority to bind the Contractor with respect to all matters under this Contract. The term "Contractor" means the Contractor or the Contractor's authorized representative.

§ 3.1.2 The Contractor shall perform the Work in accordance with the Contract Documents.

§ 3.1.3 The Contractor shall not be relieved of its obligations to perform the Work in accordance with the Contract Documents either by activities or duties of the Architect in the Architect's administration of the Contract, or by tests, inspections or approvals required or performed by persons or entities other than the Contractor.

§ 3.1.4 The Contractor shall comply with the Conditions and all local, state and federal laws, rules and regulations applicable to the Contractor, including without limitation those relating to equal opportunity, labor, wage and employment.

§ 3.2 Review of Contract Documents and Field Conditions by Contractor

§ 3.2.1 Execution of the Contract by the Contractor is a representation that the Contractor has visited the site, become generally familiar with local conditions under which the Work is to be performed, and correlated personal observations with requirements of the Contract Documents.

§ 3.2.2 Because the Contract Documents are complementary, the Contractor shall, before starting each portion of the Work, carefully study and compare the various Contract Documents relative to that portion of the Work, as well as the information furnished by the Owner pursuant to Section 2.3.4, shall take field measurements of any existing conditions related to that portion of the Work, and shall observe any conditions at the site affecting it. These obligations are for the purpose of facilitating coordination and construction by the Contractor and are not for the

purpose of discovering errors, omissions, or inconsistencies in the Contract Documents; however, the Contractor shall promptly report to the Architect any errors, inconsistencies or omissions discovered by or made known to the Contractor as a request for information in such form as the Architect may require. It is recognized that the Contractor's review is made in the Contractor's capacity as a contractor and not as a licensed design professional, unless otherwise specifically provided in the Contract Documents. . The exactness of grades, elevations, dimensions, or locations given on any Drawings issued by the Architect, or surveys furnished by the Owner, is not guaranteed by the Architect or the Owner. The Contractor shall, therefore, satisfy itself as to the accuracy of all grades, elevations, dimensions, and locations. Any errors due to the Contractor's failure to so verify all such grades, elevations, dimensions, or locations shall be promptly rectified by the Contractor without any additional cost to the Owner.

§ 3.2.3 Owner assumes no contractual liability or responsibility for the physical condition or safety of the Project site or of any improvement thereon. Except as set forth in Section 10.3, the Contractor shall be solely responsible for providing a safe place for the performance of the Work.

§ 3.2.4 If the Contractor believes that additional cost or time is involved because of clarifications or instructions the Architect issues in response to the Contractor's notices or requests for information pursuant to Sections 3.2.2 or 3.2.3, the Contractor shall submit Claims as provided in Article 15. If the Contractor fails to perform the obligations of Sections 3.2.2 or 3.2.3, the Contractor shall pay such costs and damages to the Owner, subject to Section 15.1.7, as would have been avoided if the Contractor had performed such obligations. If the Contractor performs those obligations, the Contractor shall not be liable to the Owner or Architect for damages resulting from errors, inconsistencies or omissions in the Contract Documents, for differences between field measurements or conditions and the Contract Documents, or for nonconformities of the Contract Documents to applicable laws, statutes, ordinances, codes, rules and regulations, and lawful orders of public authorities.

§ 3.2.5 The Contractor shall give the Architect timely notice of any additional Drawings, Specifications, or instructions required to define the Work in greater detail, or to permit the proper progress of the Work.

§ 3.2.6 The Contractor shall not proceed with any Work not clearly and consistently defined in detail in the Contract Documents, but shall request additional drawings or instructions from the Architect as provided in subparagraph 3.2.5. If the Contractor proceeds with such Work without obtaining further Drawings, Specifications or instructions, the Contractor shall correct Work incorrectly done at the Contractor's own expense.

§ 3.2.7 Except as to any reported errors, inconsistencies or omissions, and as to any concealed or unknown conditions as defined in Paragraph 3.7.4. by executing the Agreement, the Contractor represents the following:

1. The Contract Documents are sufficiently complete and detailed for the Contractor to (1) perform the Work required to produce the results intended by the Contract Documents and (2) comply with all the requirements of the Contract Documents.
2. The Work required by the Contract Documents, including, without limitation, all construction details, construction means, methods, procedures and techniques necessary to perform the Work, use of materials, selection of equipment and requirements of product manufacturers are consistent with: (1) good and sound practices within the construction industry; (2) generally prevailing and accepted industry standards applicable to the Work; and (3) requirements of any warranties applicable to the Work.

§ 3.3 Supervision and Construction Procedures

§ 3.3.1 The Contractor shall supervise and direct the Work, using the Contractor's best skill and attention. The Contractor shall be solely responsible for, and have control over, construction means, methods, techniques, sequences, and procedures, and for coordinating all portions of the Work under the Contract. If the Contract Documents give specific instructions concerning construction means, methods, techniques, sequences, or procedures, the Contractor shall evaluate the jobsite safety thereof and shall be solely responsible for the jobsite safety of such means, methods, techniques, sequences, or procedures. If the Contractor determines that such means, methods, techniques, sequences or procedures may not be safe, the Contractor shall give timely notice to the Owner and Architect, and shall propose alternative means, methods, techniques, sequences, or procedures. The Architect shall evaluate the proposed alternative solely for conformance with the design intent for the completed construction.

Unless the Architect objects to the Contractor's proposed alternative, the Contractor shall perform the Work using its alternative means, methods, techniques, sequences, or procedures.

§ 3.3.2 The Contractor shall be responsible to the Owner for acts and omissions of the Contractor's employees, Subcontractors and their agents and employees, and other persons or entities performing portions of the Work for, or on behalf of, the Contractor or any of its Subcontractors.

§ 3.3.3 The Contractor shall be responsible for inspection of portions of Work already performed to determine that such portions are in proper condition to receive subsequent Work.

§ 3.3.4 The Contractor shall schedule and perform the Work so as not to unreasonably interfere with any other related or unrelated work being performed by the Owner in or about the Project premises or with the Owner's continued use of the Project premises. The Contractor shall protect and prevent damage to all unfinished phases of the Work.

§ 3.4 Labor and Materials

§ 3.4.1 Unless otherwise provided in the Contract Documents, the Contractor shall provide and pay for labor, materials, equipment, tools, construction equipment and machinery, water, heat, utilities, transportation, and other facilities and services necessary for proper execution and completion of the Work, whether temporary or permanent and whether or not incorporated or to be incorporated in the Work.

§ 3.4.2 Except in the case of minor changes in the Work approved by the Architect in accordance with Section 3.12.8 or ordered by the Architect in accordance with Section 7.4, the Contractor may make substitutions only with the consent of the Owner, after evaluation by the Architect and in accordance with a Change Order or Construction Change Directive.

§ 3.4.2.1 Approval by the Owner or Architect of any such substitution shall not relieve the Contractor requesting the substitution of responsibility for any additional costs incurred by other trades for changes made necessary to accommodate the substituted item.

§ 3.4.2.2 By making requests for substitutions based on subparagraph 3.4.2 above, the Contractor:

- .1 represents that the Contractor has personally investigated the proposed substitute product and determined that it is equal or superior in all respects to that specified;
- .2 represents that the Contractor will provide the same warranty for the substitution that the Contractor would for that specified;
- .3 certifies that the cost data presented is complete and includes all related costs under this Contract except the Architect's redesign costs, and waives all claims for additional costs related to substitution which subsequently become apparent; and
- .4 shall coordinate the installation of the accepted substitution, making such changes as may be required for the Work to be complete in all respects.

§ 3.4.3 The Contractor shall enforce strict discipline and good order among the Contractor's employees and other persons carrying out the Work. The Contractor shall not permit employment of unfit persons or persons not properly skilled in tasks assigned to them.

§ 3.4.4 The Contractor shall be responsible for determining that all materials furnished for the Work meet all requirements of the Contract Documents. The Architect may require the Contractor to produce reasonable evidence that a material meets such requirements, such as certified reports of past tests by qualified testing laboratories, reports of studies by qualified experts, or other evidence which, in the opinion of the Architect, would lead to a reasonable certainty that any material used, or proposed to be used, in the Work meets the requirements of the Contract Documents. All such data shall be furnished at the Contractor's expense.

§ 3.4.5 In all cases in which a manufacturer's name, trade name or other proprietary designation is used in connection with materials or articles to be furnished under this Contract, the Contractor shall furnish the product of the named manufacturer(s) without substitution.

§ 3.4.6 The Contractor shall only employ or use labor in connection with the Work capable of working harmoniously with all trades, crafts, and any other individuals associated with the Project. The Contractor shall also use best efforts to minimize the likelihood of any strike, work stoppage, or other labor disturbance.

§ 3.5 Warranty

§ 3.5.1 The Contractor warrants to the Owner and Architect that materials and equipment furnished under the Contract will be of good quality and new unless the Contract Documents require or permit otherwise. The Contractor further warrants that the Work will conform to the requirements of the Contract Documents and will be free from defects, except for those inherent in the quality of the Work the Contract Documents require or permit. Work, materials, or equipment not conforming to these requirements may be considered defective. The Contractor's warranty excludes remedy for damage or defect caused by abuse, alterations to the Work not executed by the Contractor, improper or insufficient maintenance, improper operation, or normal wear and tear and normal usage. If required by the Architect, the Contractor shall furnish satisfactory evidence as to the kind and quality of materials and equipment.

§ 3.5.2 All material, equipment, or other special warranties required by the Contract Documents shall be issued in the name of the Owner, or shall be transferable to the Owner, and shall commence in accordance with Section 9.8.4.

§ 3.5.2 Contractor agrees to assign to the Owner as a condition precedent to Substantial Completion of the Work any and all manufacturer's warranties relating to materials and equipment installed in the Work and further agrees to perform the Work in such manner so as to preserve any and all such manufacturer's warranties.

§ 3.5.3 The warranty provided in this Paragraph 3.5 shall be in addition to and not in limitation of any other warranty or guaranty required by the Contract Documents or otherwise prescribed by law.

§ 3.6 Taxes

The Owner is a tax-exempt entity. The Contractor shall be familiar with the current regulations of the Connecticut Department of Revenue Services and the sales or use tax on materials or supplies exempted by such regulations shall not be included as part of the bid or the Contract Sum. A sales tax certificate is available upon written request.

§ 3.7 Permits, Fees, Notices and Compliance with Laws

§ 3.7.1 Unless otherwise provided in the Contract Documents, the Contractor shall secure the building permit as well as for other permits, fees, licenses, and inspections by government agencies necessary for proper execution and completion of the Work, including, without limitation, all building permits, subsidiary trade permits, and occupancy permits. All inspection fees as may be imposed by any municipal agency are included in the Contract Sum and shall be the Contractor's responsibility.

§ 3.7.1.1 The "Agencies" are the Department of Education of the State of Connecticut (the "Department"), and all other governmental authorities having regulatory or administrative jurisdiction over the Work and/or Project and all representatives or designees of the Department or such other governmental authorities. The term "Agencies" shall also include an individuals or entities designated by the Department or such other governmental authorities or by the Owner to monitor or oversee compliance of the Project's energy and environmental design with the requirements of the Department or such other governmental authorities.

§ 3.7.1.2 The term "Agencies" shall also include an individual or entity not described in Section 3.7.1.1 from whom the Owner intends to request certification of the Project's energy and environmental design, to the extent included in the Contract Documents.

§ 3.7.2 The Contractor shall comply with and give notices required by applicable laws, statutes, ordinances, codes, rules and regulations, and lawful orders of public authorities applicable to performance of the Work. The Contractor shall procure and obtain all bonds required of the Owner or the Contractor by the municipality in which the Project is located or any public or private body with jurisdiction over the Project. In connection with such bonds, the Contractor shall prepare all applications, supply all necessary backup material, and furnish the surety with any required personal undertakings. The Owner will pay the price of all such bond premiums.

§ 3.7.3

If the Contractor performs Work which it knows or should know is contrary to applicable laws, statutes, ordinances, codes, rules and regulations, or lawful orders of public authorities, the Contractor shall assume appropriate responsibility for such Work and shall bear the costs attributable to correction.

§ 3.7.4 Concealed or Unknown Conditions

If the Contractor encounters conditions at the site that are (1) subsurface or otherwise concealed physical conditions that differ materially from those indicated in the Contract Documents or (2) unknown physical conditions of an unusual nature that differ materially from those ordinarily found to exist and generally recognized as inherent in construction activities of the character provided for in the Contract Documents, the Contractor shall promptly provide notice to the Owner and the Architect before conditions are disturbed and in no event later than 14 days after first observance of the conditions. The Architect will promptly investigate such conditions and, if the Architect determines that they differ materially and cause an increase or decrease in the Contractor's cost of, or time required for, performance of any part of the Work, will recommend that an equitable adjustment be made in the Contract Sum or Contract Time, or both. If the Architect determines that the conditions at the site are not materially different from those indicated in the Contract Documents and that no change in the terms of the Contract is justified, the Architect shall promptly notify the Owner and Contractor, stating the reasons. If either party disputes the Architect's determination or recommendation, that party may submit a Claim as provided in Article 15.

§ 3.7.5 If, in the course of the Work, the Contractor encounters human remains or recognizes the existence of burial markers, archaeological sites or wetlands not indicated in the Contract Documents, the Contractor shall immediately suspend any operations that would affect them and shall notify the Owner and Architect. Upon receipt of such notice, the Owner shall promptly take any action necessary to obtain governmental authorization required to resume the operations. The Contractor shall continue to suspend such operations until otherwise instructed by the Owner but shall continue with all other operations that do not affect those remains or features. Requests for adjustments in the Contract Sum and Contract Time arising from the existence of such remains or features may be made as provided in Article 15.

§ 3.7.6 If any governmental body having jurisdiction over the Work requires licenses or registrations for the performance of the Work or any part thereof, the Contractor shall hold such valid licenses or registrations as may be required by law to prosecute the Work to completion. If any part of the Work for which such a license or registration is required is to be performed by Subcontractors of any tier, the Contractor shall ensure that such Subcontractors hold such valid licenses or registrations as may be required by law to prosecute said Work to completion.

§ 3.8 Allowances

§ 3.8.1 The Contractor shall include in the Contract Sum all allowances stated in the Contract Documents. Items covered by allowances shall be supplied for such amounts and by such persons or entities as the Owner may direct, but the Contractor shall not be required to employ persons or entities to whom the Contractor has reasonable objection.

§ 3.8.2 Unless otherwise provided in the Contract Documents,

- .1 allowances shall cover the cost to the Contractor of materials and equipment delivered at the site and all required taxes, less applicable trade discounts;
- .2 Contractor's costs for unloading and handling at the site, labor, installation costs, overhead, profit, and other expenses contemplated for stated allowance amounts shall be included in the Contract Sum but not in the allowances; and
- .3 whenever costs are more than or less than allowances, the Contract Sum shall be adjusted accordingly by Change Order. The amount of the Change Order shall reflect (1) the difference between actual costs and the allowances under Section 3.8.2.1 and (2) changes in Contractor's costs under Section 3.8.2.2.

§ 3.8.3 Materials and equipment under an allowance shall be selected by the Owner with reasonable promptness.

§ 3.9 Superintendent

§ 3.9.1 The Contractor shall employ a competent superintendent and necessary assistants who shall be in attendance at the Project site during performance of the Work. The superintendent shall represent the Contractor, and communications given to the superintendent shall be as binding as if given to the Contractor.

§ 3.9.2 The Contractor, as soon as practicable after award of the Contract, shall notify the Owner and Architect of the name and qualifications of a proposed superintendent. Within 14 days of receipt of the information, the Architect may notify the Contractor, stating whether the Owner or the Architect (1) has reasonable objection to the proposed superintendent or (2) requires additional time for review. Failure of the Owner or Architect to provide notice within the 14-day period shall constitute notice of no reasonable objection.

§ 3.9.3 The Contractor shall not employ a proposed superintendent to whom the Owner or Architect has made reasonable objection. The Contractor shall not change the superintendent without the Owner's consent, which shall not unreasonably be withheld or delayed.

§ 3.9.4 The Contractor shall coordinate and supervise the Work performed by Subcontractors to the end that the Work is carried out without conflict between trades and so that no trade, at any time, causes delay to the general progress of the Work. The Contractor and all Subcontractors shall at all times afford each trade, any separate contractor, or the Owner, every reasonable opportunity for the installation of Work and the storage of materials.

§ 3.9.5 Contractor shall at all times enforce strict discipline and good order among its employees (and those of its Subcontractors) and shall not employ on the Work any unfit person or anyone not skilled in the task assigned to them. All labor shall be performed by workmen skilled in their respective trades and workmanship shall be of good quality in accordance with the standards of construction set forth in the Contract Documents.

§ 3.10 Contractor's Construction and Submittal Schedules

§ 3.10.1 The Contractor, promptly after being awarded the Contract, shall submit for the Owner's and Architect's information a Contractor's construction schedule for the Work. The schedule shall contain detail appropriate for the Project, including (1) the date of commencement of the Work, interim schedule milestone dates, and the date of Substantial Completion; (2) an apportionment of the Work by construction activity; and (3) the time required for completion of each portion of the Work. The schedule shall provide for the orderly progression of the Work to completion and shall not exceed time limits current under the Contract Documents. The schedule shall be revised at appropriate intervals as required by the conditions of the Work and Project.

§ 3.10.2 The Contractor, promptly after being awarded the Contract and thereafter as necessary to maintain a current submittal schedule, shall submit a submittal schedule for the Architect's approval. The Architect's approval shall not be unreasonably delayed or withheld. The submittal schedule shall (1) be coordinated with the Contractor's construction schedule, and (2) allow the Architect reasonable time to review submittals. If the Contractor fails to submit a submittal schedule, or fails to provide submittals in accordance with the approved submittal schedule, the Contractor shall not be entitled to any increase in Contract Sum or extension of Contract Time based on the time required for review of submittals.

§ 3.10.3 The Contractor shall perform the Work in general accordance with the most recent schedules submitted to the Owner and Architect.

§ 3.10.4 The construction schedule shall be in a detailed precedence-style critical path management ("CPM") format satisfactory to the Owner and the Architect that shall also (i) provide a graphic representation of all activities and events that will occur during performance of the Work; (ii) identify each phase of construction and occupancy; and (iii) set forth dates that are critical in ensuring the timely and orderly completion of the Work in accordance with the requirements of the Contract Documents (hereinafter referred to as "Milestone Dates"). Upon review and acceptance by the Owner and the Architect of the Milestone Dates, the construction schedule shall be deemed part of the Contract Documents. If not accepted, the construction schedule shall be promptly revised by the Contractor in accordance with the recommendations of the Owner and the Architect and resubmitted for acceptance. The Contractor shall monitor the progress of the Work for conformance with the requirements of the construction schedule and shall promptly advise the Owner of any delays or potential delays. The accepted construction schedule shall be updated to reflect actual conditions, as set forth in Subparagraph 3.10.1 or if requested by either the Owner

or the Architect. In the event any progress report indicates any delays, the Contractor shall propose an affirmative plan to correct the delay, including overtime and/or additional labor, if necessary. In no event shall any progress report constitute an adjustment in the Contract Time, any Milestone Date, or the Contract Sum unless any such adjustment is agreed to by the Owner and authorized pursuant to Change Order.

§ 3.10.5 In the event the Owner determines that the performance of the Work, as of a Milestone Date, has not progressed or reached the level of completion required by the Contract Documents, the Owner shall have the right to order the Contractor to take corrective measures necessary to expedite the progress of construction, including, without limitation, (i) working additional shifts or overtime, (ii) supplying additional manpower, equipment, and facilities, and (iii) other similar measures (hereinafter referred to collectively as “Extraordinary Measures”). Such Extraordinary Measures shall continue until the progress of the Work complies with the stage of completion required by the Contract Documents. The Owner’s right to require Extraordinary Measures is solely for the purpose of ensuring the Contractor’s compliance with the construction schedule.

1. The Contractor shall not be entitled to an adjustment in the Contract Sum in connection with Extraordinary Measures required by the Owner under or pursuant to this Subparagraph 3.10.5.
2. The Owner may exercise the rights furnished the Owner under or pursuant to this Subparagraph 3.10.5 as frequently as the Owner deems necessary to ensure that the Contractor’s performance of the Work will comply with the completion date set forth in the Contract Documents.

§ 3.10.6 The Owner shall have the right to direct a postponement or rescheduling of any date or time for the performance of any part of the Work that may interfere with the operation of the Owner’s premises or any invitees thereof. The Contractor shall, upon the Owner’s request, reschedule any portion of the Work affecting operation of the premises during hours when the premises are in operation. Any postponement or rescheduling under Subparagraph 3.10.5. may be grounds for an extension of the Contract Time if permitted under Subparagraph 8.3.1.

§ 3.11 Documents and Samples at the Site

The Contractor shall make available, at the Project site, the Contract Documents, including Change Orders, Construction Change Directives, and other Modifications, in good order and marked currently to indicate field changes and selections made during construction, and the approved Shop Drawings, Product Data, Samples, and similar required submittals. These shall be in electronic form or paper copy, available to the Architect and Owner, and delivered to the Architect for submittal to the Owner upon completion of the Work as a record of the Work as constructed.

§ 3.12 Shop Drawings, Product Data and Samples

§ 3.12.1 Shop Drawings are drawings, diagrams, schedules, and other data specially prepared for the Work by the Contractor or a Subcontractor, Sub-subcontractor, manufacturer, supplier, or distributor to illustrate some portion of the Work.

§ 3.12.2 Product Data are illustrations, standard schedules, performance charts, instructions, brochures, diagrams, and other information furnished by the Contractor to illustrate materials or equipment for some portion of the Work.

§ 3.12.3 Samples are physical examples that illustrate materials, equipment, or workmanship, and establish standards by which the Work will be judged.

§ 3.12.4 Shop Drawings, Product Data, Samples, and similar submittals are not Contract Documents. Their purpose is to demonstrate how the Contractor proposes to conform to the information given and the design concept expressed in the Contract Documents for those portions of the Work for which the Contract Documents require submittals. Review by the Architect is subject to the limitations of Section 4.2.7. Informational submittals upon which the Architect is not expected to take responsive action may be so identified in the Contract Documents. Submittals that are not required by the Contract Documents may be returned by the Architect without action.

§ 3.12.5 The Contractor shall review for compliance with the Contract Documents, approve, and submit to the Architect, Shop Drawings, Product Data, Samples, and similar submittals required by the Contract Documents, in accordance with the submittal schedule approved by the Architect or, in the absence of an approved submittal

schedule, with reasonable promptness and in such sequence as to cause no delay in the Work or in the activities of the Owner or of Separate Contractors.

§ 3.12.6 By submitting Shop Drawings, Product Data, Samples, and similar submittals, the Contractor represents to the Owner and Architect that the Contractor has (1) reviewed and approved them, (2) determined and verified materials, field measurements and field construction criteria related thereto, or will do so, and (3) checked and coordinated the information contained within such submittals with the requirements of the Work and of the Contract Documents. The Contractor shall indicate approval on the submittals as evidence of such review and coordinate submittals made to the Architect without such indications of approval may be returned to the Contractor for resubmission.

§ 3.12.7 The Contractor shall perform no portion of the Work for which the Contract Documents require submittal and review of Shop Drawings, Product Data, Samples, or similar submittals, until the respective submittal has been approved by the Architect.

§ 3.12.8 The Work shall be in accordance with approved submittals except that the Contractor shall not be relieved of responsibility for deviations from the requirements of the Contract Documents by the Architect's approval of Shop Drawings, Product Data, Samples, or similar submittals, unless the Contractor has specifically notified the Architect of such deviation at the time of submittal and (1) the Architect has given written approval to the specific deviation as a minor change in the Work, or (2) a Change Order or Construction Change Directive has been issued authorizing the deviation. The Contractor shall not be relieved of responsibility for errors or omissions in Shop Drawings, Product Data, Samples, or similar submittals, by the Architect's approval thereof.

§ 3.12.9 The Contractor shall direct specific attention, in writing or on resubmitted Shop Drawings, Product Data, Samples, or similar submittals, to revisions other than those requested by the Architect on previous submittals. In the absence of such notice, the Architect's approval of a resubmission shall not apply to such revisions.

§ 3.12.10 The Contractor shall not be required to provide professional services that constitute the practice of architecture or engineering unless such services are specifically required by the Contract Documents for a portion of the Work or unless the Contractor needs to provide such services in order to carry out the Contractor's responsibilities for construction means, methods, techniques, sequences, and procedures. The Contractor shall not be required to provide professional services in violation of applicable law.

§ 3.12.10.1 If professional design services or certifications by a design professional related to systems, materials, or equipment are specifically required of the Contractor by the Contract Documents, the Owner and the Architect will specify all performance and design criteria that such services must satisfy. The Contractor shall be entitled to rely upon the adequacy and accuracy of the performance and design criteria provided in the Contract Documents. The Contractor shall cause such services or certifications to be provided by an appropriately licensed design professional, whose signature and seal shall appear on all drawings, calculations, specifications, certifications, Shop Drawings, and other submittals prepared by such professional. Shop Drawings, and other submittals related to the Work, designed or certified by such professional, if prepared by others, shall bear such professional's written approval when submitted to the Architect. The Owner shall be entitled to rely upon the adequacy and accuracy of the services, certifications, and approvals performed or provided by such design professionals, provided the Owner and Architect have specified to the Contractor the performance and design criteria that such services must satisfy. Pursuant to this Section 3.12.10, the Architect will review and approve or take other appropriate action on submittals only for the limited purpose of checking for conformance with information given and the design concept expressed in the Contract Documents.

§ 3.12.10.2 If the Contract Documents require the Contractor's design professional to certify that the Work has been performed in accordance with the design criteria, the Contractor shall furnish such certifications to the Architect at the time and in the form specified by the Architect.

§ 3.13 Use of Site

§ 3.13.1 The Contractor shall confine operations at the site to areas permitted by applicable laws, statutes, ordinances, codes, rules and regulations, lawful orders of public authorities, and the Contract Documents and shall not unreasonably encumber the site with materials or equipment.

§ 3.13.2 Only materials and equipment that are to be used directly in the Work shall be brought to and stored on the Project site by the Contractor. After equipment is no longer required for the Work, it shall be promptly removed from the Project site. Protection of construction materials and equipment stored at the Project site from weather, theft, damage, and all other adversity is solely the responsibility of the Contractor. The Contractor shall ensure that the Work, at all times, is performed in a manner that affords reasonable access, both vehicular and pedestrian, to the site of the Work and all adjacent areas. The Work shall be performed, to the fullest extent reasonably possible, in such a manner that occupied areas adjacent to the site of the Work shall at all time remain free from all debris and building materials.

§ 3.13.3 Other than those reasonably required for safety purposes, the Contractor and any entity for whom the Contractor is responsible shall not erect any sign on the Project site without the prior written consent of the Owner, which may be withheld in the sole discretion of the Owner.

§ 3.13.4 Without limitation of any other provision of the Contract Documents, the Contractor shall use best efforts to minimize any interference with the occupancy or beneficial use of any areas and buildings adjacent to the site of the Work. Without prior approval of the Owner, the Contractor shall not permit any workers to use any existing facilities at the Project site, including, without limitation, lavatories, toilets, entrances, and parking areas other than those designated by the Owner.

§ 3.14 Cutting and Patching

§ 3.14.1 The Contractor shall be responsible for cutting, fitting, or patching required to complete the Work or to make its parts fit together properly. All areas requiring cutting, fitting, or patching shall be restored to the condition existing prior to the cutting, fitting, or patching, unless otherwise required by the Contract Documents.

§ 3.14.2 The Contractor shall not damage or endanger a portion of the Work or fully or partially completed construction of the Owner or Separate Contractors by cutting, patching, or otherwise altering such construction, or by excavation. The Contractor shall not cut or otherwise alter construction by the Owner or a Separate Contractor except with written consent of the Owner and of the Separate Contractor. Consent shall not be unreasonably withheld. The Contractor shall not unreasonably withhold, from the Owner or a Separate Contractor, its consent to cutting or otherwise altering the Work.

§ 3.15 Cleaning Up

§ 3.15.1 The Contractor shall keep the premises and surrounding area free from accumulation of waste materials and rubbish caused by operations under the Contract. At completion of the Work, the Contractor shall remove waste materials, rubbish, the Contractor's tools, construction equipment, machinery, and surplus materials from and about the Project and shall clean and/or remove all stains, spots, work, blemishes, foreign matter and dirt from other surfaces not part of the Work but where such conditions resulted from the Contractor's operations.

§ 3.15.2 If the Contractor fails to clean up as provided in the Contract Documents, the Owner may do so and the Owner shall be entitled to reimbursement from the Contractor for the full cost of such cleanup.

§ 3.16 Access to Work

The Contractor shall provide the Owner and Architect with access to the Work in preparation and progress wherever located.

§ 3.17 Royalties, Patents and Copyrights

The Contractor shall pay all royalties and license fees. The Contractor shall defend suits or claims for infringement of copyrights and patent rights and shall hold the Owner and Architect harmless from loss on account thereof, but shall not be responsible for defense or loss when a particular design, process, or product of a particular manufacturer or manufacturers is required by the Contract Documents, or where the copyright violations are contained in Drawings, Specifications, or other documents prepared by the Owner or Architect. However, if an infringement of a copyright or patent is discovered by, or made known to, the Contractor, the Contractor shall be responsible for the loss unless the information is promptly furnished to the Architect.

§ 3.18 Indemnification

§ 3.18.1 To the fullest extent permitted by law, the Contractor shall indemnify and hold harmless the Owner, Architect, Architect's consultants, and agents and employees of any of them from and against claims, damages, losses, and expenses, including but not limited to attorneys' fees, arising out of or resulting from performance of the Work, provided that such claim, damage, loss, or expense is attributable to bodily injury, sickness, disease or death, or to injury to or destruction of tangible property (other than the Work itself), but only to the extent caused by the negligent acts or omissions of the Contractor, a Subcontractor, anyone directly or indirectly employed by them, or anyone for whose acts they may be liable, regardless of whether or not such claim, damage, loss, or expense is caused in part by a party indemnified hereunder. Such obligation shall not be construed to negate, abridge, or reduce other rights or obligations of indemnity that would otherwise exist as to a party or person described in this Section 3.18.

§ 3.18.2 The Contractor's indemnity obligations under this Paragraph 3.18 shall also specifically include, without limitation, all fines, penalties, damages, liability, costs, expenses (including, without limitation, reasonable attorneys' fees), and punitive damages (if any) arising out of, or in connection with, any (i) violation of or failure to comply with any law, statute, ordinance, rule, regulation, code, or requirement of a public authority that bears upon the performance of the Work by the Contractor, a Subcontractor, or any person or entity for whom either is responsible, (ii) means, methods, procedures, techniques, or sequences of execution or performance of the Work, and (iii) failure to secure and pay for permits, fees, approvals, licenses, and inspections as required under the Contract Documents, or any violation of any permit or other approval of a public authority applicable to the Work, by the Contractor, a Subcontractor, or any person or entity for whom either is responsible.

§ 3.18.3 The Contractor shall indemnify, defend and hold harmless the Owner against any and all mechanic's liens placed on the premises or on Owner's interest in the premises by any Subcontractor of any tier or material supplier. In the event that a Subcontractor of any tier or material supplier places a mechanic's lien on the premises, the Contractor shall, with thirty (30) days of the filing of any mechanic's lien, substitute a bond for such lien or cause the lien to be discharged. If the Contractor shall fail to do so, the Owner may, at its option and at the expense of the Contractor, bond such lien or cause the lien to be discharged, and the Contractor will reimburse the Owner for all costs and expenses incurred, including but not limited to attorneys' fees and court costs.

§ 3.18.4 The Contractor shall indemnify, defend, and hold harmless the Owner from and against any additional costs or expenses incurred by Owner, including attorneys' fees and court costs, as a result of any claim or cause of action by any Subcontractor or supplier of any tier asserted directly against the Owner to recover payment for labor or materials supplied to the Project, unless such claim or cause of action arises from the failure of the Owner to make payments in accordance with the applicable provisions of the Contract Documents.

§ 3.18.5 The Contractor shall indemnify and hold harmless the Owner, its agents and employees from and against any costs and expenses, including attorneys' fees and court costs, incurred in enforcing any of the Contractor's defense, indemnity, and hold harmless obligations under this Contract.

§ 3.18.6 The Contractor, for itself, its insurers and all subcontractors and their insurers, shall waive governmental immunity as a defense and shall not use the defense of governmental immunity in the adjustment of claims or in the defense of any suit, action or claim brought against the Owner. Nothing herein shall limit the Owner from utilizing the defense of governmental immunity.

§ 3.19 MEETINGS

The Contractor shall send a qualified representative to periodic progress meetings held at such time and at such place as the Architect or the Owner shall designate in accordance with the Contract Documents and to such other meetings as are necessary to comply with the Conditions.

ARTICLE 4 ARCHITECT

§ 4.1 General

§ 4.1.1 The Architect is the person or entity retained by the Owner pursuant to Section 2.3.2 and identified as such in the Agreement.

§ 4.1.2 Duties, responsibilities, and limitations of authority of the Architect as set forth in the Contract Documents shall not be restricted, modified, or extended without written consent of the Owner, Contractor, and Architect. Consent shall not be unreasonably withheld.

§ 4.2 Administration of the Contract

§ 4.2.1 The Architect will provide administration of the Contract as described in the Contract Documents and will be an Owner's representative during construction, (i) until the final payment is due, (ii) from time to time during the one year period described in Section 12.2, (iii) while review or certification of the Project from any of the Agencies is pending and (iv) while any audit by the Department is ongoing. The Architect will have authority to act on behalf of the Owner only to the extent specified in the Contract Documents.

§ 4.2.2 The Architect will visit the site at intervals appropriate to the stage of construction, or as otherwise agreed with the Owner, to become generally familiar with the progress and quality of the portion of the Work completed, and to determine in general if the Work observed is being performed in a manner indicating that the Work, when fully completed, will be in accordance with the Contract Documents. However, the Architect will not be required to make exhaustive or continuous on-site inspections to check the quality or quantity of the Work. The Architect will not have control over, charge of, or responsibility for the construction means, methods, techniques, sequences or procedures, or for the safety precautions and programs in connection with the Work, since these are solely the Contractor's rights and responsibilities under the Contract Documents.

§ 4.2.3 On the basis of the site visits, the Architect will keep the Owner reasonably informed about the progress and quality of the portion of the Work completed, and promptly report to the Owner (1) known deviations from the Contract Documents, (2) known deviations from the most recent construction schedule submitted by the Contractor, and (3) defects and deficiencies observed in the Work. The Architect will not be responsible for the Contractor's failure to perform the Work in accordance with the requirements of the Contract Documents. The Architect will not have control over or charge of, and will not be responsible for acts or omissions of, the Contractor, Subcontractors, or their agents or employees, or any other persons or entities performing portions of the Work.

§ 4.2.4 Communications

The Owner and Contractor shall include the Architect in all communications that relate to or affect the Architect's services or professional responsibilities. The Owner shall promptly notify the Architect of the substance of any direct communications between the Owner and the Contractor otherwise relating to the Project. Communications by and with the Architect's consultants shall be through the Architect. Communications by and with Subcontractors and suppliers shall be through the Contractor. Communications by and with Separate Contractors shall be through the Owner. The Contract Documents may specify other communication protocols.

§ 4.2.5 Based on the Architect's evaluations of the Contractor's Applications for Payment, the Architect will review and certify the amounts due the Contractor and will issue Certificates for Payment in such amounts.

§ 4.2.6 The Architect has authority to reject Work that does not conform to the Contract Documents. Whenever the Architect considers it necessary or advisable, the Architect will have authority to require inspection or testing of the Work in accordance with Sections 13.4.2 through 13.4.4, whether or not the Work is fabricated, installed or completed.

§ 4.2.7 The Architect will review and approve, or take other appropriate action upon, the Contractor's submittals such as Shop Drawings, Product Data, and Samples, but only for the limited purpose of assuring conformity with information given and the design concept expressed in the Contract Documents. The Architect's action will be taken in accordance with the submittal schedule approved by the Architect or, in the absence of an approved submittal schedule, with reasonable promptness while allowing sufficient time in the Architect's professional judgment to permit adequate review. Review of such submittals is not conducted for the purpose of determining the accuracy and completeness of other details such as dimensions and quantities, or for substantiating instructions for installation or performance of equipment or systems, all of which remain the responsibility of the Contractor as required by the Contract Documents. The Architect's review of the Contractor's submittals shall not relieve the Contractor of the obligations under Sections 3.3, 3.5, and 3.12. The Architect's review shall not constitute approval of safety precautions or of any construction means, methods, techniques, sequences, or procedures. The Architect's approval of a specific item shall not indicate approval of an assembly of which the item is a component.

§ 4.2.8 The Architect will prepare Change Orders and Construction Change Directives, and may order minor changes in the Work as provided in Section 7.4. The Architect will investigate and make determinations and recommendations regarding concealed and unknown conditions as provided in Section 3.7.4.

§ 4.2.9 The Architect will conduct inspections to determine the date or dates of Substantial Completion and the date of final completion; issue Certificates of Substantial Completion pursuant to Section 9.8; receive and forward to the Owner, for the Owner's review and records, written warranties and related documents required by the Contract Documents and assembled by the Contractor pursuant to Section 9.10; and issue a final Certificate for Payment pursuant to Section 9.10.

§ 4.2.10 The Architect will provide one or more Project representatives to assist in carrying out the Architect's responsibilities at the site. The Owner shall notify the Contractor of any change in the duties, responsibilities and limitations of authority of the Project representatives.

§ 4.2.11 The Architect will interpret and decide matters concerning performance under, and requirements of, the Contract Documents on written request of either the Owner or Contractor. The Architect's response to such requests will be made in writing within any time limits agreed upon or otherwise with reasonable promptness.

§ 4.2.12 Interpretations and decisions of the Architect will be consistent with the intent of, and reasonably inferable from, the Contract Documents and will be in writing or in the form of drawings. When making such interpretations and decisions, the Architect will endeavor to secure faithful performance by both Owner and Contractor, will not show partiality to either, and will not be liable for results of these interpretations or decisions rendered in good faith which were necessitated by a reason other than an act or omission of the Architect.

§ 4.2.13 The Architect's decisions on matters relating to aesthetic effect will be final if consistent with the intent expressed in the Contract Documents.

§ 4.2.14 The Architect will review and respond to requests for information about the Contract Documents. The Architect's response to such requests will be made in writing within any time limits agreed upon or otherwise with reasonable promptness. Requests for information shall include, at a minimum, a detailed written statement that indicates the specific element of the Contract Documents in need of clarification and the nature of the clarification requested. If appropriate, the Architect will prepare and issue supplemental Drawings and Specifications in response to the requests for information.

§ 4.2.15 Each Subcontract executed by the Contractor shall include language that instructs the Subcontractor that the Subcontractor is to submit written information requests regarding Contract Document interpretation only to the Contractor and not the Architect. The Contractor shall timely review each such information request and only as necessary, submit to the Architect any information request that in the Contractor's professional judgment is not clearly and unambiguously answered in the Contract Documents.

ARTICLE 5 SUBCONTRACTORS

§ 5.1 Definitions

§ 5.1.1 A Subcontractor is a person or entity who has a direct contract with the Contractor to perform a portion of the Work at the site. The term "Subcontractor" is referred to throughout the Contract Documents as if singular in number and means a Subcontractor or an authorized representative of the Subcontractor. The term "Subcontractor" does not include a Separate Contractor or the subcontractors of a Separate Contractor.

§ 5.1.2 A Sub-subcontractor is a person or entity who has a direct or indirect contract with a Subcontractor to perform a portion of the Work at the site. The term "Sub-subcontractor" is referred to throughout the Contract Documents as if singular in number and means a Sub-subcontractor or an authorized representative of the Sub-subcontractor.

§ 5.2 Award of Subcontracts and Other Contracts for Portions of the Work

§ 5.2.1 Unless otherwise stated in the Contract Documents, the Contractor, as soon as practicable after award of the Contract, shall notify the Owner and Architect of the persons or entities proposed for each principal portion of the Work, including those who are to furnish materials or equipment fabricated to a special design. Within 14 days of

receipt of the information, the Owner or Architect may notify the Contractor whether the Owner or the Architect (1) has reasonable objection to any such proposed person or entity or (2) either requires additional time for review. Failure of the Architect to provide notice within the 14-day period shall constitute notice of no reasonable objection.

§ 5.2.1.1 To facilitate and expedite the investigations of such proposed persons or entities the Contractor shall submit a statement in writing in sufficient detail to establish that each has the capacity to carry out the portion of the Work such person or entity is proposing to provide. All such submittals shall include a list of principal personnel of any such entity, and an analysis of the financial condition, construction plant, equipment and facilities of any such person or entity. The Contractor shall terminate any contract with a person or entity to whom the Owner has a reasonable objection if such proposed and rejected subcontractor or such terminated.

§ 5.2.2 The Contractor shall not contract with a proposed person or entity to whom the Owner or Architect has made reasonable and timely objection. The Contractor shall not be required to contract with anyone to whom the Contractor has made reasonable objection.

§ 5.2.3 If the Owner or Architect has reasonable objection to a person or entity proposed by the Contractor, the Contractor shall propose another to whom the Owner or Architect has no reasonable objection. If the proposed but rejected Subcontractor was reasonably capable of performing the Work, the Contract Sum and Contract Time shall be increased or decreased by the difference, if any, occasioned by such change, and an appropriate Change Order shall be issued before commencement of the substitute Subcontractor's Work. However, no increase in the Contract Sum or Contract Time shall be allowed for such change unless the Contractor has acted promptly and responsively in submitting names as required.

§ 5.2.4 If the Contractor wishes to substitute a Subcontractor, person, or entity for one previously selected, the parties shall follow the procedures outlined in Section 5.2.1.

§ 5.3 Subcontractual Relations

§ 5.3.1 Any part of the Work performed for the Contractor by a Subcontractor shall be pursuant to a written Subcontract between the Contractor and Subcontractor, which shall be prepared on a form of Subcontract reasonably satisfactory to the Owner in all respects. The Owner shall be a third party beneficiary of all contracts between the Contractor and Subcontractor and all such contracts shall require that the Owner be a third party beneficiary of all contracts between Subcontractors and Sub-Subcontractors. Copies of all Subcontractor bids or proposals shall, upon request of Owner, be submitted to the Owner and Architect.

§ 5.3.2 By appropriate agreement, written where legally required for validity, the Contractor shall require each Subcontractor, to the extent of the Work to be performed by the Subcontractor, to be bound to the Contractor by terms of the Contract Documents, and to assume toward the Contractor all the obligations and responsibilities, including the responsibility for safety of the Subcontractor's Work, which the Contractor, by these Documents, assumes toward the Owner and Architect. Each subcontract agreement shall preserve and protect the rights of the Owner and Architect under the Contract Documents with respect to the Work to be performed by the Subcontractor so that subcontracting thereof will not prejudice such rights, and shall allow to the Subcontractor, unless specifically provided otherwise in the subcontract agreement, the benefit of all rights, remedies and remedies against the Contractor that the Contractor, by the Contract Documents, has against the Owner. Where appropriate, the Contractor shall require each Subcontractor to enter into similar agreements with Sub-subcontractors. The Contractor shall make available to each proposed Subcontractor, prior to the execution of the subcontract agreement, copies of the Contract Documents to which the Subcontractor will be bound, and, upon written request of the Subcontractor, identify to the Subcontractor terms and conditions of the proposed subcontract agreement that may be at variance with the Contract Documents. Subcontractors will similarly make copies of applicable portions of such documents available to their respective proposed Sub-subcontractors.

§ 5.3.3 The Contractor shall be fully responsible for coordinating and expediting the work of all Subcontractors, and shall employ the necessary and qualified personnel to produce the required quality of labor and materials and to prevent delays in the progress of the Project. The Contractor shall afford each trade with all reasonable opportunities for the installation of its work and for the storage and handling of its materials. The Contractors shall include in the Contractor's bid, any work, in connection with the mechanical trades, to be done by other trades under the Contractor's direct control.

§ 5.3.4 Within thirty (30) calendar days after payment to Contractor by the Owner, the Contractor shall pay any amounts due any Subcontractor, whether for labor performed or materials furnished when such labor or material has been included in requisition submitted by such Contractor and paid by Owner. The Contractor shall promptly give notice to the Owner of any claim or demand by a Subcontractor claiming that any amount is due to such Subcontractor or claiming any default by the Contractor in any of the Contractor's obligations to such Subcontractor.

§ 5.3.5 The Contractor shall include in each of the subcontracts a provision requiring each Subcontractor to pay amounts due to any Sub-Subcontractors, whether for labor performed or materials furnished, within thirty (30) days after such Subcontractor receives a payment from the Contractor which encompasses labor or materials furnished by such Sub-subcontractor and a provision requiring each Subcontractor to promptly any claim or demand by a Sub-subcontractor claiming that any amount is due to such Sub-Subcontractor or claiming any default by such Subcontractor in any of its obligations to such Sub-subcontractor which notice the Contractor shall promptly relay to the Owner.

§ 5.4 Contingent Assignment of Subcontracts

§ 5.4.1 Each subcontract agreement for a portion of the Work is assigned by the Contractor to the Owner, provided that

- .1 assignment is effective only after termination of the Contract by the Owner for cause pursuant to Section 14.2 and only for those subcontract agreements that the Owner accepts by notifying the Subcontractor and Contractor; and
- .2 assignment is subject to the prior rights of the surety, if any, obligated under bond relating to the Contract.

When the Owner accepts the assignment of a subcontract agreement, the Owner assumes the Contractor's rights and obligations under the subcontract.. The Contractor agrees to execute any and all other documents required to effect this assignment.

§ 5.4.2 Upon such assignment, if the Work has been suspended for more than 30 days, the Subcontractor's compensation shall be equitably adjusted for increases in cost resulting from the suspension, provided, however, that no such adjustment will be made to the compensation of an Subcontractor who is compensated as a proportion of the total project cost.

§ 5.4.3 Upon assignment to the Owner under this Section 5.4, the Owner may further assign the subcontract to a successor contractor or other entity.

ARTICLE 6 CONSTRUCTION BY OWNER OR BY SEPARATE CONTRACTORS

§ 6.1 Owner's Right to Perform Construction and to Award Separate Contracts

§ 6.1.1 The term "Separate Contractor(s)" shall mean other contractors retained by the Owner under separate agreements.. The Owner reserves the right to perform construction or operations related to the Project with the Owner's own forces, and to award separate contracts in connection with other portions of the Project or other construction or operations on the site. If the Contractor claims that delay or is involved because of such action by the Owner, the Contractor shall make such Claim as is permitted in Articles 8 and 15.

§ 6.1.2 When separate contracts are awarded for different portions of the Project or other construction or operations on the site, the term "Contractor" in the Contract Documents in each case shall mean the Contractor who executes each separate Owner-Contractor Agreement.

§ 6.1.3 The Owner shall provide for coordination of the activities of the Owner's own forces and of each Separate Contractor with the Work of the Contractor, who shall cooperate with them. The Contractor shall participate with any Separate Contractors and the Owner in reviewing their construction schedules. The Contractor shall make any revisions to its construction schedule deemed necessary after a joint review and mutual agreement. The construction schedules shall then constitute the schedules to be used by the Contractor, Separate Contractors, and the Owner until subsequently revised.

§ 6.1.4 INTENTIONALLY OMITTED

§ 6.2 Mutual Responsibility

§ 6.2.1 The Contractor shall afford the Owner and Separate Contractors reasonable opportunity for introduction and storage of their materials and equipment and performance of their activities, and shall connect and coordinate the Contractor's construction and operations with theirs as required by the Contract Documents.

§ 6.2.2 If part of the Contractor's Work depends for proper execution or results upon construction or operations by the Owner or a Separate Contractor, the Contractor shall, prior to proceeding with that portion of the Work, promptly notify the Architect of apparent discrepancies or defects in the construction or operations by the Owner or Separate Contractor that would render it unsuitable for proper execution and results of the Contractor's Work. Failure of the Contractor to notify the Architect of apparent discrepancies or defects prior to proceeding with the Work shall constitute an acknowledgment that the Owner's or Separate Contractor's completed or partially completed construction is fit and proper to receive the Contractor's Work. The Contractor shall not be responsible for discrepancies or defects in the construction or operations by the Owner or Separate Contractor that are not apparent.

§ 6.2.3 The Contractor shall reimburse the Owner for costs the Owner incurs that are payable to a Separate Contractor because of the Contractor's delays, improperly timed activities or defective construction. The Owner shall be responsible to the Contractor for costs the Contractor incurs because of a Separate Contractor's delays, improperly timed activities, damage to the Work or defective construction.

§ 6.2.4 The Contractor shall promptly remedy damage that the Contractor wrongfully causes to completed or partially completed construction or to property of the Owner or Separate Contractor as provided in Section 10.2.5. If such separate contractor sues or initiates an arbitration proceeding against the Owner on account of any damage alleged to have been caused by the Contractor, the Owner shall notify the Contractor, who shall defend such proceedings at the Contractor's expense, and if any judgment or award against the Owner arises therefrom, the Contractor shall pay or satisfy it and shall reimburse the Owner for all attorneys' fees and court or arbitration costs which the Owner has incurred.

§ 6.2.5 The Owner and each Separate Contractor shall have the same responsibilities for cutting and patching as are described for the Contractor in Section 3.14.

§ 6.3 Owner's Right to Clean Up

If a dispute arises among the Contractor, Separate Contractors, and the Owner as to the responsibility under their respective contracts for maintaining the premises and surrounding area free from waste materials and rubbish, the Owner may clean up and the Architect will allocate the cost among those responsible.

ARTICLE 7 CHANGES IN THE WORK

§ 7.1 General

§ 7.1.1 Changes in the Work may be accomplished after execution of the Contract, and without invalidating the Contract, by Change Order, Construction Change Directive or order for a minor change in the Work, subject to the limitations stated in this Article 7 and elsewhere in the Contract Documents.

§ 7.1.2 A Change Order shall be based upon agreement among the Owner, Contractor, and Architect. A Construction Change Directive requires agreement by the Owner and Architect and may or may not be agreed to by the Contractor. An order for a minor change in the Work may be issued by the Architect alone.

§ 7.1.3 Changes in the Work shall be performed under applicable provisions of the Contract Documents. The Contractor shall proceed promptly with changes in the Work, unless otherwise provided in the Change Order, Construction Change Directive, or order for a minor change in the Work.

§ 7.1.4 Except as permitted in Paragraph 7.3, a change in the Contract Sum or the Contract Time shall be accomplished only by a written Change Order executed before the Work is performed. Accordingly, no course of conduct or dealings between the parties, nor express or implied acceptance of alterations or additions to the Work, and no claim that Owner has been unjustly enriched by any alteration of or addition to the Work, whether or not there is, in fact, any unjust enrichment to the Work, shall be the basis of any claim to an increase in any amounts due under the Contract Documents or a change in any time period provided for in the Contract Documents.

§ 7.2 Change Orders

§ 7.2.1 A Change Order is a written instrument prepared by the Architect and signed by the Owner, Contractor, and Architect stating their agreement upon all of the following:

- .1 The change in the Work;
- .2 The amount of the adjustment, if any, in the Contract Sum; and
- .3 The extent of the adjustment, if any, in the Contract Time.

§ 7.2.2 Agreement on any Change Order shall constitute a final settlement of all matters relating to the change in the Work that is the subject of the Change Order, including, but not limited to, all direct and indirect costs associated with such change and any and all adjustments to the Contract Sum and the Contract Time.

§ 7.3 Construction Change Directives

§ 7.3.1 A Construction Change Directive is a written order prepared by the Architect and signed by the Owner and Architect, directing a change in the Work prior to agreement on adjustment, if any, in the Contract Sum or Contract Time, or both. The Owner may by Construction Change Directive, without invalidating the Contract, order changes in the Work within the general scope of the Contract consisting of additions, deletions, or other revisions, the Contract Sum and Contract Time being adjusted accordingly.

§ 7.3.2 A Construction Change Directive shall be used in the absence of total agreement on the terms of a Change Order.

§ 7.3.3 If the Construction Change Directive provides for an adjustment to the Contract Sum, the adjustment shall be based on one of the following methods:

- .1 Mutual acceptance of a lump sum properly itemized and supported by sufficient substantiating data to permit evaluation;
- .2 Unit prices stated in the Contract Documents or subsequently agreed upon;
- .3 Cost to be determined in a manner agreed upon by the parties and a mutually acceptable fixed or percentage fee; or
- .4 As provided in Section 7.3.4.

§ 7.3.4 If the Contractor does not respond promptly or disagrees with the method for adjustment in the Contract Sum, the Architect shall determine the adjustment on the basis of reasonable expenditures and savings of those performing the Work attributable to the change, including, in case of an increase in the Contract Sum, an amount for overhead and profit as set forth in the Agreement, or if no such amount is set forth in the Agreement, a reasonable amount. In such case, and also under Section 7.3.3.3, the Contractor shall keep and present, in such form as the Architect may prescribe, an itemized accounting together with appropriate supporting data. Unless otherwise provided in the Contract Documents, costs for the purposes of this Section 7.3.4 shall be limited to the following:

- .1 Costs of labor, including applicable payroll taxes, fringe benefits required by agreement or custom, workers' compensation insurance, and other employee costs approved by the Architect;
- .2 Costs of materials, supplies, and equipment, including cost of transportation, whether incorporated or consumed;
- .3 Rental costs of machinery and equipment, exclusive of hand tools, whether rented from the Contractor or others;
- .4 Costs of premiums for all bonds and insurance, permit fees, and sales, use, or similar taxes, directly related to the change; and
- .5 Costs of supervision and field office personnel directly attributable to the change.

§ 7.3.5 If the Contractor disagrees with the adjustment in the Contract Time, the Contractor may make a Claim in accordance with applicable provisions of Article 15.

§ 7.3.6 Upon receipt of a Construction Change Directive, the Contractor shall promptly proceed with the change in the Work involved and advise the Architect, in writing, of the Contractor's agreement or disagreement with the method, if any, provided in the Construction Change Directive for determining the proposed adjustment in the Contract Sum or Contract Time.

§ 7.3.7 A Construction Change Directive signed by the Contractor indicates the Contractor's agreement therewith, including adjustment in Contract Sum and Contract Time or the method for determining them. Such agreement shall be effective immediately and shall be recorded as a Change Order.

§ 7.3.8 The amount of credit to be allowed by the Contractor to the Owner for a deletion or change that results in a net decrease in the Contract Sum shall be actual net cost as confirmed by the Architect. When both additions and credits covering related Work or substitutions are involved in a change, the allowance for overhead and profit shall be figured on the basis of net increase, if any, with respect to that change.

§ 7.3.9 Pending final determination of the total cost of a Construction Change Directive to the Owner, the Contractor may request payment for Work completed under the Construction Change Directive in Applications for Payment. The Architect will make an interim determination for purposes of monthly certification for payment for those costs and certify for payment the amount that the Architect determines, in the Architect's professional judgment, to be necessary for the Contractor to proceed with the Work. The Architect's interim determination of cost shall adjust the Contract Sum on the same basis as a Change Order, subject to the right of either party to disagree and assert a Claim in accordance with Article 15.

§ 7.3.10 When the Owner and Contractor agree with a determination made by the Architect concerning the adjustments in the Contract Sum and Contract Time, or otherwise reach agreement upon the adjustments, such agreement shall be effective immediately and the Architect will prepare a Change Order. Change Orders may be issued for all or any part of a Construction Change Directive.

§ 7.4 Minor Changes in the Work

The Architect may order minor changes in the Work that are consistent with the intent of the Contract Documents and do not involve an adjustment in the Contract Sum or an extension of the Contract Time. The Architect's order for minor changes shall be in writing. If the Contractor believes that the proposed minor change in the Work will affect the Contract Sum or Contract Time, the Contractor shall notify the Architect and shall not proceed to implement the change in the Work. If the Contractor performs the Work set forth in the Architect's order for a minor change without prior notice to the Architect that such change will affect the Contract Sum or Contract Time, the Contractor waives any adjustment to the Contract Sum or extension of the Contract Time.

ARTICLE 8 TIME

§ 8.1 Definitions

§ 8.1.1 Unless otherwise provided, Contract Time is the period of time, including authorized adjustments, allotted in the Contract Documents for Substantial Completion of the Work.

§ 8.1.2 The date of commencement of the Work is the date established in the Agreement. Time is of the essence of all Milestone Dates in the accepted Construction Schedule, as such Schedule may be revised and accepted by the Owner.

§ 8.1.3 The date of Substantial Completion is the date certified by the Architect in accordance with Section 9.8.

§ 8.1.4 The term "day" as used in the Contract Documents shall mean calendar day unless otherwise specifically defined.

§ 8.2 Progress and Completion

§ 8.2.1 Time limits stated in the Contract Documents are of the essence of the Contract. By executing the Agreement, the Contractor confirms that the Contract Time is a reasonable period for performing the Work.

§ 8.2.2 The Contractor shall not commence the Work prior to receiving written notice to commence from the Owner or prior to the effective date of insurance required to be furnished by the Contractor and Owner.

§ 8.2.3 The Contractor shall proceed expeditiously with adequate forces and shall achieve Substantial Completion within the Contract Time.

§ 8.3 Delays and Extensions of Time

§ 8.3.1 If the Contractor is delayed at any time in the commencement or progress of the Work by (1) an act or neglect of the Owner or Architect, of an employee of either, or of a Separate Contractor; (2) by changes ordered in the Work; (3) by labor disputes, fire, unusual delay in deliveries, unavoidable casualties, adverse weather conditions documented in accordance with Section 15.1.6.2, or other causes beyond the Contractor's control; (4) by delay authorized by the Owner pending mediation and binding dispute resolution; or (5) by other causes that the Contractor asserts, and the Architect determines, justify delay, then the Contract Time shall be extended for such reasonable time as the Architect may determine. Nothing in this Section 8.3.1 shall absolve the Architect of liability for delays due to the negligence of the Architect or its employees or consultants, or failure to comply with the agreement between the Owner and the Architect or the Contract Documents by the Architect or by the Architect's employees or consultants.

§ 8.3.2 Claims relating to time shall be made in accordance with applicable provisions of Article 15.

§ 8.3.3 Notwithstanding anything to the contrary in the Contract Documents, an extension of the Contract Time, to the extent permitted under Subparagraph 8.3.1, shall be the sole and exclusive remedy of the Contractor for any delay, hindrance, disruption, interference or obstruction to the Work (collectively referred to in this Subparagraph 8.3.3 as "Delays"). Except as provided in Section 6.2.6 of the Contract, in no event shall the Contractor be entitled to any compensation or recovery of any damages in connection with any Delay, including, without limitation, consequential damages, loss of efficiency or productivity costs, acceleration costs, lost opportunity costs, impact damages, extended overhead costs, or other similar remuneration.

§ 8.3.4 Time is of the essence in the completion of the Work by the Contractor.

ARTICLE 9 PAYMENTS AND COMPLETION

§ 9.1 Contract Sum

§ 9.1.1 The Contract Sum is stated in the Agreement and, including authorized adjustments, is the total amount payable by the Owner to the Contractor for performance of the Work under the Contract Documents.

§ 9.1.2 If unit prices are stated in the Contract Documents or subsequently agreed upon, and if quantities originally contemplated are materially changed so that application of such unit prices to the actual quantities causes substantial inequity to the Owner or Contractor, the applicable unit prices shall be equitably adjusted.

§ 9.2 Schedule of Values

Where the Contract is based on a stipulated sum or Guaranteed Maximum Price, the Contractor shall submit a schedule of values to the Architect within thirty (30) days of the first of the Contract Award or Preconstruction Meeting, allocating the entire Contract Sum to the various portions of the Work. The schedule of values shall be prepared in the form, and supported by the data to substantiate its accuracy, required by the Architect. This schedule, unless objected to by the Architect, shall be used as a basis for reviewing the Contractor's Applications for Payment. Any changes to the schedule of values shall be submitted to the Architect and supported by such data to substantiate its accuracy as the Architect may require, and unless objected to by the Architect, shall be used as a basis for reviewing the Contractor's subsequent Applications for Payment.

§ 9.3 Applications for Payment

§ 9.3.1 At least ten days before the date established for each progress payment, the Contractor shall submit to the Architect an itemized Application for Payment prepared in accordance with the schedule of values, if required under Section 9.2, for completed portions of the Work. The application shall be notarized and supported by all data substantiating the Contractor's right to payment that the Owner or Architect require, such as copies of requisitions, and releases and waivers of liens from Subcontractors and suppliers, and shall reflect retainage if provided for in the Contract Documents.

§ 9.3.1.1 As provided in Section 7.3.9, such applications may include requests for payment on account of changes in the Work that have been properly authorized by Construction Change Directives, or by interim determinations of the Architect, but not yet included in Change Orders.

§ 9.3.1.2 Applications for Payment shall not include requests for payment for portions of the Work for which the Contractor does not intend to pay a Subcontractor or supplier, unless such Work has been performed by others whom the Contractor intends to pay.

§ 9.3.1.3 Each application for payment shall be accompanied by the following, all in form and substance satisfactory to the Owner: (i) a duly executed Contractor's partial lien waiver; (ii) duly executed partial lien waivers from all Subcontractors and, when reasonably required, from material suppliers and lower tier Subcontractors establishing payment or satisfaction of payment of all amounts requested by the Contractor on behalf of such entities or persons in any previous Application for Payment; and (iii) all information and materials required to comply with the requirements of the Contract Documents or reasonably requested by the Owner or the Architect.

§ 9.3.2 Unless otherwise provided in the Contract Documents, payments shall be made on account of materials and equipment delivered and suitably stored at the site for subsequent incorporation in the Work. If approved in advance by the Owner, payment may similarly be made for materials and equipment suitably stored off the site at a location agreed upon in writing. Payment for materials and equipment stored on or off the site shall be conditioned upon compliance by the Contractor with procedures satisfactory to the Owner to establish the Owner's title to such materials and equipment or otherwise protect the Owner's interest, and shall include the costs of applicable insurance, storage, and transportation to the site, for such materials and equipment stored off the site.

§ 9.3.3 The Contractor warrants that title to all Work covered by an Application for Payment will pass to the Owner no later than the time of payment. The Contractor further warrants that upon submittal of an Application for Payment all Work for which Certificates for Payment have been previously issued and payments received from the Owner shall be free and clear of liens, claims, security interests, or encumbrances, in favor of the Contractor, Subcontractors, suppliers, or other persons or entities that provided labor, materials, and equipment relating to the Work.

§ 9.4 Certificates for Payment

§ 9.4.1 The Architect will, within seven days after receipt of the Contractor's Application for Payment, either (1) issue to the Owner a Certificate for Payment in the full amount of the Application for Payment, with a copy to the Contractor; or (2) issue to the Owner a Certificate for Payment for such amount as the Architect determines is properly due, and notify the Contractor and Owner of the Architect's reasons for withholding certification in part as provided in Section 9.5.1; or (3) withhold certification of the entire Application for Payment, and notify the Contractor and Owner of the Architect's reason for withholding certification in whole as provided in Section 9.5.1.

§ 9.4.2 The issuance of a Certificate for Payment will constitute a representation by the Architect solely to the Owner, based on the Architect's evaluation of the Work as provided in the Contract Documents and/or the data in the Application for Payment, that, to the best of the Architect's knowledge, information, and belief, the Work has progressed to the point indicated, the quality of the Work is in accordance with the Contract Documents, and that the Contractor is entitled to payment in the amount certified. The foregoing representations are subject to an evaluation of the Work for conformance with the Contract Documents upon Substantial Completion, to results of subsequent tests and inspections, to correction of minor deviations from the Contract Documents prior to completion, and to specific qualifications expressed by the Architect. However, the issuance of a Certificate for Payment will not be a representation that the Architect has (1) made exhaustive or continuous on-site inspections to check the quality or quantity of the Work; (2) reviewed construction means, methods, techniques, sequences, or procedures; or (3) made examination to ascertain how or for what purpose the Contractor has used money previously paid on account of the Contract Sum. Notwithstanding anything herein to the contrary, issuance of a Certificate for Payment by the Architect is a recommendation only; payment to the Contractor of amounts certified in a Certificate for Payment is subject to the Owner's approval.

§ 9.5 Decisions to Withhold Certification

§ 9.5.1 The Architect may withhold a Certificate for Payment in whole or in part, to the extent reasonably necessary to protect the Owner, if in the Architect's opinion the representations to the Owner required by Section 9.4.2 cannot be made. If the Architect is unable to certify payment in the amount of the Application, the Architect will notify the Contractor and Owner as provided in Section 9.4.1. If the Contractor and Architect cannot agree on a revised amount, the Architect will promptly issue a Certificate for Payment for the amount for which the Architect is able to

make such representations to the Owner. The Architect may also withhold a Certificate for Payment or, because of subsequently discovered evidence, may nullify the whole or a part of a Certificate for Payment previously issued, to such extent as may be necessary in the Architect's opinion to protect the Owner from loss for which the Contractor is responsible, including loss resulting from acts and omissions described in Section 3.3.2, because of

- .1 defective Work not remedied;
- .2 third party claims filed or reasonable evidence indicating probable filing of such claims, unless security acceptable to the Owner is provided by the Contractor;
- .3 failure of the Contractor to make payments properly to Subcontractors or suppliers for labor, materials or equipment;
- .4 reasonable evidence that the Work cannot be completed for the unpaid balance of the Contract Sum;
- .5 damage to the Owner or a Separate Contractor;
- .6 reasonable evidence that the Work will not be completed within the Contract Time, and that the unpaid balance would not be adequate to cover actual or liquidated damages for the anticipated delay; or
- .7 repeated failure to carry out the Work in accordance with the Contract Documents.

§ 9.5.2 When either party disputes the Architect's decision regarding a Certificate for Payment under Section 9.5.1, in whole or in part, that party may submit a Claim in accordance with Article 15. The Owner shall not be deemed to be in default by reason of withholding payment while any of the above grounds remain uncured, nor shall any interest accrue or be payable with respect to any payments so withheld.

§ 9.5.3 When the reasons for withholding certification are removed, certification will be made for amounts previously withheld.

§ 9.5.4 If the Architect withholds certification for payment under Section 9.5.1.3, the Owner may, at its sole option, issue joint checks to the Contractor and to any Subcontractor or supplier to whom the Contractor failed to make payment for Work properly performed or material or equipment suitably delivered. If the Owner makes payments by joint check, the Owner shall notify the Architect and the Contractor shall reflect such payment on its next Application for Payment.

§ 9.6 Progress Payments

§ 9.6.1 After the Architect has issued a Certificate for Payment, the Owner shall make payment in the manner and within the time provided in the Contract Documents, and shall so notify the Architect.

§ 9.6.2 The Contractor shall pay each Subcontractor, no later than five (5) days after receipt of payment from the Owner, the amount to which the Subcontractor is entitled, reflecting percentages actually retained from payments to the Contractor on account of the Subcontractor's portion of the Work. The Contractor shall, by appropriate agreement with each Subcontractor, require each Subcontractor to make payments to Sub-subcontractors in a similar manner. Notwithstanding anything in this Subparagraph 9.6.2 to the contrary, the Owner may elect, in the Owner's reasonable discretion, to make any payment requested by the Contractor on behalf of a Subcontractor or material supplier of any tier jointly payable to the Contractor and such Subcontractor or material supplier, or directly payable to such Subcontractor or material supplier. The Contractor and such Subcontractor or material supplier shall be responsible for the allocation and disbursement of funds included as part of any such joint payment. In no event shall any joint payment be construed to create any (i) contract between the Owner and a subcontractor or material supplier of any tier, (ii) obligations from the Owner to such subcontractor or material supplier, or (iii) rights in such subcontractor or material supplier against the Owner. All such payments by the Owner shall be a pro tanto discharge of sums due the Contractor.

§ 9.6.3 The Architect will, on request, furnish to a Subcontractor, if practicable, information regarding percentages of completion or amounts applied for by the Contractor and action taken thereon by the Architect and Owner on account of portions of the Work done by such Subcontractor.

§ 9.6.4 The Owner has the right to request written evidence from the Contractor that the Contractor has properly paid Subcontractors and suppliers amounts paid by the Owner to the Contractor for subcontracted Work. The Owner may contact Subcontractors and suppliers to ascertain whether they have been properly paid. Neither the Owner nor

Architect shall have an obligation to pay, or to see to the payment of money to, a Subcontractor or supplier, except as may otherwise be required by law.

§ 9.6.5 The Contractor's payments to suppliers shall be treated in a manner similar to that provided in Sections 9.6.2, 9.6.3 and 9.6.4.

§ 9.6.6 A Certificate for Payment, a progress payment, filing of a final grant application with the Department or partial or entire use or occupancy of the Project by the Owner shall not constitute acceptance of Work not in accordance with the Contract Documents.

§ 9.6.7 Unless the Contractor provides the Owner with a payment bond in the full penal sum of the Contract Sum, payments received by the Contractor for Work properly performed by Subcontractors or provided by suppliers shall be held by the Contractor for those Subcontractors or suppliers who performed Work or furnished materials, or both, under contract with the Contractor for which payment was made by the Owner. Nothing contained herein shall require money to be placed in a separate account and not commingled with money of the Contractor, create any fiduciary liability or tort liability on the part of the Contractor for breach of trust, or entitle any person or entity to an award of punitive damages against the Contractor for breach of the requirements of this provision.

§ 9.6.8 Provided the Owner has fulfilled its payment obligations under the Contract Documents, the Contractor shall defend and indemnify the Owner from all loss, liability, damage or expense, including reasonable attorney's fees and litigation expenses, arising out of any lien claim or other claim for payment by any Subcontractor or supplier of any tier. Upon receipt of notice of a lien claim or other claim for payment, the Owner shall notify the Contractor. If approved by the applicable court, when required, the Contractor may substitute a surety bond for the property against which the lien or other claim for payment has been asserted.

§ 9.7 Failure of Payment

If the Architect does not issue a Certificate for Payment or provide the Contractor with a written explanation for the reason for withholding such Certificate for Payment, through no fault of the Contractor, within seven days after receipt of the properly submitted Application for Payment, or if the Owner does not pay the Contractor or provide the Contractor with a written explanation of the reason for withholding payment within seven days after the date established in the Contract Documents, the amount certified by the Architect or if the Owner does not so pay an amount awarded by binding dispute resolution, then the Contractor may, upon seven additional days' notice to the Owner and Architect, stop the Work until payment of the amount owing or an explanation of the reason for withholding such payments has been received. The Contract Time shall be extended appropriately and the Contract Sum shall be increased by the amount of the Contractor's reasonable costs of shutdown, delay and start-up, plus interest as provided for in the Contract Documents.

§ 9.8 Substantial Completion

§ 9.8.1 Substantial Completion is the stage in the progress of the Work when the Work or designated portion thereof is sufficiently complete in accordance with the Contract Documents so that the Owner can occupy or utilize the Work for its intended use. As a condition precedent to Substantial Completion, the Contractor shall assemble and deliver to the Owner (1) all maintenance and operating manuals; (2) marked sets of field record drawings and specifications reflecting as-built conditions; (3) drawings reflecting the location of any concealed utilities, mechanical or electrical systems and components; (4) any special guaranties or warranties required by the Contract Documents; (5) all guaranties and warranties from Subcontractors, vendors, suppliers or manufacturers; (6) a list of the names, addresses and telephone numbers of all subcontractors and any other persons providing guaranties or warranties; (7) a permanent Certificate of Occupancy; (8) Operating permits for any mechanical equipment; and (9) any other permits, approvals, licenses, and other documents from any governmental authority having jurisdiction thereof necessary for the beneficial use and occupancy of the Project.

§ 9.8.2 When the Contractor considers that the Work, or a portion thereof which the Owner agrees to accept separately, is substantially complete, the Contractor shall prepare and submit to the Architect a comprehensive list of items to be completed or corrected prior to final payment. Failure to include an item on such list does not alter the responsibility of the Contractor to complete all Work in accordance with the Contract Documents.

§ 9.8.3 Upon receipt of the Contractor's list, the Architect will make an inspection to determine whether the Work or designated portion thereof is substantially complete. If the Architect's inspection discloses any item, whether or not

included on the Contractor's list, which is not sufficiently complete in accordance with the Contract Documents so that the Owner can occupy or utilize the Work or designated portion thereof for its intended use, the Contractor shall, before issuance of the Certificate of Substantial Completion, complete or correct such item upon notification by the Architect. In such case, the Contractor shall then submit a request for another inspection by the Architect to determine Substantial Completion.

§ 9.8.4 When the Work or designated portion thereof is substantially complete, the Architect will prepare a Certificate of Substantial Completion that shall establish the date of Substantial Completion; establish responsibilities of the Owner and Contractor for security, maintenance, heat, utilities, damage to the Work and insurance; and fix the time within which the Contractor shall finish all items on the list accompanying the Certificate. Warranties required by the Contract Documents shall commence on the date of Substantial Completion of the Work or designated portion thereof unless otherwise provided in the Certificate of Substantial Completion.

§ 9.8.5 The Certificate of Substantial Completion shall be submitted to the Owner and Contractor for their written acceptance of responsibilities assigned to them in the Certificate. Upon such acceptance, and consent of surety if any, the Owner shall make payment of retainage applying to the Work or designated portion thereof. Such payment shall be adjusted for Work that is incomplete or not in accordance with the requirements of the Contract Documents. Owner shall be entitled to retain two hundred percent (200%) of the estimated cost to reach Final Completion.

§ 9.9 Partial Occupancy or Use

§ 9.9.1 The Owner may occupy or use any completed or partially completed portion of the Work at any stage when such portion is designated by separate agreement with the Contractor, provided such occupancy or use is consented to by the insurer and authorized by public authorities having jurisdiction over the Project. Such partial occupancy or use may commence whether or not the portion is substantially complete, provided the Owner and Contractor have accepted in writing the responsibilities assigned to each of them for payments, retainage, if any, security, maintenance, heat, utilities, damage to the Work and insurance, and have agreed in writing concerning the period for correction of the Work and commencement of warranties required by the Contract Documents. When the Contractor considers a portion substantially complete, the Contractor shall prepare and submit a list to the Architect as provided under Section 9.8.2. Consent of the Contractor to partial occupancy or use shall not be unreasonably withheld. The stage of the progress of the Work shall be determined by written agreement between the Owner and Contractor or, if no agreement is reached, by decision of the Architect.

§ 9.9.2 Immediately prior to such partial occupancy or use, the Owner, Contractor, and Architect shall jointly inspect the area to be occupied or portion of the Work to be used in order to determine and record the condition of the Work.

§ 9.9.3 Unless otherwise agreed upon, partial occupancy or use of a portion or portions of the Work shall not constitute acceptance of Work not complying with the requirements of the Contract Documents.

§ 9.10 Final Completion and Final Payment

§ 9.10.1 Upon receipt of the Contractor's notice that the Work is ready for final inspection and acceptance and upon receipt of a final Application for Payment, the Architect will promptly make such inspection. When the Architect finds the Work acceptable under the Contract Documents and the Contract fully performed, the Architect will promptly issue a final Certificate for Payment stating that to the best of the Architect's knowledge, information and belief, and on the basis of the Architect's on-site visits and inspections, the Work has been completed in accordance with the Contract Documents and that the entire balance found to be due the Contractor and noted in the final Certificate is due and payable. The Architect's final Certificate for Payment will constitute a further representation that conditions listed in Section 9.10.2 as precedent to the Contractor's being entitled to final payment have been fulfilled.

§ 9.10.2 Neither final payment nor any remaining retained percentage shall become due until the Contractor submits to the Architect (1) an affidavit that payrolls, bills for materials and equipment, and other indebtedness connected with the Work for which the Owner or the Owner's property might be responsible or encumbered (less amounts withheld by Owner) have been paid or otherwise satisfied, (2) a certificate evidencing that insurance required by the Contract Documents to remain in force after final payment is currently in effect and will not be canceled or allowed to expire until at least 30 days' prior written notice has been given to the Owner, (3) a written statement that the

Contractor knows of no substantial reason that the insurance will not be renewable to cover the period required by the Contract Documents, (4) consent of surety, if any, to final payment and (5), statements in a form satisfactory to the Owner that in consideration of all prior payments and of final payment, the Contractor and its Subcontractors release and forever discharge the Owner from all mechanic's liens, claims, demands, obligations and liabilities of every kind arising out of or relating to the Contract or the Project other than those Claims specifically enumerated in the statement. If a Subcontractor refuses to furnish a release or waiver required by the Owner, the Contractor may furnish a bond satisfactory to the Owner to indemnify the Owner against such lien. If such lien remains unsatisfied after payments are made, the Contractor shall refund to the Owner all money that the Owner may be compelled to pay in discharging such lien, including all costs and attorneys' fees.

§ 9.10.3 If, after Substantial Completion of the Work, final completion thereof is materially delayed through no fault of the Contractor or by issuance of Change Orders affecting final completion, and the Architect so confirms, the Owner shall, upon application by the Contractor and certification by the Architect, and without terminating the Contract, make payment of the balance due for that portion of the Work fully completed, corrected, and accepted. If the remaining balance for Work not fully completed or corrected is less than retainage stipulated in the Contract Documents, and if bonds have been furnished, the written consent of the surety to payment of the balance due for that portion of the Work fully completed and accepted shall be submitted by the Contractor to the Architect prior to certification of such payment. Such payment shall be made under terms and conditions governing final payment, except that it shall not constitute a waiver of Claims.

§ 9.10.4 INTENTIONALLY OMITTED

§ 9.10.5 Acceptance of final payment by the Contractor, a Subcontractor, or a supplier, shall constitute a waiver of claims by that payee except those previously made in writing and identified by that payee as unsettled at the time of final Application for Payment.

ARTICLE 10 PROTECTION OF PERSONS AND PROPERTY

§ 10.1 Safety Precautions and Programs

The Contractor shall be responsible for initiating, maintaining, and supervising all safety precautions and programs in connection with the performance of the Contract.

§ 10.2 Safety of Persons and Property

§ 10.2.1 The Contractor shall take reasonable precautions for safety of, and shall provide reasonable protection to prevent damage, injury, or loss to

- .1 employees on the Work and other persons who may be affected thereby;
- .2 the Work and materials and equipment to be incorporated therein, whether in storage on or off the site, under care, custody, or control of the Contractor, a Subcontractor, or a Sub-subcontractor; and
- .3 other property at the site or adjacent thereto, such as trees, shrubs, lawns, walks, pavements, roadways, structures, and utilities not designated for removal, relocation, or replacement in the course of construction.

§ 10.2.2 The Contractor shall comply with, and give notices required by the Conditions and applicable laws, statutes, ordinances, codes, rules and regulations, and lawful orders of public authorities, bearing on safety of persons or property or their protection from damage, injury, or loss.

§ 10.2.3 The Contractor shall implement, erect, and maintain, as required by existing conditions and performance of the Contract, reasonable safeguards for safety and protection, including posting danger signs and other warnings against hazards; promulgating safety regulations; and notifying the owners and users of adjacent sites and utilities of the safeguards. The Contractor shall also be responsible, at the Contractor's sole cost and expense, for all measures necessary to protect any property adjacent to the Project and improvements thereon. Any damage to such property or improvements shall be promptly repaired by the Contractor at its sole cost and expense.

§ 10.2.4.1 When there are indications that the use of explosives or other hazardous material, equipment or unusual methods is necessary for execution of the Work, the Contractor shall give the Owner and Architect reasonable advance notice of the conditions.

§ 10.2.4.2 The Contractor shall be solely responsible for the handling, storage and use of explosive or other hazardous materials when their use is permitted.

§ 10.2.4.3 The Contractor shall not bring explosives onto the site or use such in the Work without the prior written permission of the Architect and the Owner. For such use, the Contractor shall obtain necessary permits with copies to the Architect and the Owner. The Contractor shall furnish the Owner and Architect with certificates indicating proper and adequate insurance.

§ 10.2.4 When use or storage of explosives or other hazardous materials or equipment, or unusual methods are necessary for execution of the Work, the Contractor shall exercise utmost care and carry on such activities under supervision of properly qualified personnel.

§ 10.2.5 The Contractor shall promptly remedy damage and loss to property referred to in subparagraphs 10.2.1.2, 10.2.1.3 and 10.2.1.4. If the damage or loss is due in whole or in part to the Contractor's failure to take the precautions required by this paragraph 10.2, the Contractor shall bear the cost. The foregoing obligations of the Contractor are in addition to the Contractor's obligations under Section 3.18.

§ 10.2.6 The Contractor shall designate a responsible member of the Contractor's organization at the site whose duty shall be the prevention of accidents. This person shall be the Contractor's superintendent unless otherwise designated by the Contractor in writing to the Owner and Architect.

§ 10.2.7 The Contractor shall not permit any part of the construction or site to be loaded so as to cause damage or create an unsafe condition.

§ 10.2.8 The Contractor shall at all times provide protection against weather (snow, rain, wind, storms or heat) so as to maintain all Work, materials, apparatus and fixtures free from damage. At the end of the day's work, all new Work likely to be damaged shall be reasonably protected against such weather.

§ 10.2.9 The Contractor shall provide adequate fire protection for all operations associated with the Work, and such protection must meet all applicable federal (including OSHA), State and municipal regulations.

§ 10.2.10 The Contractor shall remove and replace with new work at the Contractor's own expense, any Work damaged by failure to provide protection pursuant to Sections 10.2.8, 10.2.9 or § 10.2.11.

§ 10.2.11 The Contractor shall be responsible, to the extent not covered by insurance, for damage, loss or liability due to theft or vandalism to the Work and stored materials when work is not in progress at night, on weekends or holidays.

§ 10.2.12 If either party suffers injury or damage to person or property because of an act or omission of the other party, or of others for whose acts such party is legally responsible, notice of the injury or damage, whether or not insured, shall be given to the other party within a reasonable time not exceeding 21 days after discovery. The notice shall provide sufficient detail to enable the other party to investigate the matter.

§ 10.2.13 The Contractor shall promptly report in writing to the Owner and Architect all accidents arising out of or in connection with the Work that cause death, personal injury, or property damage, giving full details and statements of any witnesses. In addition, if death, serious personal injuries, or serious damages are caused, the accident shall be reported immediately by telephone or messenger to the Owner and the Architect.

§ 10.2.14 The Contractor shall provide and maintain in good operating condition suitable and adequate fire protection equipment and services, and shall comply with all reasonable recommendations regarding fire protection made by the representatives of the fire insurance company carrying insurance on the Work or by the local fire chief or fire marshal. The area within the site limits shall be kept orderly and clean, and all combustible rubbish shall be promptly removed from the site.

§ 10.2.15 When all or a portion of the Work is suspended for any reason, the Contractor shall securely fasten down all coverings and protect the Work, as necessary, from injury by any cause.

§ 10.2.16 The Contractor shall at all times protect excavations, trenches, buildings and materials, from rain water, ground water, backup or leakage of sewers, drains and other piping, and shall remove promptly any accumulation of

water. The Contractor shall provide and operate all pumps, piping and other equipment necessary to this end.

§ 10.2.17 The Contractor shall remove snow and ice which might result in damage or delay to the Work.

§ 10.2.18 During the progress of the Work and at all times prior to the date of Substantial Completion or occupancy of the Work by the Owner, whichever is earlier, the Contractor shall provide temporary heat, ventilation, and enclosure, adequate to permit the Work to proceed in a timely fashion, and to prevent damage to completed Work or Work in progress, or to materials stored on the premises. The permanent heating and ventilation systems may be used for these purposes when available and appropriate, but the fuel cost shall be paid by the Owner.

§ 10.3 Hazardous Materials and Substances

§ 10.3.1 The Contractor is responsible for compliance with any requirements included in the Contract Documents regarding hazardous materials or substances. If the Contractor encounters a hazardous material or substance not addressed in the Contract Documents the Contractor shall immediately report the condition to the Owner and the Architect in writing and take reasonable precautions to prevent foreseeable bodily injury or death to persons resulting from a material or substance, including but not limited to asbestos or polychlorinated biphenyl (PCB). If such reasonable precautions will be inadequate to prevent foreseeable bodily injury and death, the Contractor shall immediately stop Work in the affected area and notify the Owner and Architect of the condition.

§ 10.3.2 Upon receipt of the Contractor's notice, the Owner shall obtain the services of a licensed laboratory to verify the presence or absence of the material or substance reported by the Contractor and, in the event such material or substance is found to be present, to cause it to be rendered harmless. When the material or substance has been rendered harmless, any Work that has been stopped in the affected area shall resume. By Change Order, the Contract Time shall be extended appropriately. Termination of the Contract by the Owner due to the discovery of Hazardous Materials on the Project site shall be Termination for Cause. The term "rendered harmless" shall be interpreted to mean that levels of hazardous materials including, but not limited to asbestos and polychlorinated biphenyl, are less than any applicable exposure standards set forth in OSHA regulations. In no event, however, shall the Owner have any responsibility for any substance or material that is brought to the Project site by the Contractor, any Subcontractor or any materialman or supplier or any entity for whom any of them is responsible. The Contractor agrees not to use any fill or other materials to be incorporated into the Work which are hazardous, toxic or comprised of any items that are hazardous or toxic except to the extent provided in Section 10.3.7.

§ 10.3.3 The Contractor shall not be liable for pre-existing, environmental matters on, under or about the premises which constitute the Project, including without limitation, those relating to fines, orders, injunctions, penalties, damages, contribution, cost recovery compensation, losses or injuries resulting from the release or threatened release of hazardous materials, special wastes or other contaminants into the environment, the development or growth of mold within or on any structures, air quality levels, and to the generation, use, storage, transportation or illegal disposal of solid wastes, hazardous materials, special wastes or other contaminants. This disclaimer of liability shall apply to all such claims against the Contractor, whether direct or indirect, including without limitation, third party claims for which the Owner is seeking indemnification from the Contractor, excluding, however, any such claims that are caused by the negligence of the Contractor or subcontractor for which the Contractor is responsible.

§ 10.3.4 The Owner shall not be responsible under this Section 10.3 for hazardous materials or substances the Contractor brings to the site unless such materials or substances are required by the Contract Documents. The Owner shall be responsible for hazardous materials or substances required by the Contract Documents, except to the extent of the Contractor's fault or negligence in the use and handling of such materials or substances.

§ 10.3.5 The Contractor shall reimburse the Owner for the cost and expense the Owner incurs (1) for remediation of hazardous materials or substances the Contractor brings to the site and negligently handles, or (2) where the

Contractor fails to perform its obligations under Section 10.3.1, except to the extent that the cost and expense are due to the Owner's fault or negligence.

§ 10.3.6 If, without negligence or intentional acts on the part of the Contractor, the Contractor is held liable by a government agency for the cost of remediation of a hazardous material or substance solely by reason of properly performing Work as required by the Contract Documents, the Owner shall reimburse the Contractor for all cost and expense thereby incurred.

§ 10.3.7 The Contractor will be solely responsible for compliance with laws and regulations governing the handling, storage, use or disposal of hazardous materials or wastes used, stored, generated, or disposed of in connection with construction of the Work, and shall obtain all permits and approvals, give all required notices, and observe all applicable procedures prescribed by the U.S. Environmental Protection Agency, the State of Connecticut and other governmental authorities having jurisdiction with respect to such activities. At Owner's request, Contractor shall furnish the Owner promptly with evidence satisfactory to Owner demonstrating the Contractor's compliance with such procedures, the giving of such notices, and the issuance of such permits and approvals, and shall indemnify Owner and hold Owner harmless with respect to any loss, damage or liability resulting from Contractor's failure to observe such procedures, give such notices, or obtain such permits and approvals. Contractor will be responsible for removal and disposal only of such "hazardous material" as is required to be removed by the Contract Documents or any such materials placed on the site by the Contractor or any party for which the Contractor is responsible.

§ 10.3.8 All material and equipment furnished under the Contract shall be free of asbestos and polychlorinated biphenyl (PCB). Any material or equipment containing these hazardous materials shall be considered defective and shall be removed by the Contractor at the Contractor's sole expense.

§ 10.4 Emergencies

In an emergency affecting safety of persons or property, the Contractor shall act, at the Contractor's discretion, to prevent threatened damage, injury, or loss. Additional compensation or extension of time claimed by the Contractor on account of an emergency shall be determined as provided in Article 15 and Article 7. The Contractor shall promptly notify insurers as applicable, the Architect and the Owner of the nature of the emergency. Immediately thereafter, the Contractor shall submit to the Architect and the Owner a written report including a description of circumstances of the emergency and details of action taken.

ARTICLE 11 INSURANCE AND BONDS

§ 11.1 Contractor's Insurance and Bonds

§ 11.1.1 The Contractor shall purchase and maintain insurance of the types and limits of liability, containing the endorsements, and subject to the terms and conditions, as described in the Agreement or elsewhere in the Contract Documents. The Contractor shall purchase and maintain the required insurance from an insurance company or insurance companies that are acceptable to the Owner and that are lawfully authorized to issue insurance in Connecticut. The Owner, Architect, and Architect's consultants shall be named as additional insureds under the Contractor's commercial general liability policy or as otherwise described in the Contract Documents.

The insurance required shall be maintained without interruption from the date of commencement of the Work until the date of final payment and termination of any coverage required to be maintained after final payment, and with respect to Contractor's completed operations coverages, as specified in the Contract Documents.

§ 11.1.2 The Contractor shall provide surety bonds of the types, for such penal sums, and subject to such terms and conditions as required by the Contract Documents. The Contractor shall purchase and maintain the required bonds from a company or companies that are acceptable to the Owner and that are lawfully authorized to issue surety bonds in Connecticut.

§ 11.1.3 Upon the request of any person or entity appearing to be a potential beneficiary of bonds covering payment of obligations arising under the Contract, the Contractor shall promptly furnish a copy of the bonds or shall authorize a copy to be furnished.

§ 11.1.4 Notice of Cancellation or Expiration of Contractor's Required Insurance. Within three (3) business days of the date the Contractor becomes aware of an impending or actual cancellation or expiration of any insurance required by the Contract Documents, the Contractor shall provide notice to the Owner of such impending or actual cancellation or expiration. Upon receipt of notice from the Contractor, the Owner shall, unless the lapse in coverage arises from an act or omission of the Owner, have the right to stop the Work until the lapse in coverage has been cured by the procurement of replacement coverage by the Contractor. The furnishing of notice by the Contractor shall not relieve the Contractor of any contractual obligation to provide any required coverage.

§ 11.2 Owner's Insurance

§ 11.2.1 The Owner shall purchase and maintain insurance of the types and limits of liability, containing the endorsements, and subject to the terms and conditions, as described in the Agreement or elsewhere in the Contract Documents. The Owner shall purchase and maintain the required insurance from an insurance company or insurance companies lawfully authorized to issue insurance in Connecticut.

§ 11.2.2 Failure to Purchase Required Property Insurance. If the Owner does not intend to purchase and maintain the required property insurance, with all of the coverages and in the amounts described in the Agreement or elsewhere in the Contract Documents, the Owner shall inform the Contractor in writing prior to commencement of the Work. Upon receipt of notice from the Owner, the Contractor may delay commencement of the Work and may obtain insurance that will protect the interests of the Contractor, Subcontractors, and Sub-Subcontractors in the Work. When the failure to provide coverage has been cured or resolved, the Contract Sum and Contract Time shall be equitably adjusted. In the event the Owner fails to procure coverage, the Owner waives all rights against the Contractor, Subcontractors, and Sub-subcontractors to the extent the loss to the Owner would have been covered by the insurance to have been procured by the Owner. The cost of the insurance shall be charged to the Owner by a Change Order. If the Owner does not provide written notice, and the Contractor is damaged by the failure or neglect of the Owner to purchase or maintain the required insurance, the Owner shall reimburse the Contractor for all reasonable costs and damages attributable thereto.

§ 11.2.3 Notice of Cancellation or Expiration of Owner's Required Property Insurance. Within three (3) business days of the date the Owner becomes aware of an impending or actual cancellation or expiration of any property insurance required by the Contract Documents, the Owner shall provide notice to the Contractor of such impending or actual cancellation or expiration. Unless the lapse in coverage arises from an act or omission of the Contractor: (1) the Contractor, upon receipt of notice from the Owner, shall have the right to stop the Work until the lapse in coverage has been cured by the procurement of replacement coverage by either the Owner or the Contractor; (2) the Contract Time and Contract Sum shall be equitably adjusted; and (3) the Owner waives all rights against the Contractor, Subcontractors, and Sub-subcontractors to the extent any loss to the Owner would have been covered by the insurance had it not expired or been cancelled. If the Contractor purchases replacement coverage, the cost of the insurance shall be charged to the Owner by an appropriate Change Order. The furnishing of notice by the Owner shall not relieve the Owner of any contractual obligation to provide required insurance.

§ 11.3 Waivers of Subrogation

§ 11.3.1 The Owner and Contractor waive all rights against (1) each other and any of their subcontractors, sub-subcontractors, agents, and employees, each of the other; (2) the Architect and Architect's consultants; and (3) Separate Contractors, if any, and any of their subcontractors, sub-subcontractors, agents, and employees, for damages caused by fire, or other causes of loss, to the extent those losses are covered by property insurance required by the Agreement or other property insurance applicable to the Project, except such rights as they have to proceeds of such insurance. The Owner or Contractor, as appropriate, shall require similar written waivers in favor of the individuals and entities identified above from the Architect, Architect's consultants, Separate Contractors, subcontractors, and sub-subcontractors. The policies of insurance purchased and maintained by each person or entity agreeing to waive claims pursuant to this section 11.3.1 shall not prohibit this waiver of subrogation. This waiver of subrogation shall be effective as to a person or entity (1) even though that person or entity would otherwise have a duty of indemnification, contractual or otherwise, (2) even though that person or entity did not pay the insurance premium directly or indirectly, or (3) whether or not the person or entity had an insurable interest in the damaged property.

§ 11.3.2 If during the Project construction period the Owner insures properties, real or personal or both, at or adjacent to the site by property insurance under policies separate from those insuring the Project, or if after final payment property insurance is to be provided on the completed Project through a policy or policies other than those insuring

the Project during the construction period, to the extent permissible by such policies, the Owner waives all rights in accordance with the terms of Section 11.3.1 for damages caused by fire or other causes of loss covered by this separate property insurance.

§ 11.4 Loss of Use, Business Interruption, and Delay in Completion Insurance

The Owner, at the Owner's option, may purchase and maintain insurance that will protect the Owner against loss of use of the Owner's property, or the inability to conduct normal operations, due to fire or other causes of loss. The Owner waives all rights of action against the Contractor and Architect for loss of use of the Owner's property, due to fire or other hazards however caused.

§ 11.5 Adjustment and Settlement of Insured Loss

§ 11.5.1 A loss insured under the property insurance required by the Agreement shall be adjusted by the Owner as fiduciary and made payable to the Owner in good faith for the insureds, as their interests may appear, subject to requirements of any applicable mortgagee clause and of Section 11.5.2. The Owner shall pay the Architect and Contractor their just shares of insurance proceeds received by the Owner, and by appropriate agreements the Architect and Contractor shall make payments to their consultants and Subcontractors in similar manner.

§ 11.5.2 Prior to settlement of an insured loss, the Owner shall notify the Contractor of the terms of the proposed settlement as well as the proposed allocation of the insurance proceeds. The Contractor shall have 14 days from receipt of notice to object to the proposed settlement or allocation of the proceeds. If the Contractor does not object, the Owner shall settle the loss and the Contractor shall be bound by the settlement and allocation. Upon receipt, the Owner shall deposit the insurance proceeds in a separate account and make the appropriate distributions. Thereafter, if no other agreement is made or the Owner does not terminate the Contract for convenience, the Owner and Contractor shall execute a Change Order for reconstruction of the damaged or destroyed Work in the amount allocated for that purpose. If the Contractor timely objects to either the terms of the proposed settlement or the allocation of the proceeds, the Owner may proceed to settle the insured loss, and any dispute between the Owner and Contractor arising out of the settlement or allocation of the proceeds shall be resolved pursuant to Article 15. Pending resolution of any dispute, the Owner may issue a Construction Change Directive for the reconstruction of the damaged or destroyed Work.

ARTICLE 12 UNCOVERING AND CORRECTION OF WORK

§ 12.1 Uncovering of Work

§ 12.1.1 If a portion of the Work is covered contrary to the Architect's request or to requirements specifically expressed in the Contract Documents, it must, if requested in writing by the Architect, be uncovered for the Architect's examination and be replaced at the Contractor's expense without change in the Contract Time.

§ 12.1.2 If a portion of the Work has been covered that the Architect has not specifically requested to examine prior to its being covered, the Architect may request to see such Work and it shall be uncovered by the Contractor. If such Work is in accordance with the Contract Documents, the Contractor shall be entitled to an equitable adjustment to the Contract Sum and Contract Time as may be appropriate. If such Work is not in accordance with the Contract Documents, the costs of uncovering the Work, and the cost of correction, shall be at the Contractor's expense.

§ 12.2 Correction of Work

§ 12.2.1 Before Substantial Completion

The Contractor shall promptly and at its own expense correct Work rejected by the Architect or failing to conform to the requirements of the Contract Documents, discovered before Substantial Completion and whether or not fabricated, installed or completed. Costs of correcting such rejected Work, including additional testing and inspections, the cost of uncovering and replacement, and compensation for the Architect's services and expenses made necessary thereby, shall be at the Contractor's expense. This obligation shall survive termination of the Contract under Paragraph 14 of the General Conditions. Nothing in this Section 12.2.1 shall absolve the Architect of its liability for failure to fulfill its obligations under the agreement between the Owner and the Architect.

§ 12.2.2 After Substantial Completion

§ 12.2.2.1 In addition to the Contractor's obligations under Section 3.5, if, within one year after the date of Substantial Completion of the Work or designated portion thereof or after the date for commencement of warranties established under Section 9.9.1, or by terms of any applicable special warranty required by the Contract Documents,

any of the Work is found to be not in accordance with the requirements of the Contract Documents, the Contractor shall correct it promptly after receipt of notice from the Owner to do so, unless the Owner has previously given the Contractor a written acceptance of such condition. The Owner shall give such notice promptly after discovery of the condition. During the one-year period for correction of Work, if the Owner fails to notify the Contractor and give the Contractor an opportunity to make the correction, the Owner waives the rights to require correction by the Contractor and to make a claim for breach of warranty. If the Contractor fails to correct nonconforming Work within a reasonable time during that period after receipt of notice from the Owner or Architect, the Owner may correct it in accordance with Section 2.5.

§ 12.2.2.2 The one-year period for correction of Work shall be extended with respect to portions of Work first performed after Substantial Completion by the period of time between Substantial Completion and the actual completion of that portion of the Work.

§ 12.2.2.3 The one-year period for correction of Work shall not be extended by corrective Work performed by the Contractor pursuant to this Section 12.2.

§ 12.2.3 The Contractor shall remove from the site portions of the Work that are not in accordance with the requirements of the Contract Documents and are neither corrected by the Contractor nor accepted by the Owner.

§ 12.2.4 The Contractor shall bear the cost of correcting destroyed or damaged construction of the Owner or Separate Contractors, whether completed or partially completed, caused by the Contractor's correction or removal of Work that is not in accordance with the requirements of the Contract Documents.

§ 12.2.5 Nothing contained in this Section 12.2 shall be construed to establish a period of limitation with respect to other obligations the Contractor has under the Contract Documents. Establishment of the one-year period for correction of Work as described in Section 12.2.2 relates only to the specific obligation of the Contractor to correct the Work, and has no relationship to the time within which the obligation to comply with the Contract Documents may be sought to be enforced, nor to the time within which proceedings may be commenced to establish the Contractor's liability with respect to the Contractor's obligations other than specifically to correct the Work.

§ 12.2.6 AUDITS

Upon request of the Owner or the Architect, the Contractor will cooperate, and secure the cooperation of all Subcontractors and Sub-subcontractors, and assist the Owner, Architect, and the Department during any audit of the Project conducted by the Owner or the Department at any time after Substantial Completion.

§ 12.3 Acceptance of Nonconforming Work

If the Owner prefers to accept Work that is not in accordance with the requirements of the Contract Documents, the Owner may do so instead of requiring its removal and correction, in which case the Contract Sum will be reduced as appropriate and equitable. Such adjustment shall be effected whether or not final payment has been made.

ARTICLE 13 MISCELLANEOUS PROVISIONS

§ 13.1 Governing Law

The Contract shall be governed by the law of the State of Connecticut.

§ 13.2 Successors and Assigns

§ 13.2.1 The Owner and Contractor respectively bind themselves, their partners, successors, assigns, and legal representatives to covenants, agreements, and obligations contained in the Contract Documents. The Contractor may not assign the Contract without the Owner's prior written consent, which consent the Owner may withhold in its absolute discretion. If the Contractor attempts to make an assignment without such consent, the Contractor shall nevertheless remain legally responsible for all of the Contractor's obligations under the Contract.

§ 13.2.2 Contractor shall execute all consents reasonably required to facilitate an assignment by the Owner.

§ 13.3 Rights and Remedies

§ 13.3.1 Duties and obligations imposed by the Contract Documents and rights and remedies available thereunder shall be in addition to and not a limitation of duties, obligations, rights, and remedies otherwise imposed or available by law or in equity.

§ 13.3.2 No action or failure to act by the Owner, Architect, or Contractor shall constitute a waiver of a right or duty afforded them under the Contract, nor shall such action or failure to act constitute approval of or acquiescence in a breach thereunder, except as may be specifically agreed upon in writing.

§ 13.3.3 Submission by the Owner of a final grant application to the Department shall not constitute a waiver of any Claims by the Owner.

§ 13.3.4 No provision contained in the Contract Documents shall create or give to third parties any claim or right of action against the Owner or the Contractor except as specifically provided herein.

§ 13.4 Tests and Inspections

§ 13.4.1 Tests, inspections, certifications and approvals of portions of the Work shall be made as required by the Contract Documents and by the Conditions, applicable laws, statutes, ordinances, codes, rules, and regulations or lawful orders of public authorities. Unless otherwise provided, the Contractor shall make arrangements for such tests, inspections, and approvals with an independent testing laboratory or entity acceptable to the Owner, or with the appropriate public authority, and shall bear all related costs of tests, inspections, and approvals. The Contractor shall give the Architect timely notice of when and where tests and inspections are to be made so that the Architect may be present for such procedures. The Owner shall bear costs of tests, inspections, or approvals that do not become requirements until after bids are received or negotiations concluded. The Owner shall directly arrange and pay for tests, inspections, or approvals where building codes or applicable laws or regulations so require.

§ 13.4.2 If the Architect, Owner, or public authorities having jurisdiction determine that portions of the Work require additional testing, inspection, or approval not included under Section 13.4.1, the Architect will, upon written authorization from the Owner, instruct the Contractor to make arrangements for such additional testing, inspection, or approval, by an entity acceptable to the Owner, and the Contractor shall give timely notice to the Architect of when and where tests and inspections are to be made so that the Architect may be present for such procedures. Such costs, except as provided in Section 13.4.3 and 13.4.4, shall be at the Owner's expense.

§ 13.4.3 If inspections and tests conducted under this Section 13.4 reveal failure in a portion of the Work, the Owner may order the inspection and testing, at the Contractor's expense, of any and all portions of the Work that are identical or similar to the failing portion.

§ 13.4.4 Required certificates of testing, certification, inspection or approval shall, unless otherwise required by the Contract Documents, be secured by the Contractor and promptly delivered to the Architect.

§ 13.4.5 If the Architect is to observe tests, inspections, or approvals required by the Contract Documents, the Architect will do so promptly and, where practicable, at the normal place of testing.

§ 13.4.6 Tests or inspections conducted pursuant to the Contract Documents shall be made promptly to avoid unreasonable delay in the Work.

§ 13.5 Interest

INTENTIONALLY OMITTED

§ 13.6 Wherever possible, each provision of this Agreement shall be interpreted in a manner as to be effective and valid under applicable law. If, however, any provision of this Agreement, or portion thereof, is prohibited by law or found invalid under any law, only such provision or portion thereof shall be ineffective, without in any manner invalidating or affecting the remaining provisions of this Agreement or valid portion of such provision, which are hereby deemed severable.

§ 13.7 The parties expressly understand and agree that any provision in this Contract related to job site safety, supervision, inspections or compliance with ordinances, laws, statutes, rules, regulations and/or protocols are solely for the benefit of the Contractor and Owner and do not create any rights, claims, or causes of action in third parties, separate contractors, Subcontractors or Sub-subcontractors, or any of their employees performing work on or at the Project. Nothing in this Agreement is intended to confer any rights in any other contractor, Subcontractor of any tier material supplier, or their employees, as there are no intended third party beneficiaries of this Agreement.

§ 13.8 Each and every provision of law and clause required by law to be inserted in this contract shall be deemed to

be inserted herein and the contract shall be read and enforced as though it were included herein.

§ 13.9 If the Contractor is a "nonresident contractor" as defined in Section 12-430(7)(A) of the Connecticut General Statutes, as revised, the Contractor shall comply fully with the provisions of Section 12-430(7) and, prior to commencing the Work, shall furnish the Owner with a copy of the requisite certificate of compliance set forth in subparagraph (E) of Section 12-430(7). Contractor agrees to indemnify Owner as to any and all taxes, interest and penalties that the State of Connecticut asserts are due with respect to the Contractor's activities.

§ 13.10 Contractor shall comply with the requirements of Connecticut General Statutes Section 31-52. Specifically, Contractor agrees that in the employment of labor to perform the work specified herein, preference shall be given to citizens of the United States, who are, and continuously for at least three months prior to the date hereof have been, residents of the labor market area, as established by the Labor Commissioner, in which such work is to be done, and if no such qualified person is available, then to citizens who have continuously resided in the county in which the work is to be performed for at least three months prior to the date hereof, and then to citizens of the state who have continuously resided in the state at least three months prior to the date hereof.

§ 13.11 The wages paid on an hourly basis to any person performing the work of any mechanic, laborer or worker on the work herein contracted to be done and the amount of payment or contribution paid or payable on behalf of each such person to any employee welfare fund, as defined in Section 31-53 of the Connecticut General Statutes, shall be at a rate equal to the rate customary or prevailing for the same work in the same trade or occupation in the town in which such public works project is being constructed. Any contractor who is not obligated by agreement to make payment or contribution on behalf of such persons to any such employee welfare fund shall pay to each mechanic, laborer or worker as part of such person's wages the amount of payment or contribution for such person's classification on each pay day.

§ 13.12 Contractor and each of its Subcontractors shall furnish proof that each employee performing the work of a mechanic, laborer or worker on the Project has completed a course of at least ten (10) hours in construction safety and health approved by the federal Occupational Safety and Health Administration (OSHA) or has completed a new miner training program approved by the Federal Mine Safety and Health Administration. Such proof shall be provided with the certified payroll submitted for the first week each such employee, mechanic, laborer, or worker, begins work on the Project.

§ 13.13 Contractor hereby confirms that it has complied with the obligations under the Immigration Reform and Control Act (IRCA) and that the workers provided under this Agreement are authorized for employment in the United States. Contractor further confirms that it has properly completed I-9's for all of its workers assigned to the Project and that it will require each of its Subcontractors to confirm that they have properly completed I-9's for all of their workers assigned to the Project. Contractor agrees to indemnify, defend, and hold harmless the Owner in the event that any of the workers assigned to the Project are found not to be authorized to work under the law or in the event that there is a determination that the obligations set forth under IRCA, including the obligation to correctly prepare and maintain I-9s, have not been complied with, including but not limited to all damages, fines and penalties, punitive damages, attorneys' fees and costs.

§ 13.14 Since the Contractor was required to be prequalified by the Connecticut Department of Administrative Services in the bidding for this Project, in the event the surety assumes the contract or obtains a bid or bids for completion of the contract, the surety shall ensure that the contractor chosen to complete the contract is prequalified pursuant to section 4a-100 of the Connecticut General Statutes in the requisite classification and has the aggregate work capacity rating and single project limit necessary to complete the contract.

§ 13.15 Each payment application shall be accompanied by a statement showing the status of all pending Change Orders, pending Change Directives and approved changes to the Contract. Such statement shall identify the pending Change Orders and pending Change Directives, and shall include the date such Change Orders and Change Directives were initiated, additional cost and/or time associated with their performance and a description of any work completed. The Contractor shall require each of its Subcontractors and suppliers to include a similar statement with each of their payment applications or invoices.

ARTICLE 14 TERMINATION OR SUSPENSION OF THE CONTRACT

§ 14.1 Termination by the Contractor

§ 14.1.1 The Contractor may terminate the Contract if the Work is stopped for a period of 30 consecutive days through no act or fault of the Contractor, a Subcontractor, a Sub-subcontractor, their agents or employees, or any other persons or entities performing portions of the Work, for any of the following reasons:

- .1 Issuance of an order of a court or other public authority having jurisdiction that requires all Work to be stopped;
- .2 An act of government, such as a declaration of national emergency, that requires all Work to be stopped; or
- .3 Because the Architect has not issued a Certificate for Payment and has not notified the Contractor of the reason for withholding certification as provided in Section 9.4.1, or because the Owner has not made payment on a Certificate for Payment within the time stated in the Contract Documents and has not notified the Contractor of the reason for withholding payment.

§ 14.1.2 The Contractor may terminate the Contract if, through no act or fault of the Contractor, a Subcontractor, a Sub-subcontractor, their agents or employees, or any other persons or entities performing portions of the Work, repeated suspensions, delays, or interruptions of the entire Work by the Owner as described in Section 14.3, constitute in the aggregate more than 100 percent of the total number of days scheduled for completion, or 120 days in any 365-day period, whichever is less.

§ 14.1.3 If one of the reasons described in Section 14.1.1 or 14.1.2 exists, the Contractor may, upon thirty (30) additional days' notice to the Owner and Architect, terminate the Contract and recover from the Owner payment for Work executed, as well as reasonable overhead and profit on Work not executed, and costs incurred by reason of such termination. The notice of termination must state with specificity the means by which the Owner may cure its nonperformance, and the Contractor shall not terminate this Agreement if, within thirty (30) days of the notice, the Owner substantially undertakes such curative measures.

§ 14.1.4 INTENTIONALLY OMITTED

§ 14.2 Termination by the Owner for Cause

§ 14.2.1 The Owner may, without prejudice to any right or remedy available to the Owner under the Contract Documents or at law or in equity terminate the Contract if the Contractor:

- .1 institutes proceedings or consents to proceedings requesting relief or arrangement under the Federal Bankruptcy Act or any similar or applicable Federal or state law, or if a petition under any Federal or state bankruptcy or insolvency law is filed against the Contractor and such petition is not dismissed within sixty (60) days from the date of said filing, or if the Contractor admits in writing its inability to pay its debts generally as they become due, or if it makes a general assignment for the benefit of its creditors, or if a receiver, liquidator, trustee or assignee is appointed on account of bankruptcy or insolvency; or if a receiver of all or any substantial portion of the Contractor's properties is appointed;
- .2 abandons the Work; or if it fails, except in cases for which extension of time prosecute promptly and diligently the Work;
- .3 fails to supply enough properly skilled workers or proper materials for the Work;
- .4 submits an Application for Payment, sworn statement, waiver of lien, affidavit or document of any nature whatsoever which is intentionally falsified;
- .5 fails to make payment to Subcontractors for materials or labor in accordance with the Contract Documents and the respective agreements between the Contractor and the Subcontractors;
- .6 disregards the Conditions, applicable laws, statutes, ordinances, codes; rules and regulations, or lawful orders of a public and appropriate authority;
- .7 otherwise is guilty of substantial breach of a provision of the Contract Documents or
- .8 if a mechanic's or materialmen's lien or notice of lien is filed against any part of the Work or the site of the Project and not promptly bonded or insured over by the Contractor after the receipt of notice thereof in a manner reasonably satisfactory to the Owner.

§ 14.2.2 When any of the reasons described in Section 14.2.1 exist, may, without prejudice to any other rights or remedies of the Owner and after giving the Contractor and the Contractor's surety, if any, seven days' notice, terminate employment of the Contractor and may, subject to any prior rights of the surety:

- .1 Exclude the Contractor from the site and take possession of all materials, equipment, tools, and construction equipment and machinery thereon owned by the Contractor;
- .2 Accept assignment of subcontracts pursuant to Section 5.4; and
- .3 Finish the Work by whatever reasonable method the Owner may deem expedient. Upon written request of the Contractor, the Owner shall furnish to the Contractor a detailed accounting of the costs incurred by the Owner in finishing the Work.

§ 14.2.3 When the Owner terminates the Contract for one of the reasons stated in Section 14.2.1, the Contractor shall not be entitled to receive further payment until the Work is finished.

§ 14.2.4 If the unpaid balance of the Contract Sum exceeds costs of finishing the Work, including compensation for the Architect's services and expenses made necessary thereby, and other damages incurred by the Owner and not expressly waived, such excess shall be paid to the Contractor. If such costs and damages exceed the unpaid balance, the Contractor shall pay the difference to the Owner. The amount to be paid to the Contractor or Owner, as the case may be, shall be certified by the Initial Decision Maker, upon application, and this obligation for payment shall survive termination of the Contract.

§ 14.2.5 If the Owner terminates the Contractor for cause and it is thereafter determined that the Owner did not have the right to terminate the Contractor for cause, such termination for cause shall automatically be converted into a termination for convenience under Article 14.4 hereto.

§ 14.3 Suspension by the Owner for Convenience

§ 14.3.1 The Owner may, without cause, order the Contractor in writing to suspend, delay or interrupt the Work, in whole or in part for such period of time as the Owner may determine.

§ 14.3.2 The Contract Sum and Contract Time shall be adjusted for increases in the cost and time caused by suspension, delay, or interruption under Section 14.3.1. Adjustment of the Contract Sum shall include profit. No adjustment shall be made to the extent

- .1 that performance is, was, or would have been, so suspended, delayed, or interrupted, by another cause for which the Contractor is responsible; or
- .2 that an equitable adjustment is made or denied under another provision of the Contract.

§ 14.4 Termination by the Owner for Convenience

§ 14.4.1 The Owner may, at any time, terminate the Contract for the Owner's convenience and without cause.

§ 14.4.2 Upon receipt of notice from the Owner of such termination for the Owner's convenience, the Contractor shall

- .1 cease operations as directed by the Owner in the notice;
- .2 take actions necessary, or that the Owner may direct, for the protection and preservation of the Work; and
- .3 except for Work directed to be performed prior to the effective date of termination stated in the notice, terminate all existing subcontracts and purchase orders and enter into no further subcontracts and purchase orders.

§ 14.4.3 Upon such termination, the Contractor shall recover as its sole remedy payment for Work properly performed in connection with the terminated portion of the Work prior to the effective date of termination and for items properly and timely fabricated off the Project site, delivered and stored in accordance with the Owner's instructions. The Contractor hereby waives and forfeits all other claims for payment and damages, including, without limitation, anticipated profits and consequential damages. The Owner shall be credited for (i) payments previously made to the Contractor for the terminated portion of the Work, (ii) claims that the Owner has against the Contractor under the Contract, and (iii) the value of the materials, supplies, equipment, or other items that are to be disposed of by the Contractor that are part of the Contract Sum

ARTICLE 15 CLAIMS AND DISPUTES

§ 15.1 Claims

§ 15.1.1 Definition

A Claim is a demand or assertion by one of the parties seeking, as a matter of right, payment of money, a change in the Contract Time, or other relief with respect to the terms of the Contract. The term "Claim" also includes other disputes and matters in question between the Owner and Contractor arising out of or relating to the Contract. The responsibility to substantiate Claims shall rest with the party making the Claim. This Section 15.1.1 does not require the Owner to file a Claim in order to impose liquidated damages in accordance with the Contract Documents. Failure to give such timely written notice will bar any claims by the Contractor. The Owner's prior written consent to proceed with any Work for which the Contractor will claim it is entitled to additional compensation is a condition precedent to recovery for such work. Any notice of Claim must clearly identify the alleged cause and the nature of the Claim and include date and information then available to the claimant that will facilitate prompt verification and evaluation of the Claim.

§ 15.1.2 Time Limits on Claims

The Owner and Contractor shall commence all Claims and causes of action against the other and arising out of or related to the Contract, whether in contract, tort, breach of warranty or otherwise, in accordance with the requirements of the binding dispute resolution method selected in the Agreement and within the period specified by applicable law, but in any case not more than 10 years after the date of Substantial Completion of the Work. The Owner and Contractor waive all Claims and causes of action not commenced in accordance with this Section 15.1.2.

§ 15.1.3 Notice of Claims

§ 15.1.3.1 Claims by either the Owner or Contractor, where the condition giving rise to the Claim is first discovered prior to expiration of the period for correction of the Work set forth in Section 12.2.2, shall be initiated by notice to the other party and to the Initial Decision Maker with a copy sent to the Architect, if the Architect is not serving as the Initial Decision Maker. Claims by either party under this Section 15.1.3.1 shall be initiated within 21 days after occurrence of the event giving rise to such Claim or within 21 days after the claimant first recognizes the condition giving rise to the Claim, whichever is later.

§ 15.1.3.2 Claims by either the Owner or Contractor, where the condition giving rise to the Claim is first discovered after expiration of the period for correction of the Work set forth in Section 12.2.2, shall be initiated by notice to the other party. In such event, no decision by the Initial Decision Maker is required.

§ 15.1.4 Continuing Contract Performance

§ 15.1.4.1 Pending final resolution of a Claim, except as otherwise agreed in writing or as provided in Section 9.7 and Article 14, the Contractor shall proceed diligently with performance of the Contract and the Owner shall continue to make payments in accordance with the Contract Documents.

§ 15.1.4.2 The Contract Sum and Contract Time shall be adjusted in accordance with the Initial Decision Maker's decision, subject to the right of either party to proceed in accordance with this Article 15. The Architect will issue Certificates for Payment in accordance with the decision of the Initial Decision Maker.

§ 15.1.5 Claims for Additional Cost

If the Contractor wishes to make a Claim for an increase in the Contract Sum, notice as provided in Section 15.1.3 shall be given before proceeding to execute the portion of the Work that is the subject of the Claim. Prior notice is not required for Claims relating to an emergency endangering life or property arising under Section 10.4.

§ 15.1.6 Claims for Additional Time

§ 15.1.6.1 If the Contractor wishes to make a Claim for an increase in the Contract Time, written notice as provided herein shall be given. The Contractor's Claim shall include an estimate of cost and of probable effect of delay on progress of the Work. The Contractor shall have the burden of demonstrating the effect of the claimed delay on the Contract Time, and shall furnish the Owner and the Architect with such documentation relating thereto as the Owner and the Architect may reasonably require. In the case of a continuing delay, only one Claim is necessary.

§ 15.1.6.2 If adverse weather conditions are the basis for a Claim for additional time, such Claim shall be documented by data substantiating that weather conditions were abnormal for the period of time, could not have been reasonably anticipated, and had an adverse effect on the scheduled construction.

§ 15.1.7 Waiver of Claims for Consequential Damages

INTENTIONALLY OMITTED

§ 15.1.6 LIQUIDATED DAMAGES

It is mutually agreed that if the Contractor fails to substantially complete the Work by _____, 20__, the Owner will be damaged; and because the amount of the Owner's damages is difficult if not impossible to definitely ascertain and prove, it is hereby agreed that the amount of such damages shall be One Thousand Five Hundred Dollars (\$1,500) for each Day, or part thereof, of delay in substantially completing the Work. The Contractor agrees that said sum shall be deducted from monies due the Contractor under the Contract, or, if no money is due the Contractor, the Contractor hereby agrees to pay the Owner as liquidated damages, and not by way of penalty, such total sum as shall be due for such delay.

§ 15.2 Initial Decision

§ 15.2.1 Claims, excluding those where the condition giving rise to the Claim is first discovered after expiration of the period for correction of the Work set forth in Section 12.2.2 or arising under Sections 10.3, 10.4, and 11.5, shall be referred to the Initial Decision Maker for initial decision. The Architect will serve as the Initial Decision Maker, unless otherwise indicated in the Agreement. Except for those Claims excluded by this Section 15.2.1, an initial decision shall be required as a condition precedent to mediation of any Claim. If an initial decision has not been rendered within 30 days after the Claim has been referred to the Initial Decision Maker, the party asserting the Claim may demand mediation and binding dispute resolution without a decision having been rendered. Unless the Initial Decision Maker and all affected parties agree, the Initial Decision Maker will not decide disputes between the Contractor and persons or entities other than the Owner.

§ 15.2.2 The Initial Decision Maker will review Claims and within ten days of the receipt of a Claim take one or more of the following actions: (1) request additional supporting data from the claimant or a response with supporting data from the other party, (2) reject the Claim in whole or in part, (3) approve the Claim, (4) suggest a compromise, or (5) advise the parties that the Initial Decision Maker is unable to resolve the Claim if the Initial Decision Maker lacks sufficient information to evaluate the merits of the Claim or if the Initial Decision Maker concludes that, in the Initial Decision Maker's sole discretion, it would be inappropriate for the Initial Decision Maker to resolve the Claim.

§ 15.2.3 In evaluating Claims, the Initial Decision Maker may, but shall not be obligated to, consult with or seek information from either party or from persons with special knowledge or expertise who may assist the Initial Decision Maker in rendering a decision. The Initial Decision Maker may request the Owner to authorize retention of such persons at the Owner's expense.

§ 15.2.4 If the Initial Decision Maker requests a party to provide a response to a Claim or to furnish additional supporting data, such party shall respond, within ten days after receipt of the request, and shall either (1) provide a response on the requested supporting data, (2) advise the Initial Decision Maker when the response or supporting data will be furnished, or (3) advise the Initial Decision Maker that no supporting data will be furnished. Upon receipt of the response or supporting data, if any, the Initial Decision Maker will either reject or approve the Claim in whole or in part.

§ 15.2.5 The Initial Decision Maker will render an initial decision approving or rejecting the Claim, or indicating that the Initial Decision Maker is unable to resolve the Claim. This initial decision shall (1) be in writing; (2) state the reasons therefor; and (3) notify the parties and the Architect, if the Architect is not serving as the Initial Decision Maker, of any change in the Contract Sum or Contract Time or both. The initial decision shall be final and binding on the parties but subject to mediation and, if the parties fail to resolve their dispute through mediation, to binding dispute resolution.

§ 15.2.6 Either party may file for mediation of an initial decision at any time, subject to the terms of Section 15.2.6.1.

§ 15.2.6.1 Either party may, within 30 days from the date of receipt of an initial decision, demand in writing that the other party file for mediation. If such a demand is made and the party receiving the demand fails to file for mediation within 30 days after receipt thereof, then both parties waive their rights to mediate or pursue binding dispute resolution proceedings with respect to the initial decision.

§ 15.2.7 In the event of a Claim against the Contractor, the Owner may, but is not obligated to, notify the surety, if any, of the nature and amount of the Claim. If the Claim relates to a possibility of a Contractor's default, the Owner may, but is not obligated to, notify the surety and request the surety's assistance in resolving the controversy.

§ 15.3 Mediation

§ 15.3.1 Claims, disputes, or other matters in controversy arising out of or related to the Contract, except those waived as provided for in Sections 9.10.4 shall be subject to mediation as a condition precedent to binding dispute resolution.

§ 15.3.2 The parties shall endeavor to resolve their Claims by mediation which, unless the parties mutually agree otherwise, shall be administered by the American Arbitration Association in accordance with its Construction Industry Mediation Procedures in effect on the date of the Agreement. A request for mediation shall be made in writing, delivered to the other party to the Contract, and filed with the person or entity administering the mediation. The request may be made concurrently with the filing of binding dispute resolution proceedings but, in such event, mediation shall proceed in advance of binding dispute resolution proceedings, which shall be stayed pending mediation for a period of 60 days from the date of filing, unless stayed for a longer period by agreement of the parties or court order. If an arbitration is stayed pursuant to this Section 15.3.2, the parties may nonetheless proceed to the selection of the arbitrator(s) and agree upon a schedule for later proceedings.

§ 15.3.3 Either party may, within 30 days from the date that mediation has been concluded without resolution of the dispute or 60 days after mediation has been demanded without resolution of the dispute, demand in writing that the other party file for binding dispute resolution. If such a demand is made and the party receiving the demand fails to file for binding dispute resolution within 60 days after receipt thereof, then both parties waive their rights to binding dispute resolution proceedings with respect to the initial decision.

§ 15.3.4 The parties shall share the mediator's fee and any filing fees equally. The mediation shall be held in the place where the Project is located, unless another location is mutually agreed upon. Agreements reached in mediation shall be enforceable as settlement agreements in any court having jurisdiction thereof.

§ 15.4 Arbitration

§ 15.4.1. All claims, disputes and other matters in question between the Owner and the Contractor arising out of or related to the Contract or the breach thereof, except for claims which have been waived by the making and acceptance of final payments, shall be decided, at the sole option of the Owner, by one of the following dispute resolution procedures: (1) arbitration in accordance with rules agreed to by the Owner and the Contractor, (2) arbitration in accordance with the Construction Industry Arbitration Rules of the American Arbitration Association then obtaining, or (3) litigation.

§ 15.4.1.1 INTENTIONALLY OMITTED § 15.4.2 If a demand for arbitration is filed by the Contractor, the Owner will advise the Contractor within thirty days after the receipt of such a demand for arbitration if the Owner elects to arbitrate or rejects arbitration; such election, once made, shall be binding. The filing of a demand for arbitration by the Owner shall be deemed an election to arbitrate and shall constitute the exercise of the option of the Owner to proceed with arbitration. The Owner, but not the Contractor, may join or consolidate with any arbitration with the Contractor any disputes with the Architect, any Subcontractor, or any other party having an interest in the proceeding. This agreement to arbitrate shall be specifically enforceable under applicable law in any court having jurisdiction thereof. The award rendered by the arbitrator or arbitrators shall be final and judgment may be entered upon it in accordance with the applicable law in any court having jurisdiction thereof § 15.4.3 The Contractor agrees to continue performance of the Contract Work and shall proceed in accordance with the directives of the Owner, under protest, in the event of a dispute or controversy. Failure to so proceed shall constitute a material breach of the Contract, regardless of the ultimate decision on the dispute, it being understood and agreed that any controversy between the parties shall not be deemed a basis to delay or suspend the Contract Work, unless directed otherwise by the Owner.

§ 15.4.4 Consolidation or Joinder

§ 15.4.4.1 INTENTIONALLY OMITTED § 15.4.4.2 INTENTIONALLY OMITTED § 15.4.4.3 INTENTIONALLY OMITTED

NOTES:

APPLICABLE CODES :

The 2018 SBC adopts the following model codes:

- • 2015 International Building Code
- • 2015 International Existing Building Code
- • 2015 International Plumbing Code
- • 2015 International Mechanical Code
- • 2015 International Energy Conservation Code
- • 2017 National Electrical Code (NFPA 70)
- • 2009 ICC A117.1 Accessible and Usable Buildings & Facilities
- 2018 Connecticut State Fire Safety Code

ALL WORK FOR THIS PROJECT SHALL COMPLY WITH ALL APPLICABLE LOCAL, STATE AND FEDERAL CODES.

LOCATION MAP:

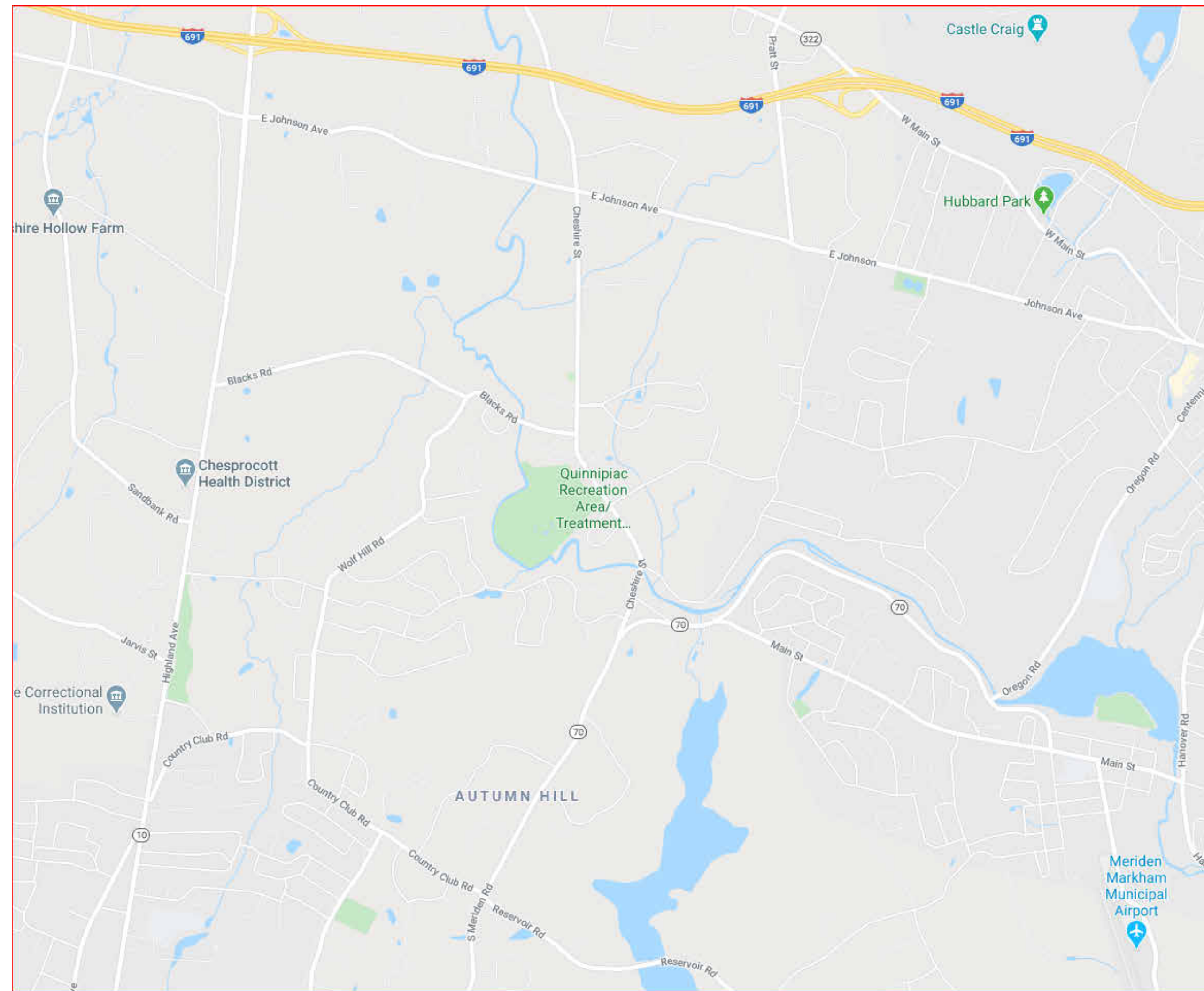

3/4/2022 4:37:35 AM



RENOVATION TO EXISTING BATHROOM AT QUINNIPIAC PARK 1325 CHESHIRE STREET, CHESHIRE, CT

CONSTRUCTION DOCUMENTS #2122-10

March 7, 2022

DRAWING LIST:

- .. COVER
- ..
- A1 BATHROOM PLANS, SECTIONS AND ELEVATIONS
- A2 HANDICAP SIGNS AND ACCESSORIES
-
- P1 QUINNIPIAC PARK PLUMBING DEMOLITION AND PROPOSED PLUMBING PLANS
- P2 PLUMBING SCHEDULES, DETAILS, SYMBOLS, NOTES AND ABBREVIATIONS
-
- ME1 QUINNIPIAC PARK MECHANICAL/ELECTRICAL DEMOLITION AND PROPOSED PLANS
- ME2 ELECTRICAL SCHEDULES, DETAILS, SYMBOLS, NOTES AND ABBREVIATIONS

REVISIONS:

No.	Revisions Description	Date

ARCHITECT:



WOJAS.ARCH, LLC

5 Race Track Hollow
Middlefield, CT 06455-1272
Phone: 860-930-5322
Fax: 860-349-2351
Email: wojas.arch@comcast.net

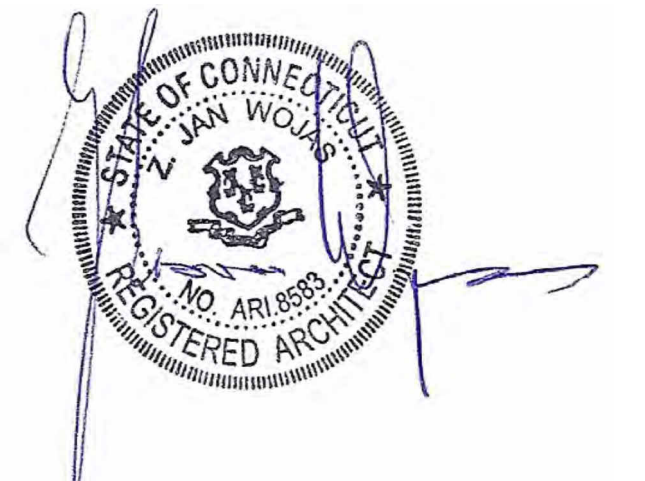

MEP ENGINEERS:

SALAMONE & ASSOCIATES, P.C.
CONSULTING ENGINEERS
116 North Plains Industrial Road
Wallingford, CT 06492
203-281-6895 fax 203-297-8728

RENOVATION TO EXISTING BATHROOM AT QUINNIPIAC PARK

QUINNIPIAC PARK, 1325 CHESHIRE STREET, CHESHIRE, CT

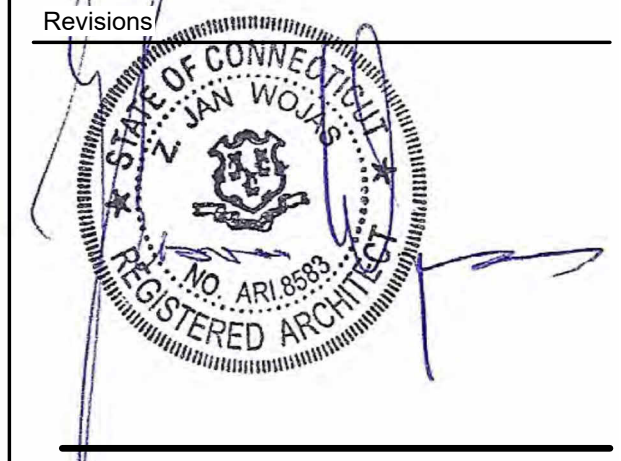

WOJAS.ARCH, LLC

5 Race Track Hollow
Middlefield, CT 06455
Phone: 860-630-5322
www.wojas.us
email: jan@wojas.us

**BATHROOM PLANS,
SECTIONS AND
ELEVATIONS**

PROJ. NO. 2122-10
DRAWING NO. **A1**
SCALE: As indicated
DATE: 3/7/2022

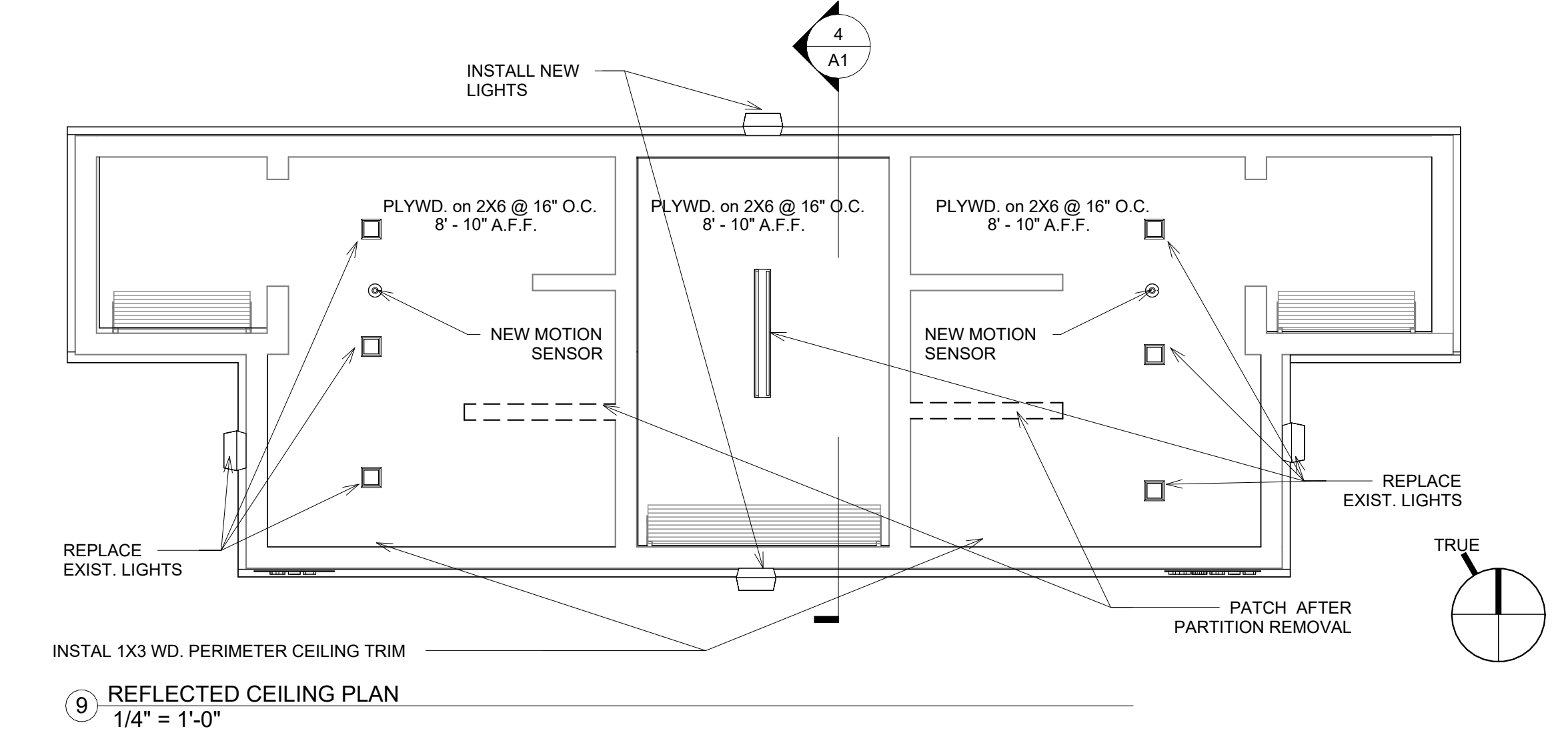
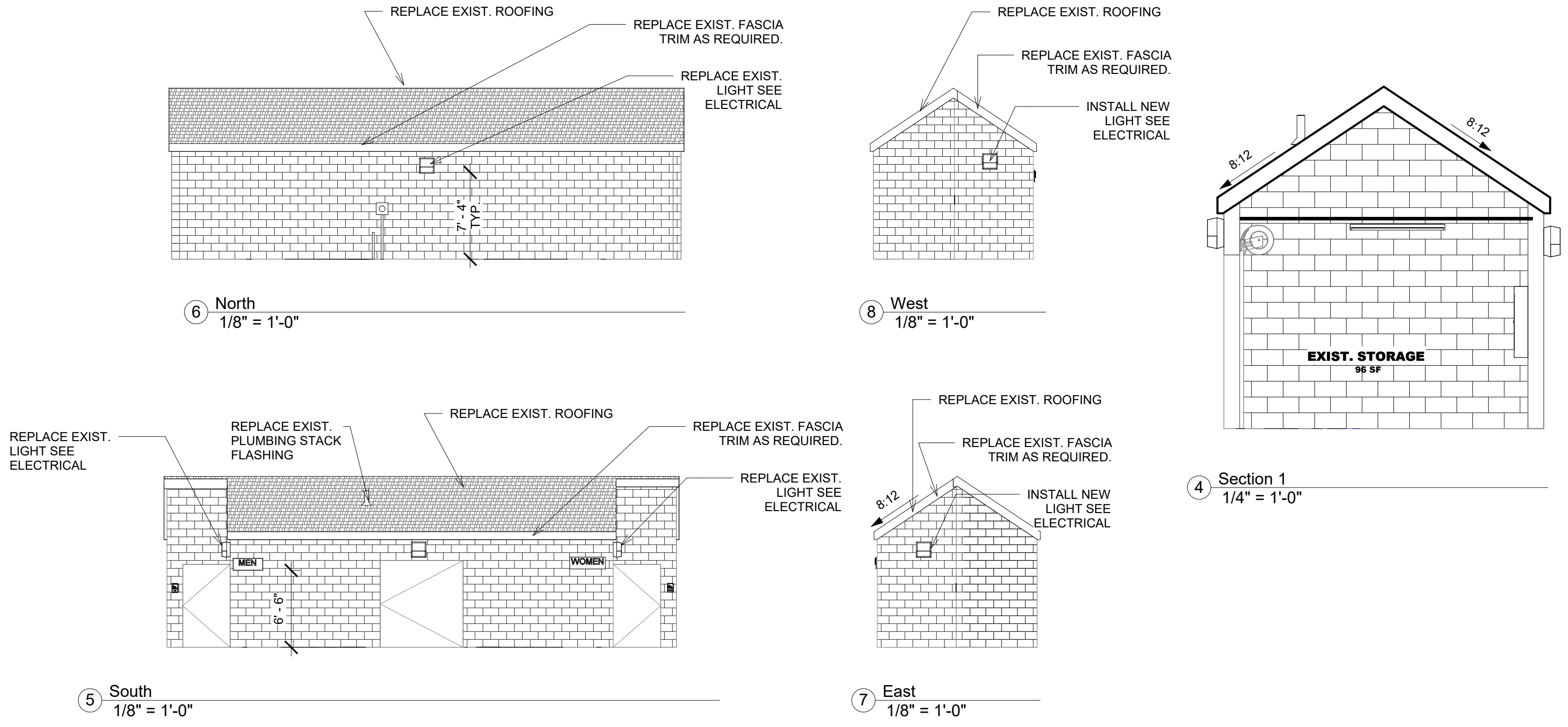

NOTES:

- SHOULD A CONTRACTOR FIND DISCREPANCIES OR AMBIGUITIES IN OR OMISSIONS FROM THE DRAWINGS OR TO BE IN DOUBT ABOUT THEIR MEANING, HE SHALL NOTIFY THE ARCHITECT IMMEDIATELY.
- CONTRACTOR SHALL VERIFY ALL DIMENSIONS ON THE JOB DURING THE CONSTRUCTION LAYOUT AND ADVISE THE ARCHITECT OF ANY DISCREPANCIES PRIOR TO PERFORMING ANY WORK
- DIMENSIONS ARE TO FACE OF MASONRY.

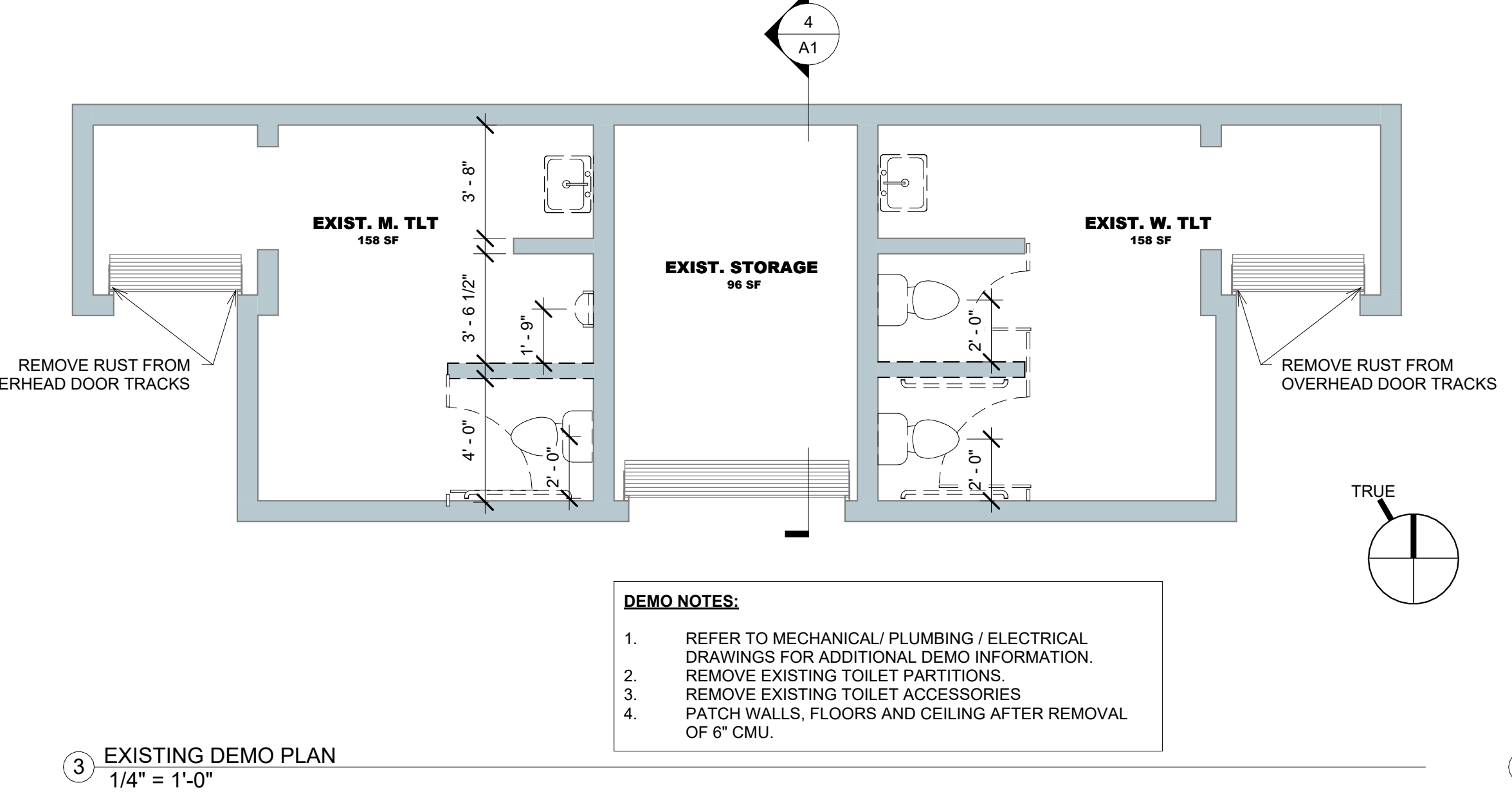

DEMO NOTES:

- REFER TO MECHANICAL / PLUMBING / ELECTRICAL DRAWINGS FOR ADDITIONAL DEMO INFORMATION.
- REMOVE EXISTING TOILET PARTITIONS.
- REMOVE EXISTING TOILET ACCESSORIES
- PATCH WALLS, FLOORS AND CEILING AFTER REMOVAL OF 6" CMU.

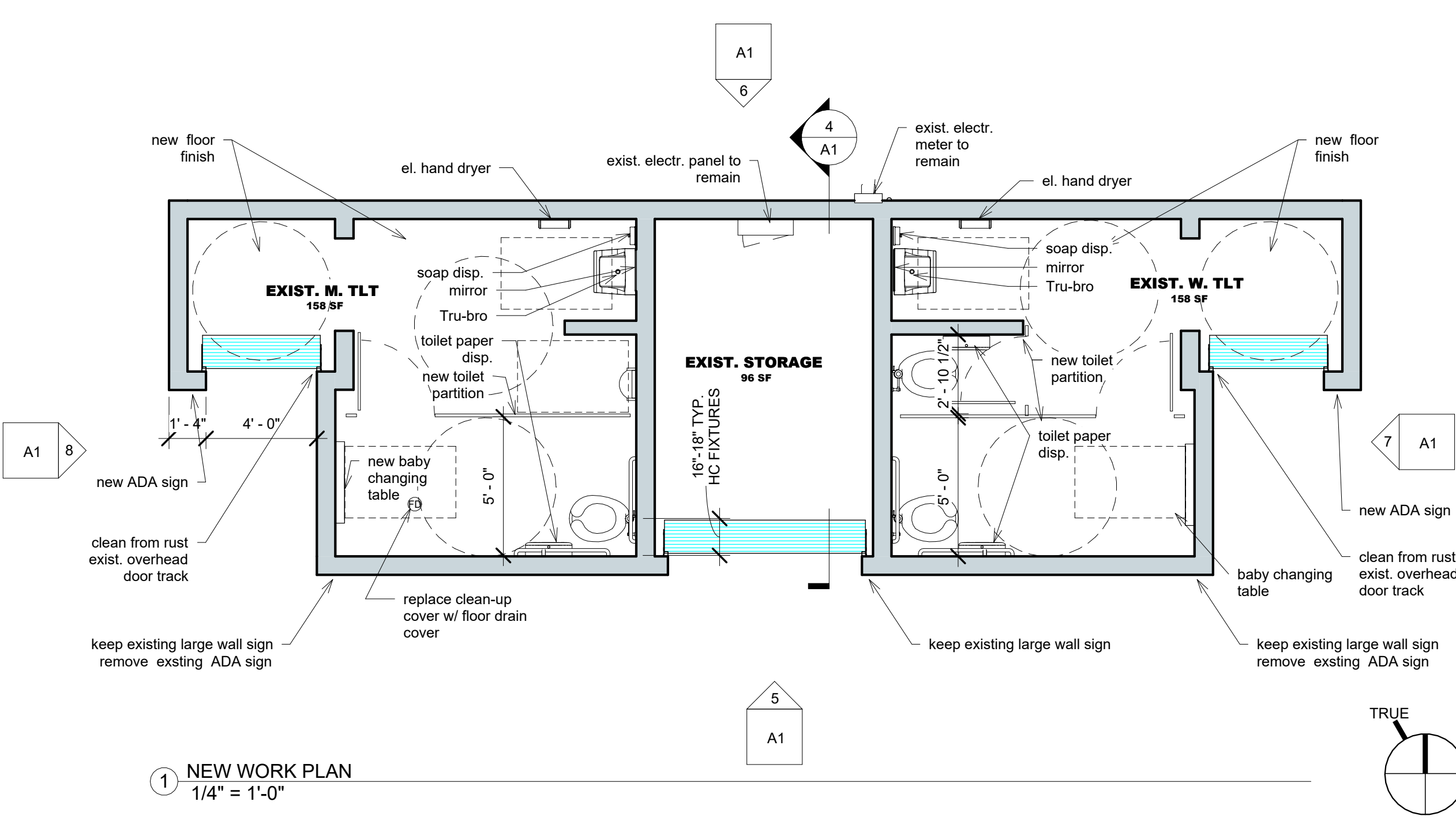
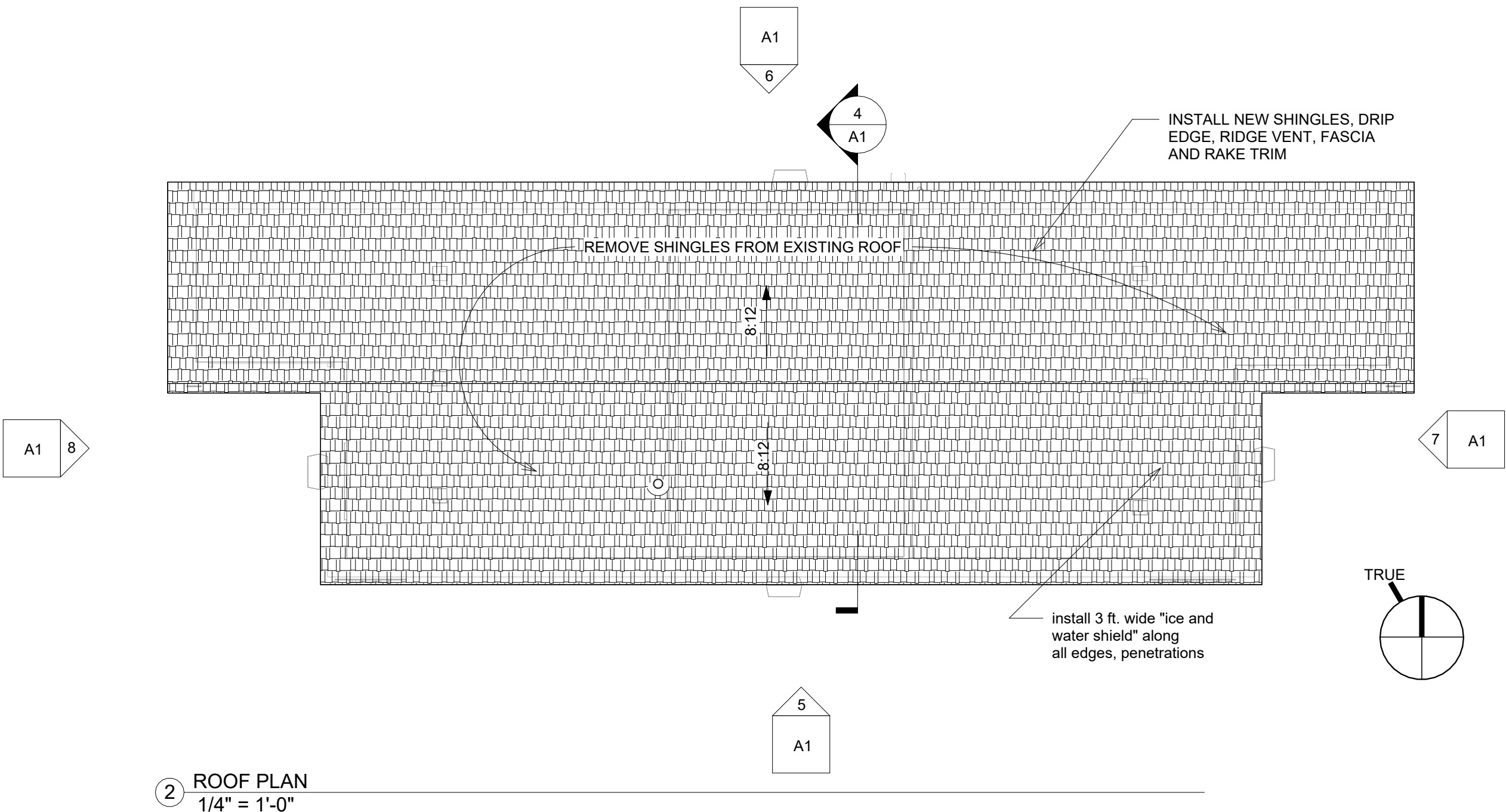
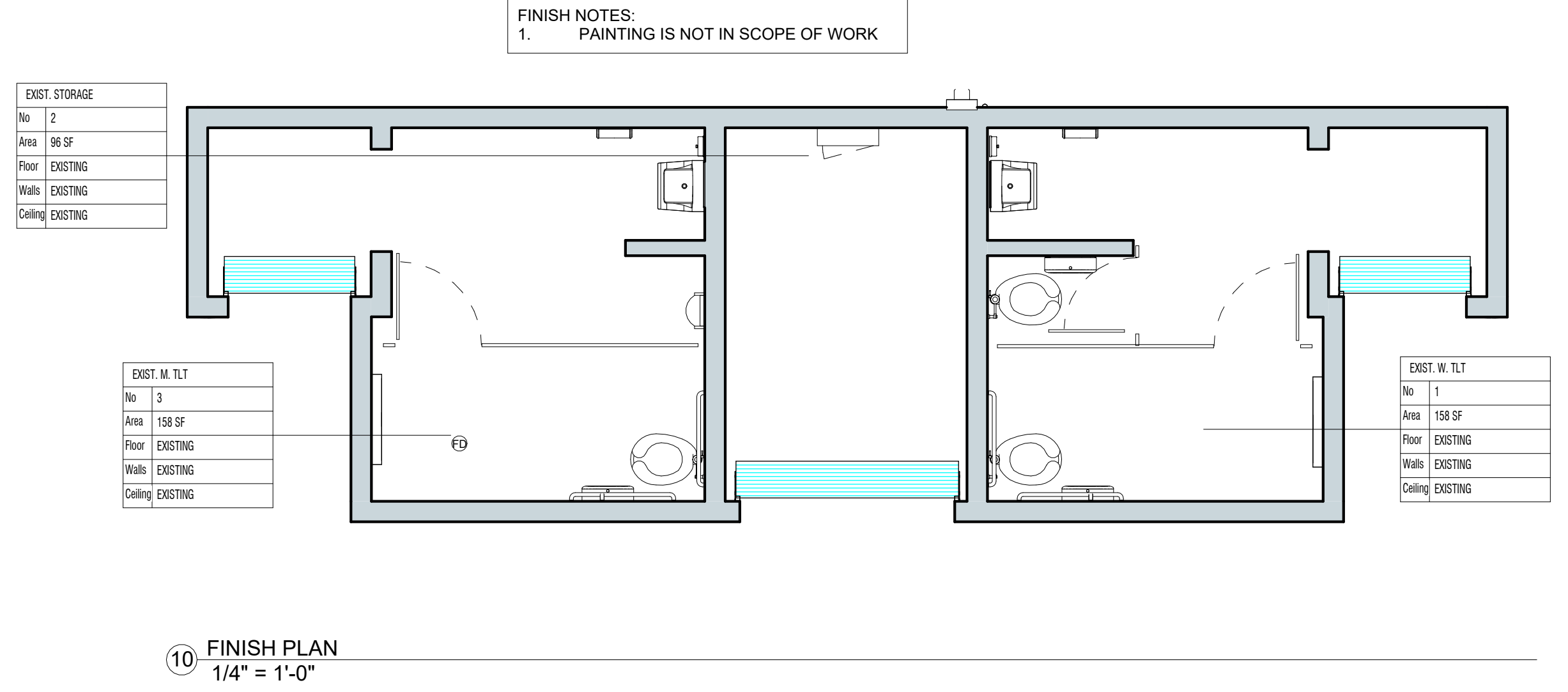
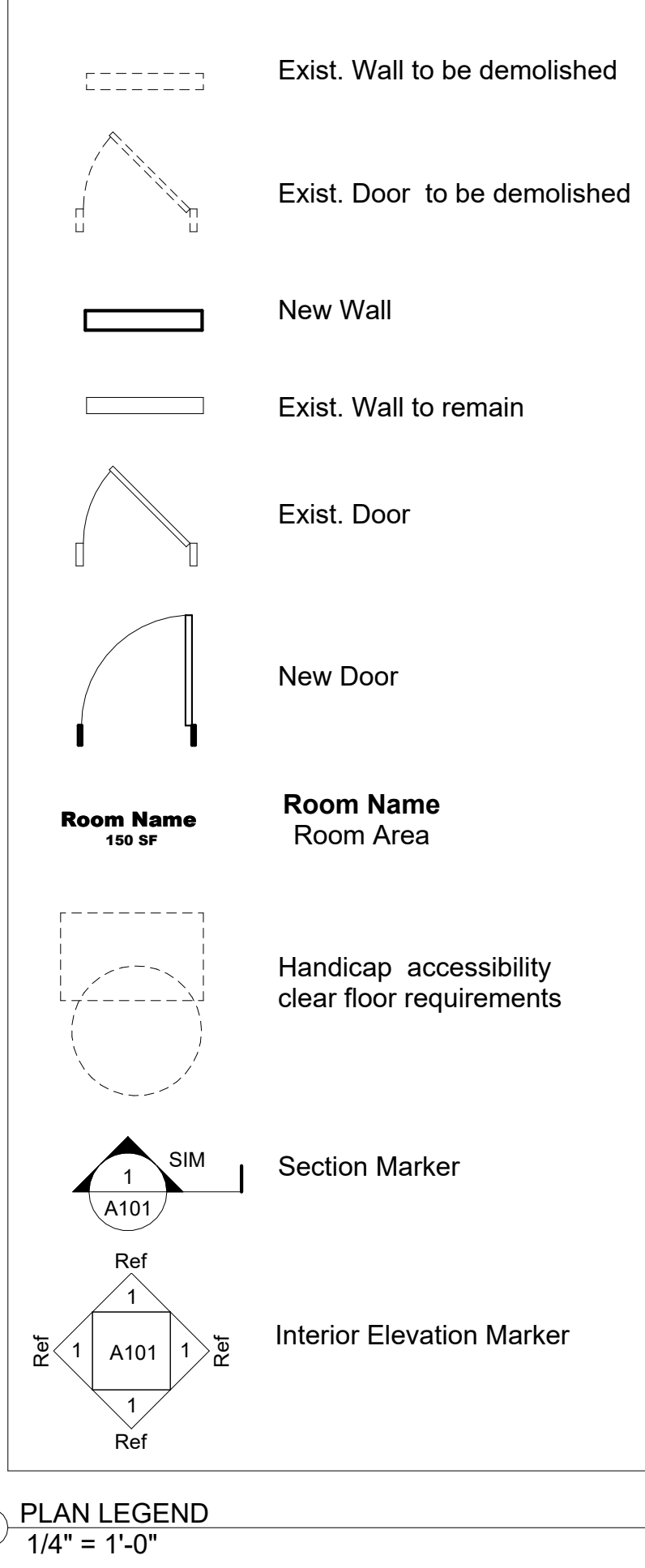
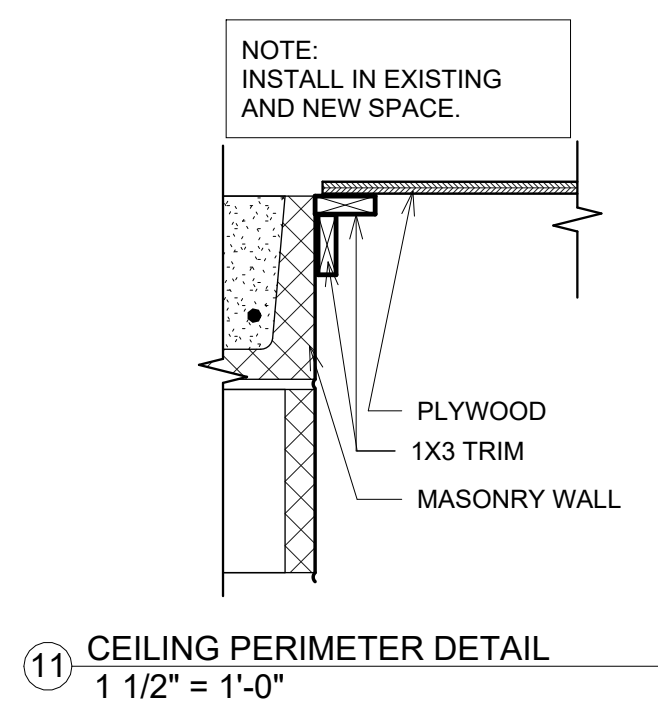

3/4/2022 4:40:29 AM

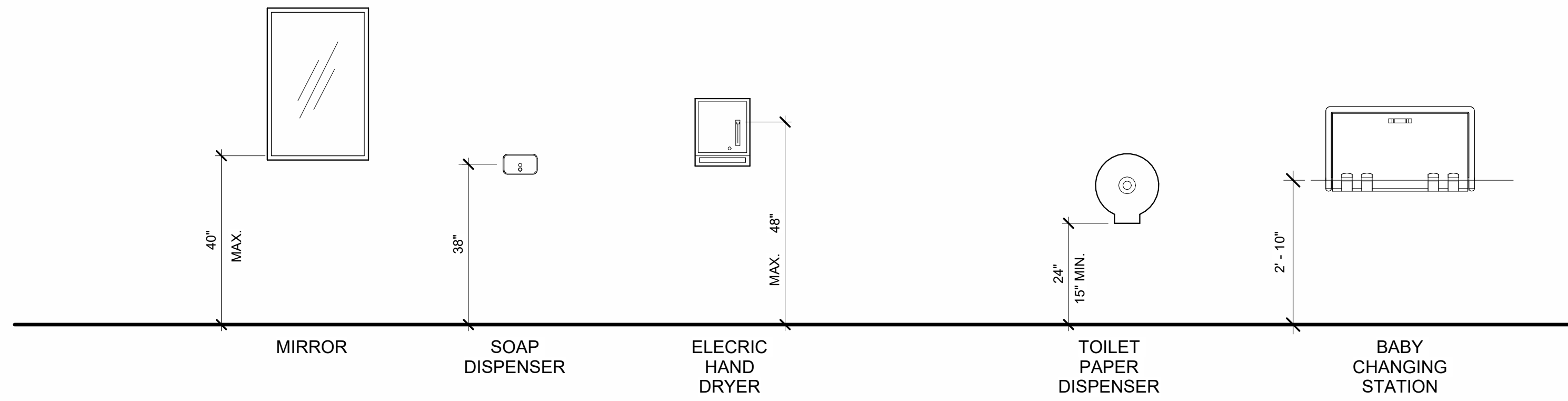

TYPICAL TOILET ACCESSORIES MOUNTING HEIGHTS

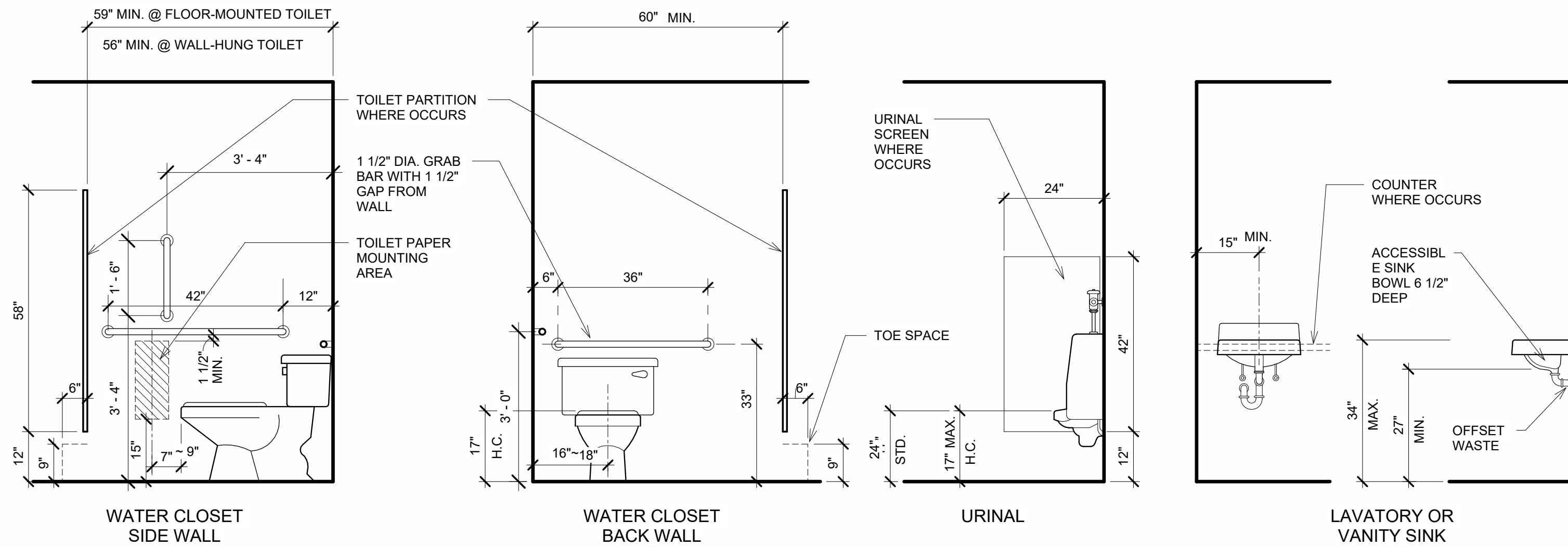

TYPICAL PLUMBING FIXTURES AND ACCESSORIES MOUNTING HEIGHTS

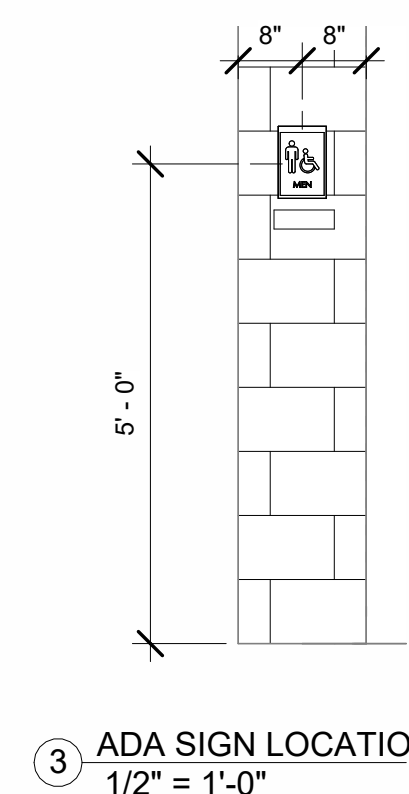
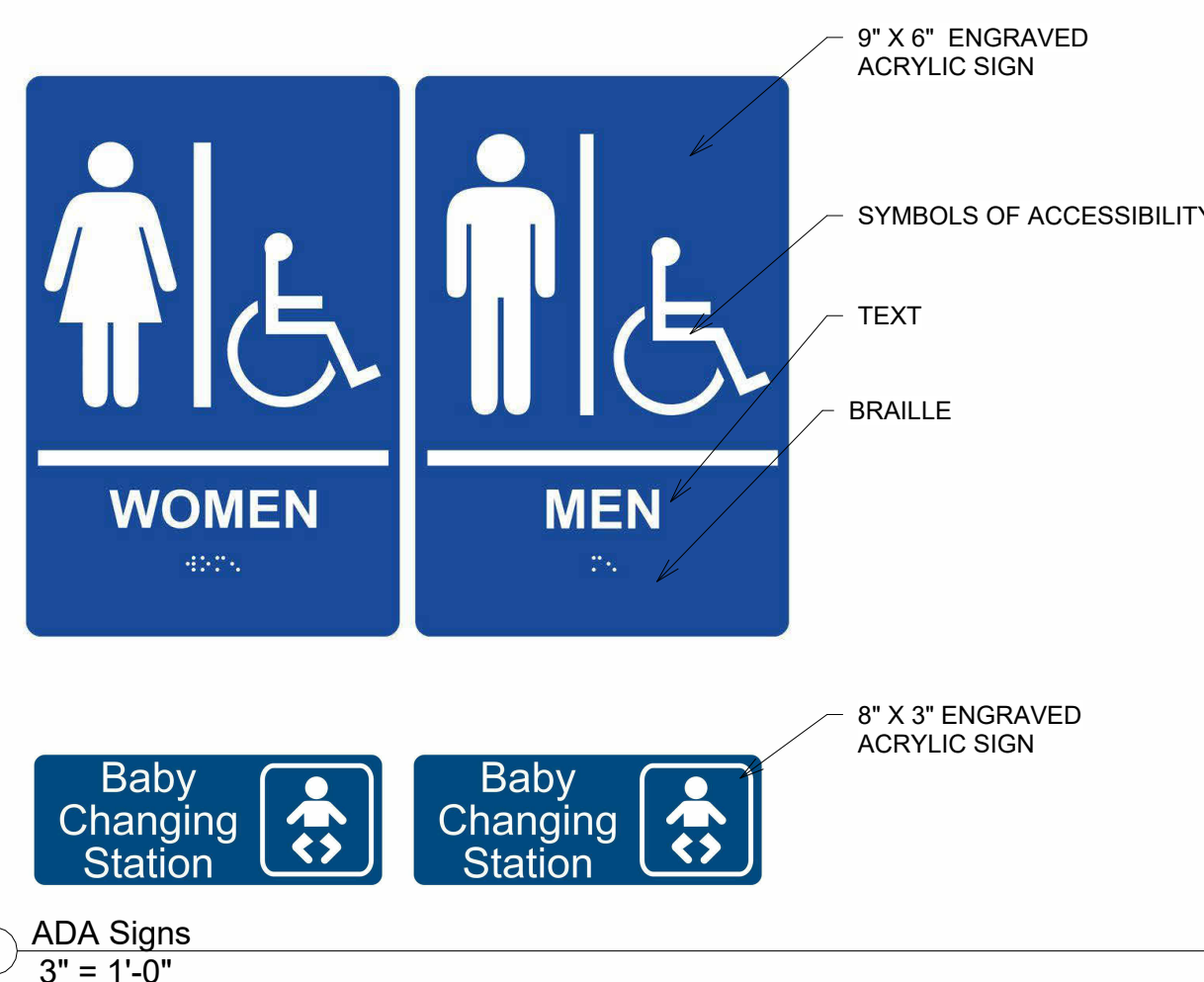
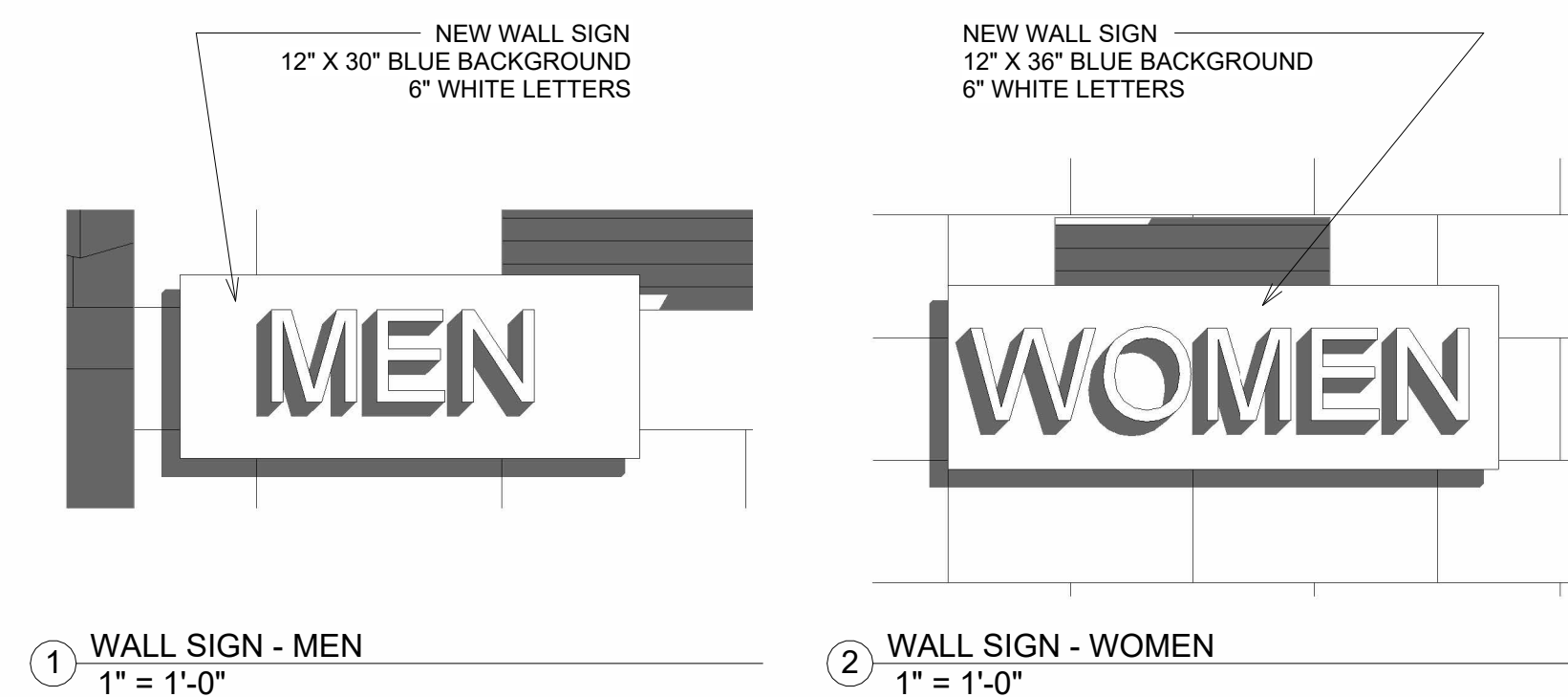
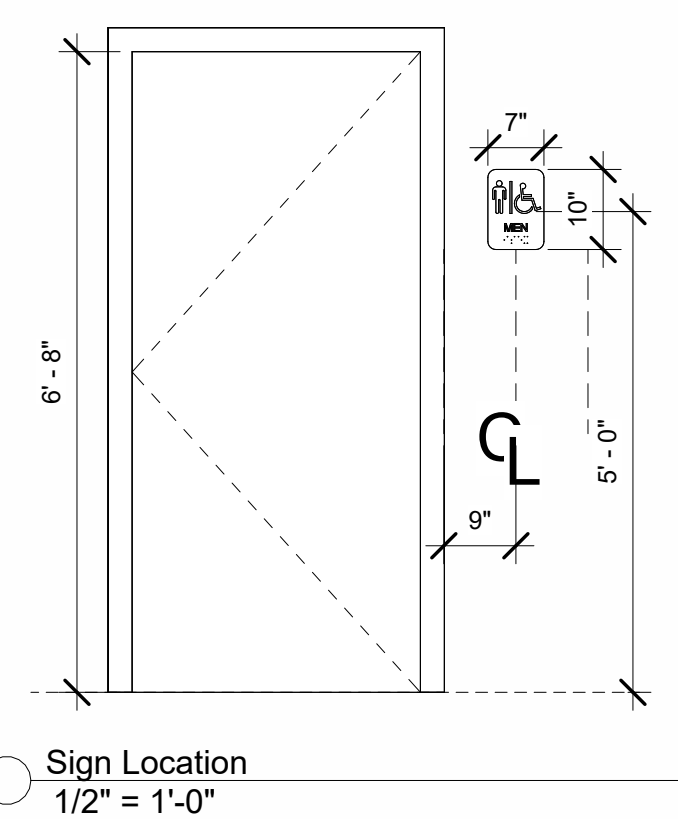

SECTION 10800 - TOILET AND BATH ACCESSORIES

2.1 ACCEPTABLE MANUFACTURERS

A. Manufacturers: Subject to compliance with requirements, provide toilet accessories by one of the following:

1. American Specialties, Inc. (ASI)
2. Bobrick Washroom Equipment, Inc. (Bobrick), or equal.

2.2 MATERIALS, GENERAL

- A. Stainless Steel: AISI Type 302/304, with polished No. 4 finish, 0.034-inch (22-gage) minimum thickness.
- B. Brass: Leaded and unleaded, flat products, ASTM B 19; rods, shapes, forgings, and flat products with finished edges, ASTM B 16; Castings, ASTM B 30.
- C. Sheet Steel: Cold-rolled, commercial quality ASTM A 366, 0.04-inch (20-gage) minimum. Surface preparation and metal pretreatment as required for applied finish.
- D. Galvanized Steel Sheet: ASTM A 527, G60.
- E. Chromium Plating: Nickel and chromium electro-deposited on base metal, ASTM B 456, Type SC 2.
- F. Galvanized Steel Mounting Devices: ASTM A 153, hot-dip galvanized after fabrication.
- G. Fasteners: Screws, bolts, and other devices of same material as accessory unit, or of galvanized steel where concealed.

2.3 ELECTRIC HAND DRYER - see MEP specifications

2.4 TOILET TISSUE DISPENSERS (T.P.D.)

A. Stainless Steel Twin Jumbo Roll Toilet Tissue Dispenser:

1. Mounting: Surface mounted, concealed anchorage.
2. Cabinet: 18-8 S. type 304, 20 gauge stainless steel with satin finish. Equipped with a tumbler lock keyed like other toilet accessories.
3. Capacity: Spindles accommodate two toilet tissue rolls up to 10" diameter with 3" diameter core, or remove outer spindle from the inner spindles to accommodate 2 1/4" diameter core rolls.
4. Subject to conformance with requirements, provide "Model B-2892, Bobrick.

2.6.5 GRAB BARS (G.B.)

A. Stainless Steel Type: Provide grab bars with wall thickness not less than 0.05 inch (18 gage) and as follows:

1. Mounting: Concealed, manufacturer's standard flanges and anchorages.
2. Clearance: 1-1/2-inch clearance between wall surface and inside face of bar.
3. Gripping Surfaces: Manufacturer's standard nonslip texture.
4. Heavy-Duty Size: Outside diameter of 1-1/2 inches.
5. Subject to conformance with requirements, provide grab bar units manufactured by Bobrick Washroom Equipment, Inc.:

- a. "Model B-6806x36", for rear wall installation
- a. "Model B-6806x42", for side wall installation
- b. "Model B-6806x18", for side wall installation
- c. "Model B-4998", for swing-up grab bar
- d. "Model B-68616", for boot wash at Stair 3
- e. "Model B-6806x48", for boot wash at Stair 3

2.6 ROBE HOOKS (R.H.)

A. Single-Prong Single Robe Hook: Heavy-duty satin finished stainless steel single-prong robe hook; rectangular wall bracket with backplate for concealed mounting.

1. Subject to conformance with requirements, provide "Model B-2116", Bobrick.

2.7 SOAP DISPENSERS (S.D.)

A. Wall Mounted:

1. Surface mounted soap dispenser for liquid and lotion soaps and detergents.
2. Capacity: 40 fluid ounces.
3. Construction: 18-8 S, type 304, 22 gauge stainless steel with satin finish. Body is drawn, one-piece seamless construction. Back plate has mounting bracket attached. Furnished with concealed wall plate.
4. Subject to conformance with requirements, provide "Model B-2111", Bobrick.

2.8 MIRRORS (M.W.F.)

A. Wall Mounted Mirrors with Frames:

1. Subject to conformance with requirements, provide "Model B-166-1830", BOBRICK.
2. Quantity: Provide one (1) unit for Male Bathroom, one (1) unit for Female Bathroom.

2.9 BABY CHANGING STATION (B.C.S.)

A. Wall Mounted:

1. Subject to conformance with requirements, provide "Model KB200-01", KOALA KARE.
2. Quantity: Provide one (1) unit for Male Bathroom, one (1) unit for Female Bathroom.

RENOVATION TO EXISTING BATHROOM AT QUINNIPIAC PARK
 QUINNIPIAC PARK, 1325 CHESHIRE STREET, CHESHIRE, CT

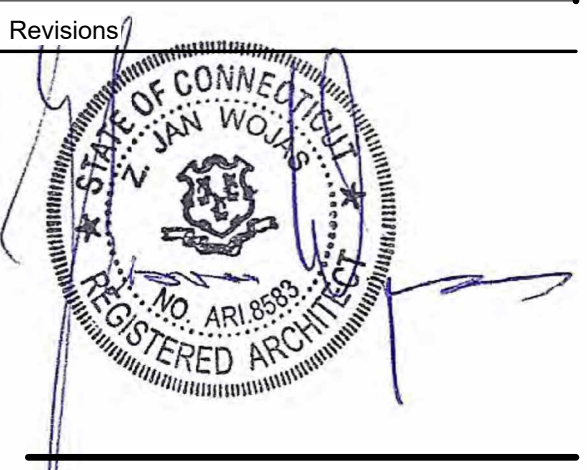

WOJAS.ARCH, LLC

5 Race Track Hollow
 Middlefield, CT 06455
 Phone: 860-930-5322
 www.wojas.us
 email: jan@wojas.us

HANDICAP SIGNS AND ACCESSORIES

PROJ. NO. 2122-10	DRAWING NO. A2
SCALE: As indicated	
DATE: 3/7/2022	

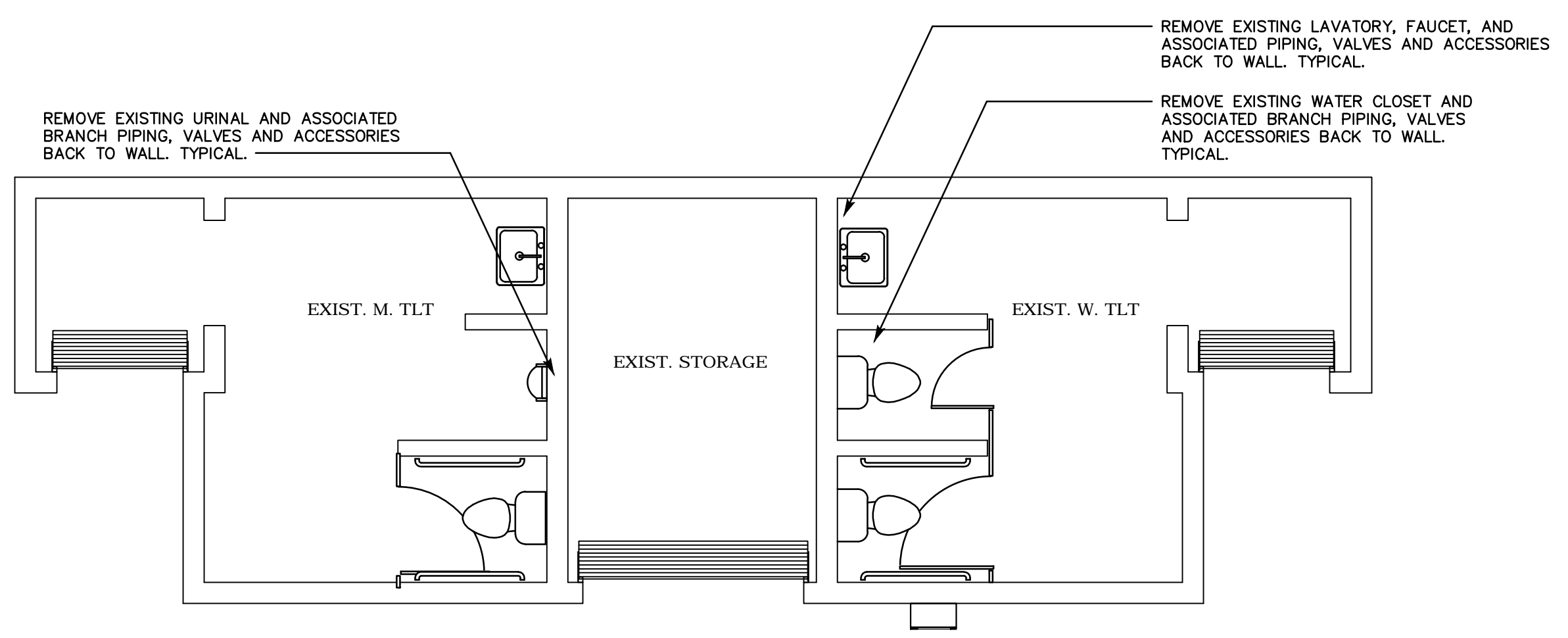

PLUMBING PLAN – DEMOLITION
 SCALE: 1/4"=1'-0"

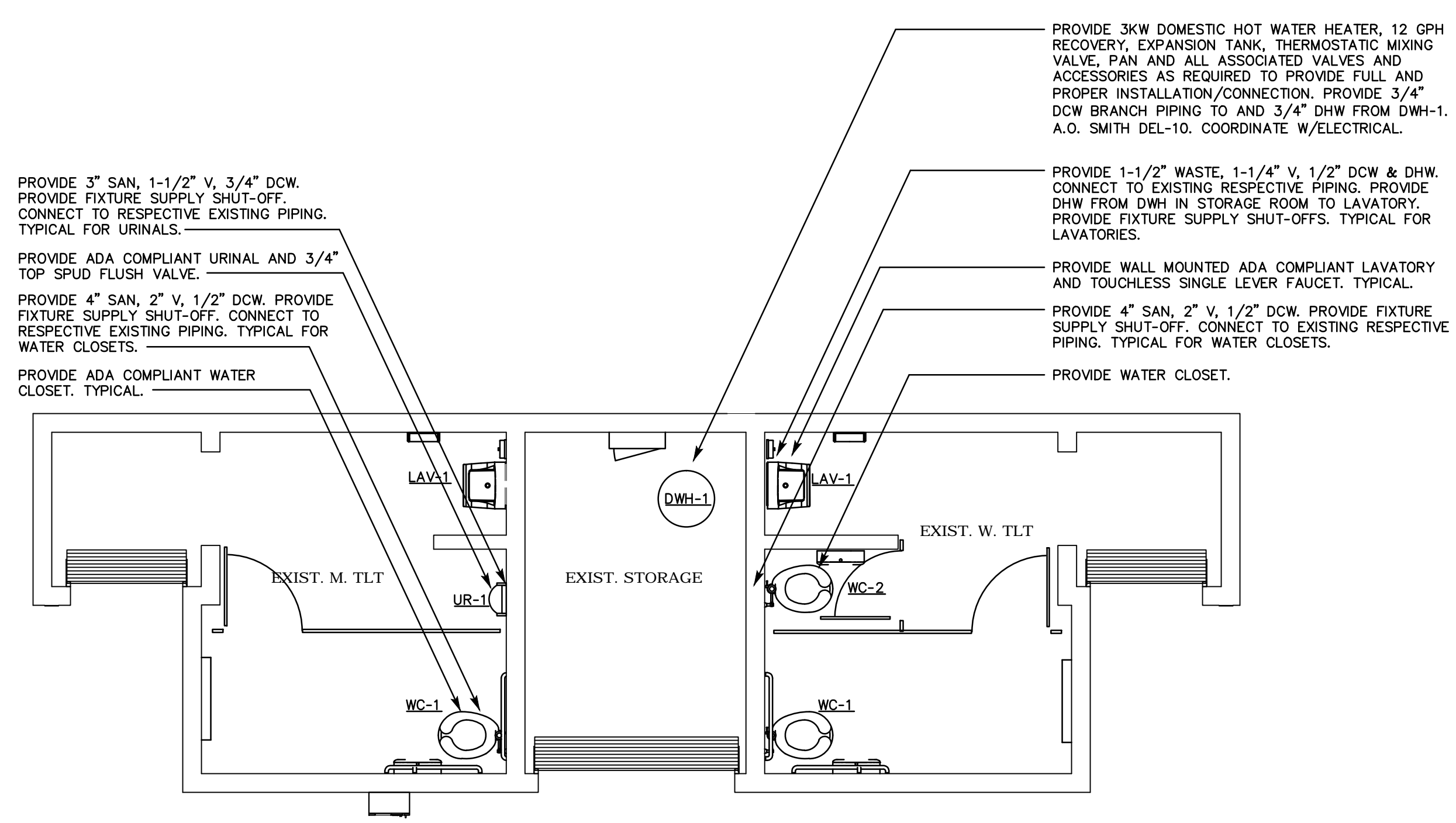

PLUMBING PLAN – PROPOSED
 SCALE: 1/4"=1'-0"

NOTE:
 PITCH DOMESTIC WATER PIPING. PROVIDE LOW POINT DRAINS AS REQUIRED FOR WINTERIZATION. TYPICAL.

EXISTING CONDITIONS NOTE:
 THE CONTRACTOR(S) SHALL VISIT THE SITE PRIOR TO BIDDING, NOTING EXISTING CONDITIONS AND EQUIPMENT. IF SAID EQUIPMENT IS NOT BEING REMOVED AS PART OF THE PROJECT OR IS NOTED AS EXISTING TO REMAIN AND IMPEDES PROVIDING PROPOSED EQUIPMENT AND/OR PROVIDING PROPOSED SCOPE OF WORK, EQUIPMENT SHALL BE TEMPORARILY RELOCATED AND COMPLETELY REINSTALLED AFTER PROPOSED SCOPE OF WORK IS COMPLETED. THIS SHALL BE PART OF THE BASE BID AND CONTRACTOR(S) SHALL BID ACCORDINGLY. NO ADDITIONAL COMPENSATION WILL BE CONSIDERED FOR RELATED WORK OR COORDINATION WITH EXISTING CONDITIONS.

- GENERAL NOTES:**
- CONTRACTOR SHALL VISIT THE SITE PRIOR TO BIDDING AND BECOME INFORMED AS TO THE EXISTING CONDITIONS AND THE NATURE AND SCOPE OF WORK REQUIRED.
 - THE CONTRACTOR SHALL BE RESPONSIBLE FOR ALL WORK INCLUDING TOOLS, MATERIAL, MANPOWER, ETC. REQUIRED FOR COMPLETE AND PROPER INSTALLATION OF PROPOSED MATERIALS, FIXTURES AND/OR EQUIPMENT.
 - ALL WORK REQUIRED SHALL BE PERFORMED BY QUALIFIED, LICENSED PERSONNEL AS REQUIRED BY ALL APPLICABLE CODES AND STANDARDS.
 - DRAWINGS ARE DIAGRAMMATIC. CONTRACTOR SHALL FIELD VERIFY ALL LOCATIONS AND DIMENSIONS OF EXISTING MATERIALS, FIXTURES AND/OR EQUIPMENT WITHIN AND AFFECTING PROJECT SCOPE OF WORK.
 - ALL WORK TO BE DONE IN ACCORDANCE WITH STATE AND LOCAL CODE.
 - ALL SERVICE DISRUPTIONS MUST BE SCHEDULED A MINIMUM OF 72 HOURS IN ADVANCE WITH THE OWNER'S REPRESENTATIVE.
 - ALL WORK SHALL BE COORDINATED AMONG ALL PROJECT DISCIPLINES, EXISTING CONDITIONS, ALL APPLICABLE STATE AND LOCAL CODES AND ORDINANCES, AND AUTHORITIES HAVING JURISDICTION.
 - CONTRACTOR IS TO FIELD VERIFY ALL DIMENSIONS BEFORE ORDERING ANY FIXTURE OR MATERIALS.
 - INTEGRITY OF ALL FIRE-RATED WALLS BETWEEN SECTIONS OF THE BUILDING SHALL BE MAINTAINED. TYPICAL.
 - CONTRACTOR SHALL BE RESPONSIBLE TO FOLLOW ALL STATE AND LOCAL CODES AND STANDARDS. ALL EQUIPMENT/FIXTURES, AS NOTED, SHALL BE PROVIDED MEETING ANSI A117.1-2003 CODES AND STANDARDS WHERE APPLICABLE. ANY OUT OF COMPLIANCE FINES DUE TO IMPROPER INSTALLATION OR NON-COMPLIANT EQUIPMENT/FIXTURES SHALL BE THE RESPONSIBILITY OF THE CONTRACTOR.

- PLUMBING NOTES:**
- CONTRACTOR SHALL PROVIDE ALL PIPING, FITTINGS AND ACCESSORIES REQUIRED FOR PROPER INSTALLATION OF, CONNECTION TO, AND OPERATION OF PROPOSED FIXTURES AND EQUIPMENT. COORDINATE WORK WITH ALL OTHER PROJECT DISCIPLINES, AND ALL APPLICABLE CODES AND STANDARDS. COORDINATE ALL PIPE SIZES AND ROUTING WITH EXISTING CONDITIONS. TYPICAL.
 - ALL MATERIALS SHALL COMPLY WITH ALL APPLICABLE FEDERAL, STATE AND LOCAL CODES AND/OR REFERENCED STANDARDS REQUIRED BY CODES. PROVIDE MATERIALS ACCORDINGLY. TYPICAL.
 - ALL FLOOR DRAINS SHALL BE PROVIDED WITH TRAPS WITH TRAP PRIMER CONNECTIONS. INSTALL TRAP PRIMER AND ASSOCIATED PIPING PER MANUFACTURER'S INSTRUCTIONS AND CODE. TYPICAL.
 - ALL ABOVE GRADE DOMESTIC WATER PIPING SHALL BE ASTM B88 TYPE L COPPER. TYPICAL.
 - PROVIDE SHUT OFF VALVES, FULL SIZE OF PIPE, AT ALL DOMESTIC WATER BRANCHES TO PROPOSED FIXTURES. TYPICAL.
 - PROVIDE CLEANOUTS FOR PROPOSED SANITARY PIPING AS REQUIRED PER CURRENT APPLICABLE CODES AND STANDARDS. TYPICAL.
 - PROVIDE PLUMBING FIXTURES OF TYPE INDICATED. PROVIDE ALL PIPING, VALVES AND ACCESSORIES AS REQUIRED FOR FULL AND PROPER INSTALLATION PER CURRENT CODE AND MANUFACTURER'S INSTALLATION INSTRUCTIONS AND RECOMMENDATIONS. TYPICAL.
 - EXISTING CLEANOUTS LOCATED ABOVE FINISHED FLOOR SHALL BE REMOVED AND REPLACED WITH FLOOR CLEANOUT AND COVER MOUNTED FLUSH WITH FINISHED FLOOR. TYPICAL.

Revisions

Revisions

PLUMBING GENERAL NOTES

- NOTES BELOW ARE NOT INTENDED TO REPLACE SPECIFICATIONS. SEE SPECIFICATIONS FOR REQUIREMENTS IN ADDITION TO GENERAL NOTES.
- PROVIDE FIXTURE SHUT-OFF VALVES AND P-TRAPS FOR ALL FIXTURES PROVIDED. PROVIDE SANITARY, WASTE AND DOMESTIC WATER PIPING AS REQUIRED FOR ALL FIXTURES PROVIDED.
- REFER TO AND CAREFULLY CHECK ARCHITECTURAL, ELECTRICAL AND MECHANICAL DRAWINGS AND DETAILS, NOTING LOCATIONS WHERE WALLS, PARTITIONS, CEILINGS AND OTHER SURFACES ARE FURRED, LOCATION OF PIPE SLEEVES, LOCATIONS OF PIPE SHAFTS AND CONFLICTS WITH WORK OF OTHER TRADES AND ARRANGE WORK ACCORDINGLY. FURNISH ALL OFFSETS, FITTINGS, VALVES, DRAINS, ETC. REQUIRED TO MEET SUCH CONDITIONS.
- DUE TO SCALE OF DRAWINGS, ALL REQUIRED OFFSETS, FITTINGS, VALVES, DRAINS, ETC. MAY NOT BE INDICATED.
- ALL PIPING PASSING THROUGH FIRE RATED WALLS SHALL BE PROVIDED WITH SCHEDULE 40 STEEL PIPE SLEEVES AND SPACE BETWEEN EXTERIOR OF PIPE AND INTERIOR OF PIPE SLEEVE PACKED WITH A FIRE RATED MATERIAL EQUAL TO THE RATING OF THE WALL.
- UNLESS OTHERWISE INDICATED, PROVIDE A COMPLETE AND OPERATIONAL MECHANICAL SYSTEM INCLUDING ALL NECESSARY MATERIAL, LABOR AND EQUIPMENT.
- CONTRACTOR SHALL OBTAIN AND PAY FOR ALL REQUIRED PERMITS AND ARRANGE FOR ALL REQUIRED INSPECTIONS IN ACCORDANCE WITH STATE AND LOCAL GOVERNING CODES.
- THE TERM "PROVIDE" SHALL MEAN "TO FURNISH, INSTALL AND CONNECT COMPLETELY."
- WHERE THE CONTRACTOR PROPOSES TO USE AN ITEM OF EQUIPMENT OTHER THAN THAT SPECIFIED OR DETAILED ON THE DRAWINGS WHICH REQUIRES ANY REDESIGN OF THE STRUCTURE, PARTITIONS, FOUNDATIONS, PIPING, WIRING OR ANY OTHER PART OF THE MECHANICAL, ELECTRICAL OR ARCHITECTURAL LAYOUT, ALL SUCH REDESIGN AND ALL NEW DRAWINGS AND DETAILING REQUIRED THEREFORE, SHALL BE PREPARED AT THE CONTRACTOR'S EXPENSE AND ARE SUBJECT TO THE REVIEW AND APPROVAL OF THE OWNER OR HIS AUTHORIZED REPRESENTATIVE. OWNER RESERVES THE RIGHT TO HAVE THE ARCHITECT OR ENGINEER OF HIS CHOICE PREPARE ANY REDESIGN WORK.
- ALL WORK SHALL BE DONE WITH LICENSED WORKMEN IN ACCORDANCE WITH STATE AND LOCAL GOVERNING AUTHORITIES.
- CONTRACTOR SHALL MAKE ADEQUATE PROVISIONS FOR PIPE SLOPE AND ANCHORAGE.
- BEFORE CUTTING OR DRILLING INTO BUILDING ELEMENTS, INSPECT AND LAYOUT WORK TO AVOID DAMAGING STRUCTURAL ELEMENTS AND BUILDING UTILITIES.
- ALL WORK SHALL BE DONE IN ACCORDANCE WITH THE LATEST ACCEPTED:
 - INTERNATIONAL BUILDING CODE
 - CONNECTICUT BUILDING CODE AND SUPPLEMENT
 - INTERNATIONAL MECHANICAL CODE
 - ASTM & ANSI STANDARDS.
 - INTERNATIONAL PLUMBING CODE
 - FIRE SAFETY CODE
- CONTRACTOR SHALL BE RESPONSIBLE FOR REPAIR AND PAYMENT FOR ALL UTILITIES DAMAGED DURING CONSTRUCTION.
- CONTRACTOR TO CONFIRM PIPE LOCATIONS, ELEVATIONS, AND SIZES BEFORE ANY WORK IS STARTED. IF ANY DISCREPANCIES ARE FOUND NOTIFY ENGINEER BEFORE PROCEEDING WITH WORK.
- PROVIDE WATER SERVICE SHUT OFF VALVES ON WATER SUPPLY IMMEDIATELY ADJACENT TO PLUMBING FIXTURES.
- PROVIDE SEISMIC BRACING OF ALL PLUMBING PIPES PER THE CONNECTICUT BUILDING CODE.
- PROVIDE WATER HAMMER ARRESTERS FOR ALL FLUSH VALVES. SIZE AND LOCATE IN ACCORDANCE WITH MANUFACTURER'S RECOMMENDATIONS.
- FOLLOW MANUFACTURER'S INSTRUCTIONS AND RECOMMENDATIONS FOR INSTALLATION OF PROVIDED EQUIPMENT.
- ALL PIPES THAT PENETRATE WALLS, FLOORS AND CEILINGS IN FINISHED AREAS SHALL RECEIVE CHROME PLATED METAL ESCUTCHEONS.
- ALL SHOP DRAWINGS OF INDIVIDUAL COMPONENTS ARE TO BE SUBMITTED AS A COMPLETE PACKAGE.
- ALL SHOP DRAWINGS OF RELATED COMPONENTS SHALL BE SUBMITTED AS A COMPLETE PACKAGE.
- ALL WORK IN INTERIOR FINISHED SPACES IS TO BE CONCEALED BEHIND WALLS, ABOVE CEILINGS, OR UNDER THE FLOOR. PROVIDE ALL NECESSARY CUTTING, PATCHING, REPAINTING AND/OR REPLACEMENT OF FINISHES AS REQUIRED TO PERFORM WORK.
- WRITTEN REQUESTS FOR PLANNED SHUTDOWN OR INTERRUPTION OF BUILDING SERVICES, SYSTEMS OR EQUIPMENT SHALL BE MADE IN WRITING 72 HOURS PRIOR TO START OF THE REQUESTED SHUTDOWN PERIOD.
- SUPPORT PIPING ABOVE SUSPENDED CEILING, FROM CONSTRUCTION ABOVE, AS CLOSE AS POSSIBLE TO BOTTOM OF SLABS, BEAMS, MAINTAINING MAXIMUM HEADROOM AT ALL TIMES.
- PROVIDE CLEANOUTS PER PLUMBING CODE.
- ISLE AND CORRIDOR WAYS THROUGH CONSTRUCTION AREAS WHICH ARE REQUIRED FOR EGRESS (NORMAL OR EMERGENCY) SHALL BE KEPT CLEAR OF MATERIAL, EQUIPMENT, & DEBRIS.
- ALL WORK SHALL BE LICENSED WORKMAN IN ACCORDANCE WITH STATE AND LOCAL GOVERNING AUTHORITIES.
- INSULATE PLUMBING PIPING AS REQUIRED PER IBC AND LOCAL CODE REQUIREMENTS. TYPICAL.

PLUMBING SYMBOL LIST

	BALL VALVE
	GATE VALVE
	CAP
	PIPE ELBOW, TURNED UP
	PIPE ELBOW, TURNED DOWN
	DOMESTIC COLD WATER SUPPLY PIPING
	DOMESTIC HOT WATER SUPPLY PIPING
	SANITARY VENT PIPING
	PIPING TO BE PROVIDED
	UNDER SLAB PIPING TO BE PROVIDED
	CLEAN OUT
	FLOOR DRAIN
	TRAP PRIMER
	NON-FREEZE WALL HYDRANT

PLUMBING ABBREVIATIONS

C.O.	CLEANOUT
DCW	DOMESTIC COLD WATER SUPPLY
DHW	DOMESTIC HOT WATER SUPPLY
DN	DOWN
DWH	DOMESTIC WATER HEATER
ET	EXPANSION TANK
FD	FLOOR DRAIN
GPH	GALLONS PER HOUR
GPM	GALLONS PER MINUTE
LAV	LAVATORY
NFWH	NON-FREEZE WALL HYDRANT
NTS	NOT TO SCALE
SAN	SANITARY
TM	THERMOSTATIC MIXING VALVE
TYP	TYPICAL
UR	URINAL
VTR	SANITARY VENT THROUGH ROOF
WC	WATER CLOSET

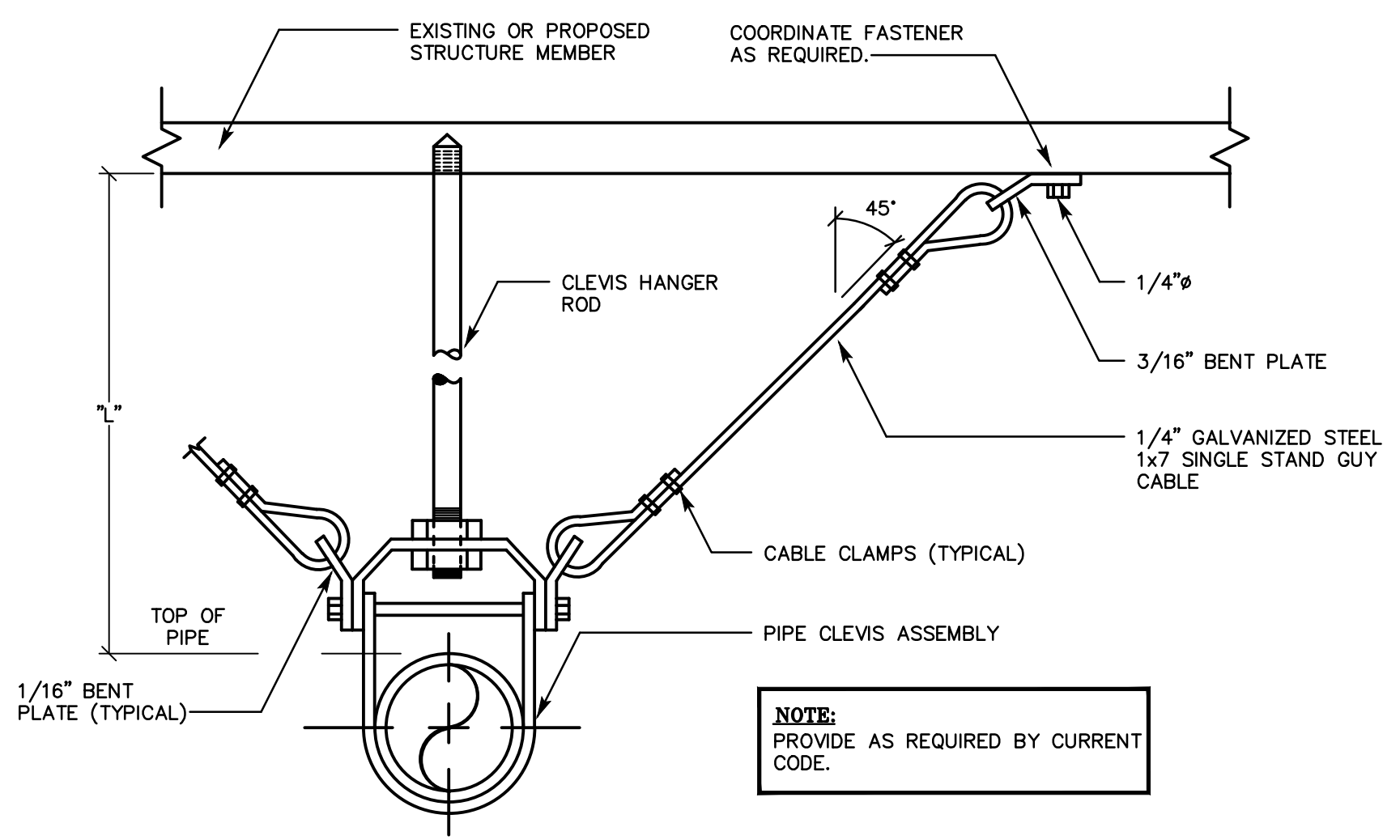

TYPICAL SEISMIC RESTRAINT ASSEMBLY OF SUSPENDED PIPING
 SCALE: N.T.S.

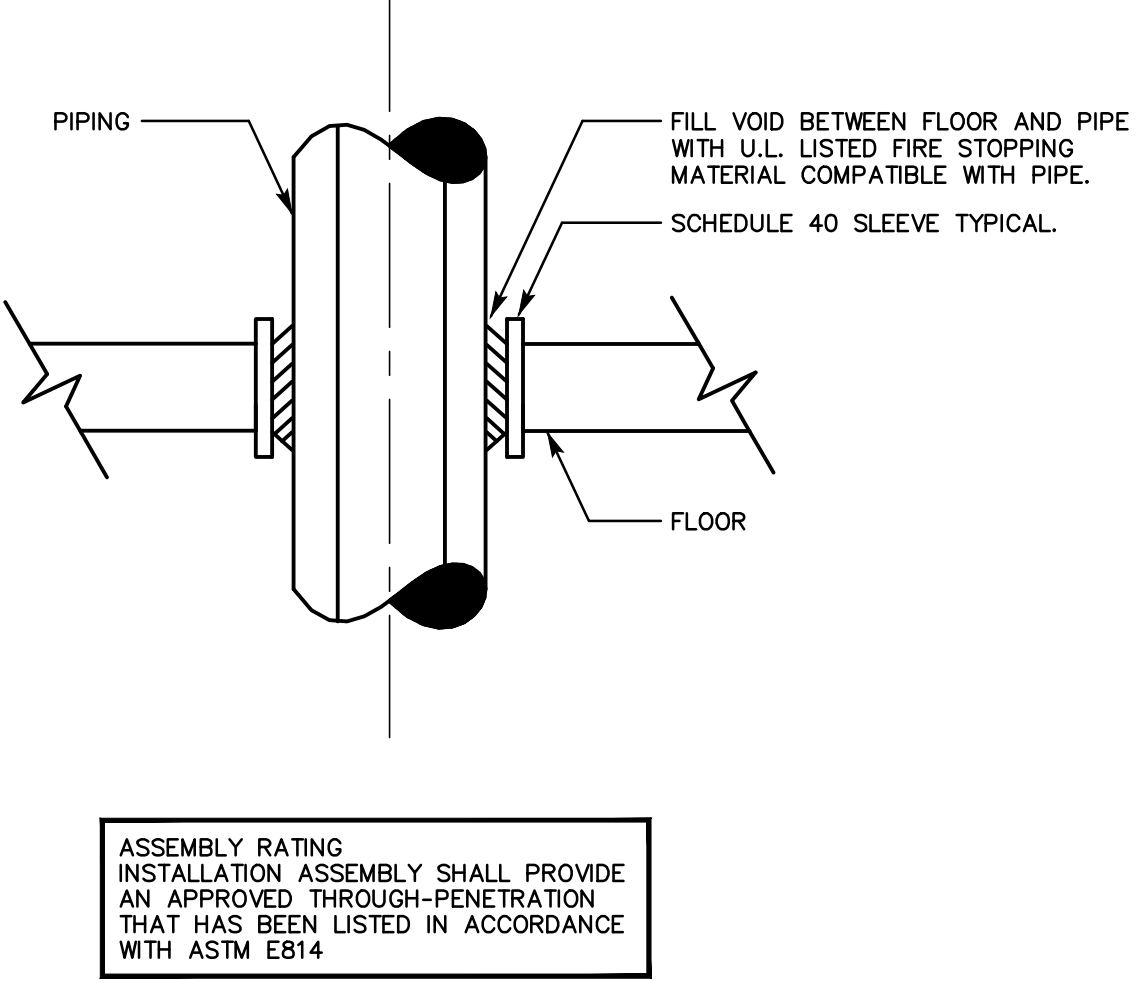

TYPICAL FLOOR PIPE PENETRATION FIRE STOPPING DETAIL
 SCALE: N.T.S.

PLUMBING FIXTURE SCHEDULE			
DESIGNATION	DESCRIPTION	FIXTURE	FITTINGS
LAV-1	LAVATORY WALL MOUNT ANSI A117.1 COMPLIANT	VITREOUS CHINA, 20-1/2"x18-1/4" SELF-RIMMING FRONT OVERFLOW, BACK AND SIDE SPLASH SHIELDS AMERICAN STANDARD LUCERNE MOUNT AS REQUIRED FOR ADA/ANSI COMPLIANCE	ELECTRONIC TOUCHLESS FAUCET & XFMR BRASS AND COPPER WATERWAY, ADJUSTABLE HOT LIMIT SAFETY STOP, SLOAN ETF-600
UR-1	URINAL WALL MOUNT ANSI A117.1 COMPLIANT	VITREOUS CHINA, SIPHON JET, 3/4" TOP SPUD, 1.0 GPF AMERICAN STANDARD ALLBROOK MOUNT AS REQUIRED FOR ADA/ANSI COMPLIANCE	PROVIDE WITH SENSOR OPERATED FLUSH VALVE SLOAN ROYAL 180 ESS
WC-1	WATER CLOSET FLOOR MOUNTED REAR DISCHARGE ANSI A117.1-2003 COMPLIANT	LOW CONSUMPTION, VITREOUS CHINA, ELONGATED, COMFORT HEIGHT 16-1/2", 1.6 GPF CLOSE-COUPLED TANK AMERICAN STANDARD YORKVILLE 2878.016	SOLID PLASTIC ELONGATED SEAT OPEN FRONT, NO COVER
WC-2	WATER CLOSET FLOOR MOUNTED	LOW CONSUMPTION, VITREOUS CHINA, ROUND FRONT COMFORT HEIGHT 16-1/2", 1.28 GPF CLOSE-COUPLED TANK AMERICAN STANDARD CADET 270BA.101	SOLID PLASTIC SEAT OPEN FRONT, NO COVER

- NOTES:**
- INSULATE SUPPLIES AND WASTE FOR ALL ANSI A117.1-2003 COMPLIANT FIXTURES WITH HANDI-LAV GUARD BY TRUEBRO, TYPICAL.
 - SEE PLUMBING FLOOR PLANS FOR FURTHER REQUIREMENTS. TYPICAL.
 - PROVIDE HEAVY DUTY ADJUSTABLE FIXTURE CARRIERS. TYPICAL.
 - TRIP LEVERS/FLUSH CONTROLS SHALL BE LOCATED ON THE OPEN SIDE OF ANSI A117.1-2003 COMPLIANT WATER CLOSETS. TYPICAL.
 - PROVIDE TRANSFORMERS FOR ALL TOUCHLESS FIXTURES. COORDINATE QUANTITY OF FIXTURES PER TRANSFORMER WITH ELECTRICAL AND MANUFACTURER'S REQUIREMENTS. COORDINATE REQUIREMENTS AND INSTALLATION W/DIV. 16. TYPICAL.

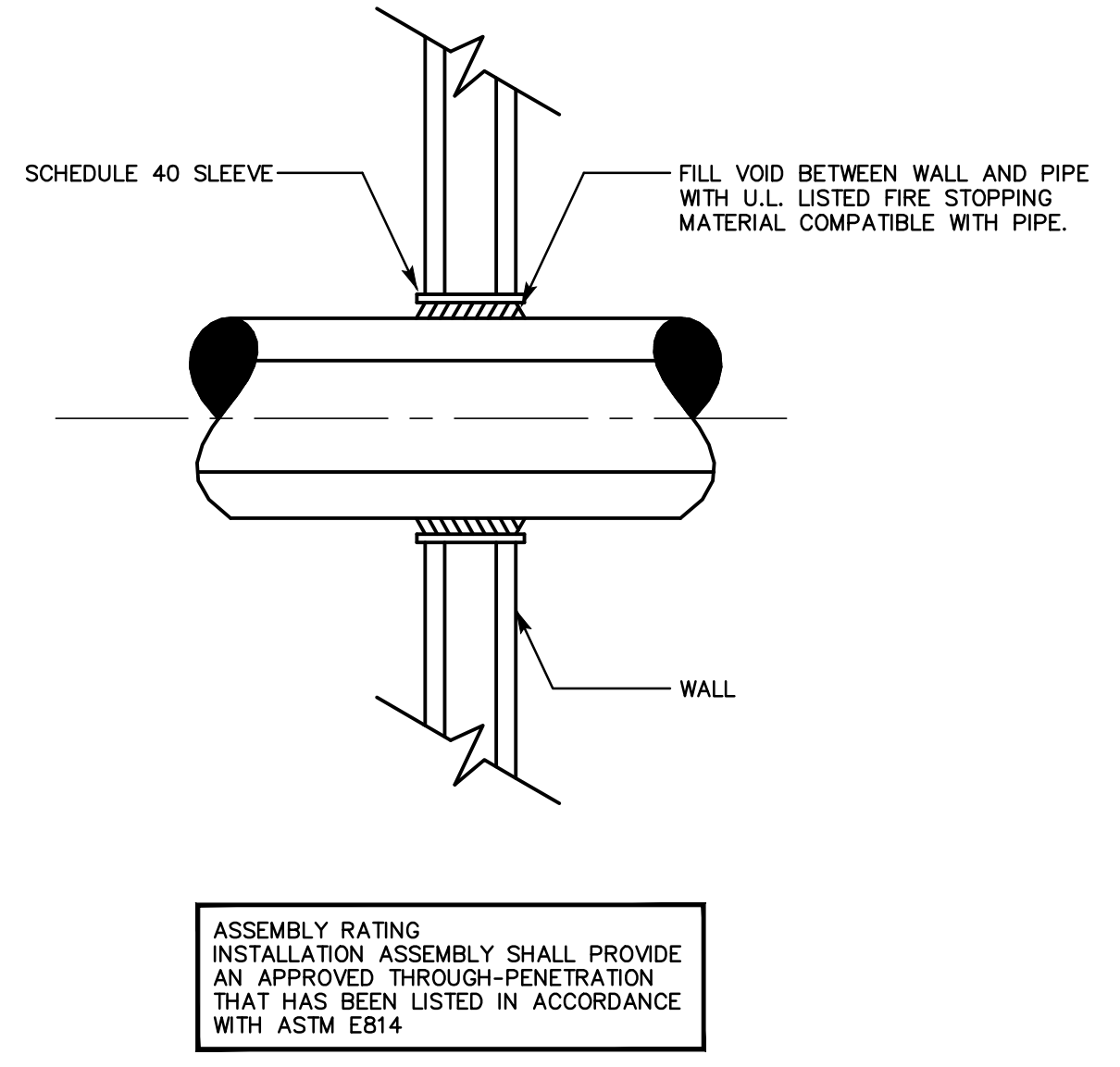

TYPICAL WALL PIPE PENETRATION FIRE STOPPING DETAIL
 SCALE: N.T.S.

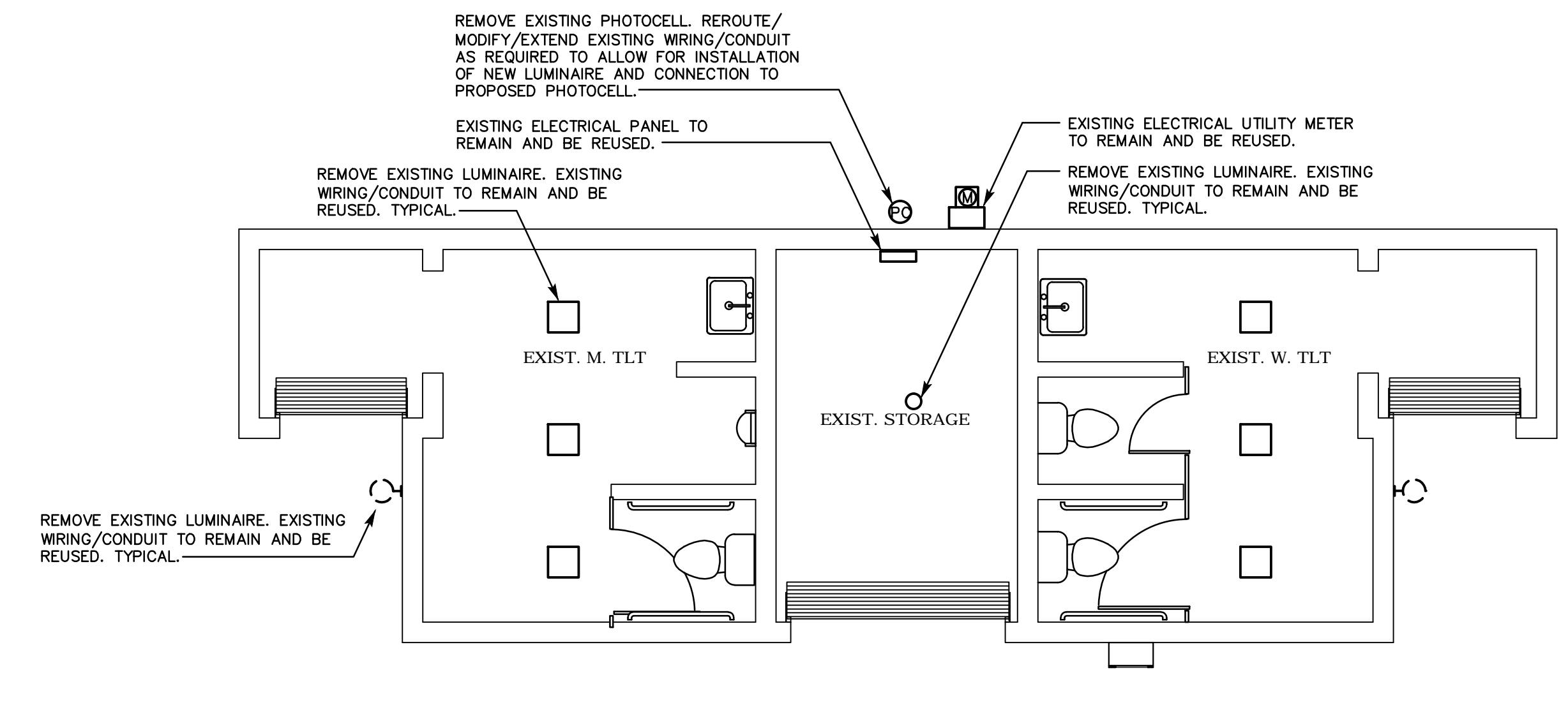

MECHANICAL/ELECTRICAL PLAN - DEMOLITION
 SCALE: 1/4"=1'-0"

- ELECTRICAL DEMOLITION NOTES:**
1. THE CONTRACTOR SHALL VISIT THE PROJECT SITE AND BECOME INFORMED AS TO THE NATURE AND SCOPE OF DEMOLITION WORK REQUIRED, NOTING AND ACCOUNTING FOR EXISTING CONDITIONS. TYPICAL.
 2. REMOVE AND PROPERLY DISPOSE OF EQUIPMENT AND ASSOCIATED COMPONENTS/ACCESSORIES AS INDICATED ON DEMOLITION PLANS. PROPERLY DISPOSE OF ALL DEMOLITION DEBRIS AS REQUIRED BY FEDERAL, STATE AND LOCAL CODES AND ORDINANCES. TYPICAL.
 3. CONTRACTOR SHALL NOT DAMAGE ANY EXISTING EQUIPMENT, PIPING, OR ASSOCIATED ACCESSORIES WHICH ARE TO REMAIN. ANY SUCH ITEMS DAMAGED SHALL BE REPLACED AT CONTRACTOR'S EXPENSE. TYPICAL.
 4. CONTRACTOR SHALL NOT DAMAGE ANY EXISTING ELECTRICAL CONNECTIONS, WIRING AND ASSOCIATED ACCESSORIES WHICH ARE TO REMAIN. ANY SUCH ITEMS DAMAGED SHALL BE REPLACED AT CONTRACTOR'S EXPENSE. TYPICAL.
 5. ALL DEMOLITION WORK SHALL BE PERFORMED IN A SAFE AND ORDERLY MANNER WITH QUALIFIED AND LICENSED PERSONNEL IN ACCORDANCE WITH STATE AND LOCAL GOVERNING AUTHORITIES AND ALL APPLICABLE CODES AND STANDARDS. COORDINATE WORK WITH ALL PROJECT DISCIPLINES AND EXISTING CONDITIONS. TYPICAL.
 6. CONTRACTOR SHALL PROVIDE MINIMUM OF 72 HOURS NOTICE PRIOR TO ANY EQUIPMENT/SERVICE SHUT DOWN.
 7. DRAWINGS ARE DIAGRAMMATIC. CONTRACTOR SHALL FIELD VERIFY ALL EXISTING CONDITIONS INCLUDED IN AND RELATED TO THE PROJECT SCOPE OF WORK. TYPICAL.

NOTE:
 DO NOT DISTURB ANY SUSPECTED HAZARDOUS MATERIALS. NOTIFY OWNER'S REPRESENTATIVE OF ANY SUSPECTED MATERIALS IMPEDING PERFORMANCE OF WORK. TYPICAL.

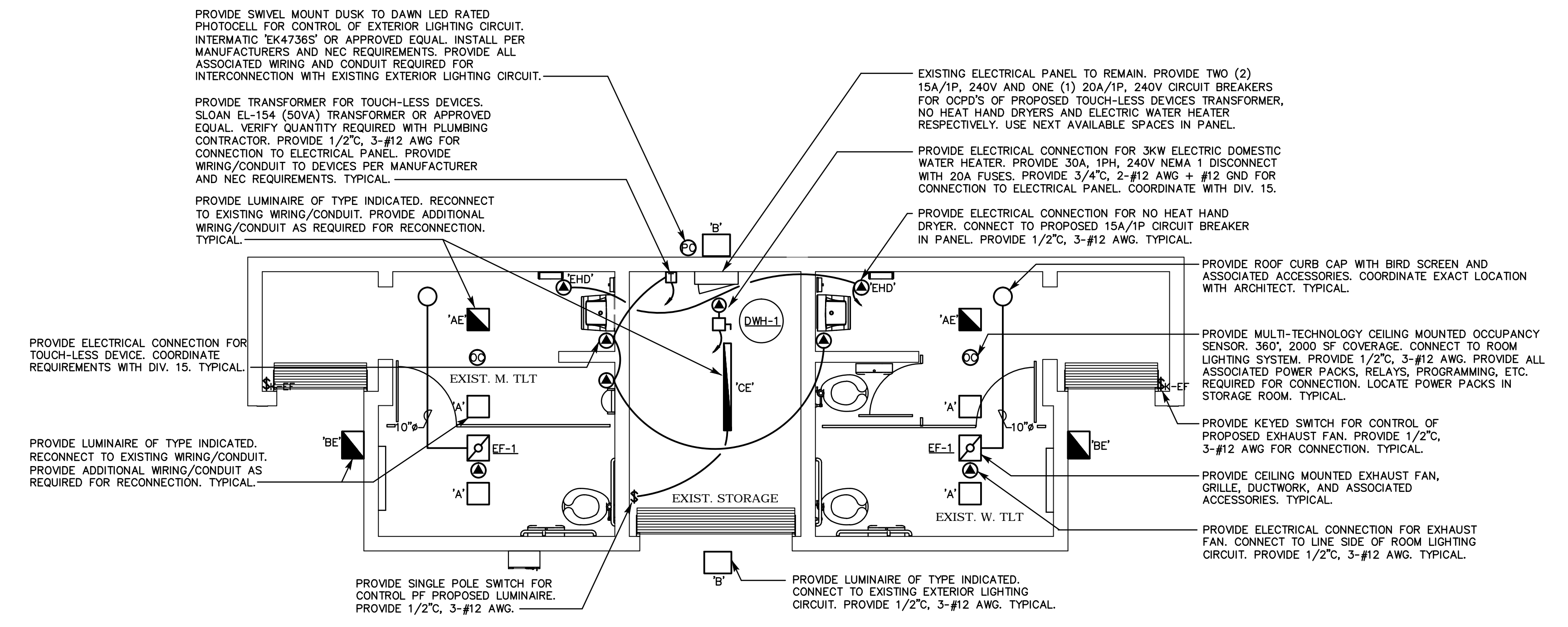

MECHANICAL/ELECTRICAL PLAN - PROPOSED
 SCALE: 1/4"=1'-0"

- GENERAL NOTES:**
1. THE CONTRACTOR SHALL BE RESPONSIBLE FOR ALL WORK INCLUDING TOOLS, MATERIAL, MANPOWER, ETC. REQUIRED FOR COMPLETE AND PROPER INSTALLATION OF PROPOSED MATERIALS, FIXTURES AND/OR EQUIPMENT.
 2. DRAWINGS ARE DIAGRAMMATIC. CONTRACTOR SHALL VERIFY ALL LOCATIONS, QUANTITIES AND DIMENSIONS OF PROPOSED MATERIALS, FIXTURES AND/OR EQUIPMENT WITHIN AND AFFECTING PROJECT SCOPE OF WORK.
 3. ALL WORK SHALL BE PERFORMED IN A SAFE AND ORDERLY MANNER WITH QUALIFIED AND LICENSED PERSONNEL IN ACCORDANCE WITH STATE AND LOCAL GOVERNING AUTHORITIES AND ALL APPLICABLE CODES AND STANDARDS. TYPICAL.
 4. ROUTING OF ALL CONDUIT SHALL BE COORDINATED WITH EXISTING CONDITIONS, STRUCTURAL FRAMING ELEMENTS AND ALL OTHER PROJECT DISCIPLINES. TYPICAL.
 5. BUILDING WILL BE OCCUPIED DURING ALL PHASES OF CONSTRUCTION. ALL WORK WILL BE PERFORMED CAUSING MINIMAL DISRUPTION TO THE FACILITY. CONTAIN AND CONTROL CONSTRUCTION DEBRIS SO AS NOT TO INTERFERE WITH DAILY OPERATION OF BUILDING. KEEP EGRESS PATHS FREE AND CLEAR OF ANY OBSTRUCTIONS.
 6. ALL SERVICE DISRUPTIONS MUST BE SCHEDULED A MINIMUM OF 72 HOURS IN ADVANCE WITH THE OWNER'S REPRESENTATIVE.
 7. CONTRACTOR SHALL NOT DAMAGE ANY EXISTING EQUIPMENT, PIPING, OR ASSOCIATED ACCESSORIES WHICH ARE TO REMAIN.
 8. PROVIDE ALL REQUIRED PENETRATIONS. COORDINATE WITH EXISTING STRUCTURAL ELEMENTS. FIRE STOP ALL PENETRATIONS. TYPICAL.
 9. INSTALL ALL EQUIPMENT AND ASSOCIATED ACCESSORIES PER NEC AND MANUFACTURER'S REQUIREMENTS.

EXISTING CONDITIONS NOTE:
 THE CONTRACTOR(S) SHALL VISIT THE SITE PRIOR TO BIDDING, NOTING EXISTING CONDITIONS AND EQUIPMENT. IF SAID EQUIPMENT IS NOT BEING REMOVED AS PART OF THE PROJECT OR IS NOTED AS EXISTING TO REMAIN AND IMPEDES PROVIDING PROPOSED EQUIPMENT AND OR PROVIDING PROPOSED SCOPE OF WORK, EQUIPMENT SHALL BE TEMPORARILY RELOCATED AND COMPLETELY REINSTALLED AFTER PROPOSED SCOPE OF WORK IS COMPLETED. THIS SHALL BE PART OF THE BASE BID AND CONTRACTOR(S) SHALL BID ACCORDINGLY. NO ADDITIONAL COMPENSATION WILL BE CONSIDERED FOR RELATED WORK OR COORDINATION WITH EXISTING CONDITIONS.

Revisions

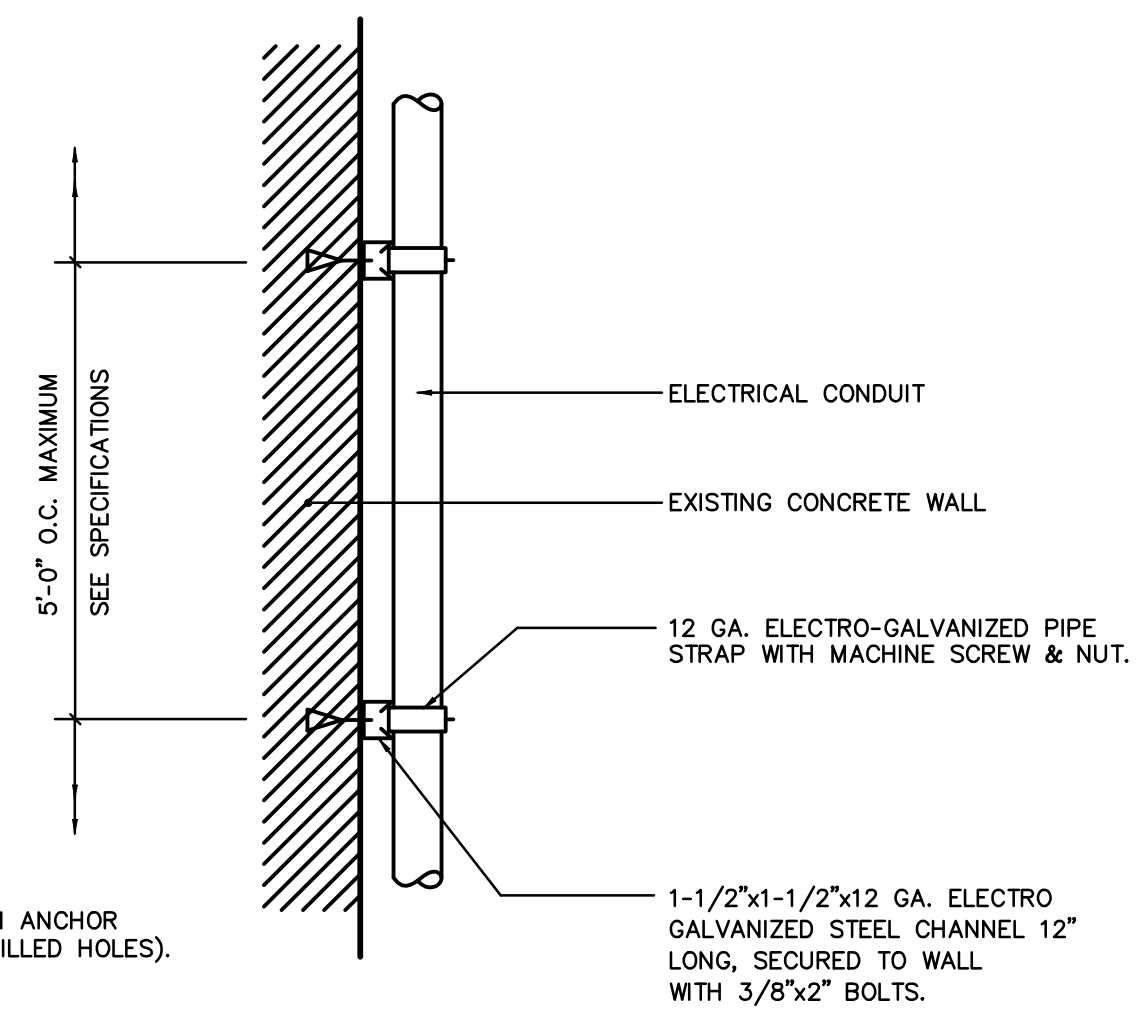

TYPICAL VERTICAL CONDUIT SUPPORT DETAIL
SCALE: N.T.S.

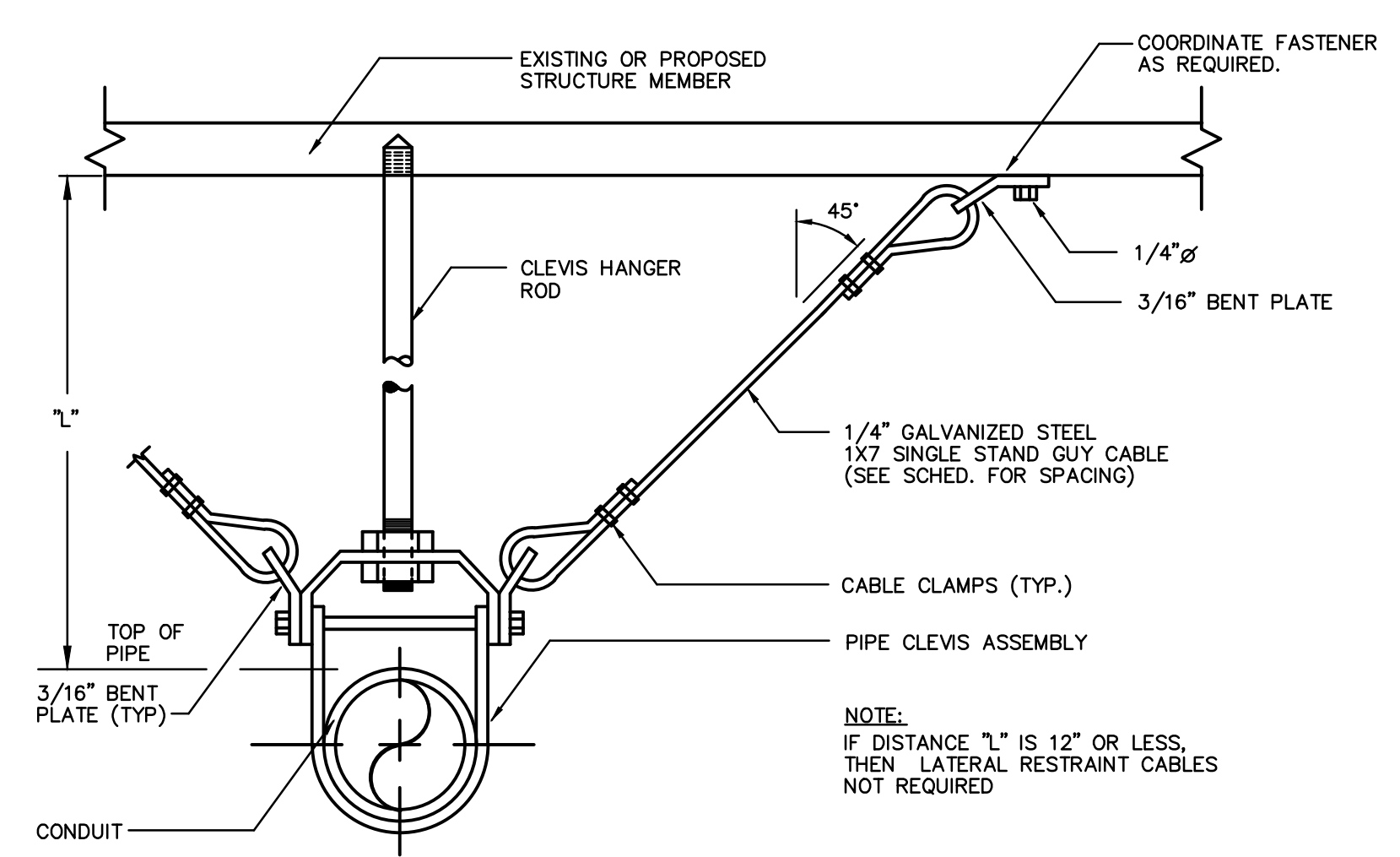

TYPICAL SEISMIC RESTRAINT ASSEMBLY OF SUSPENDED CONDUIT
SCALE: N.T.S.

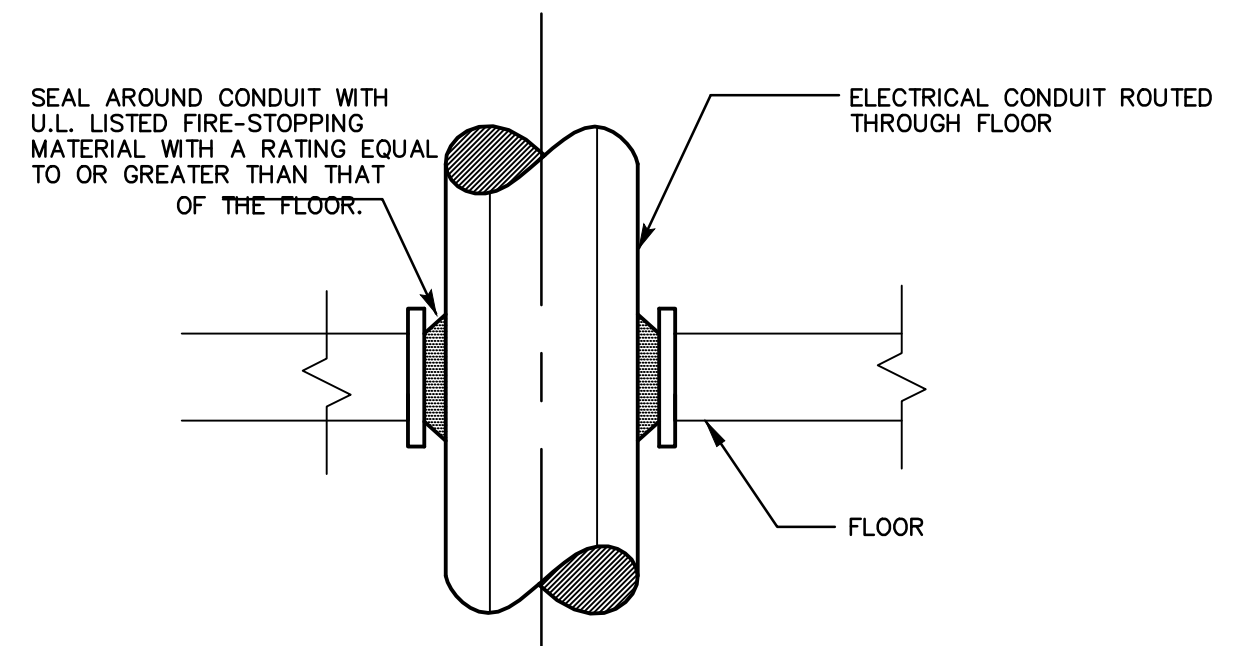

ASSEMBLY RATING
INSTALLATION ASSEMBLY SHALL PROVIDE AN APPROVED THROUGH-PENETRATION THAT HAS BEEN LISTED IN ACCORDANCE WITH ASTM E814

TYPICAL CONDUIT FLOOR PENETRATION DETAIL (UL XHEZ C-AJ-1008)
SCALE: N.T.S.

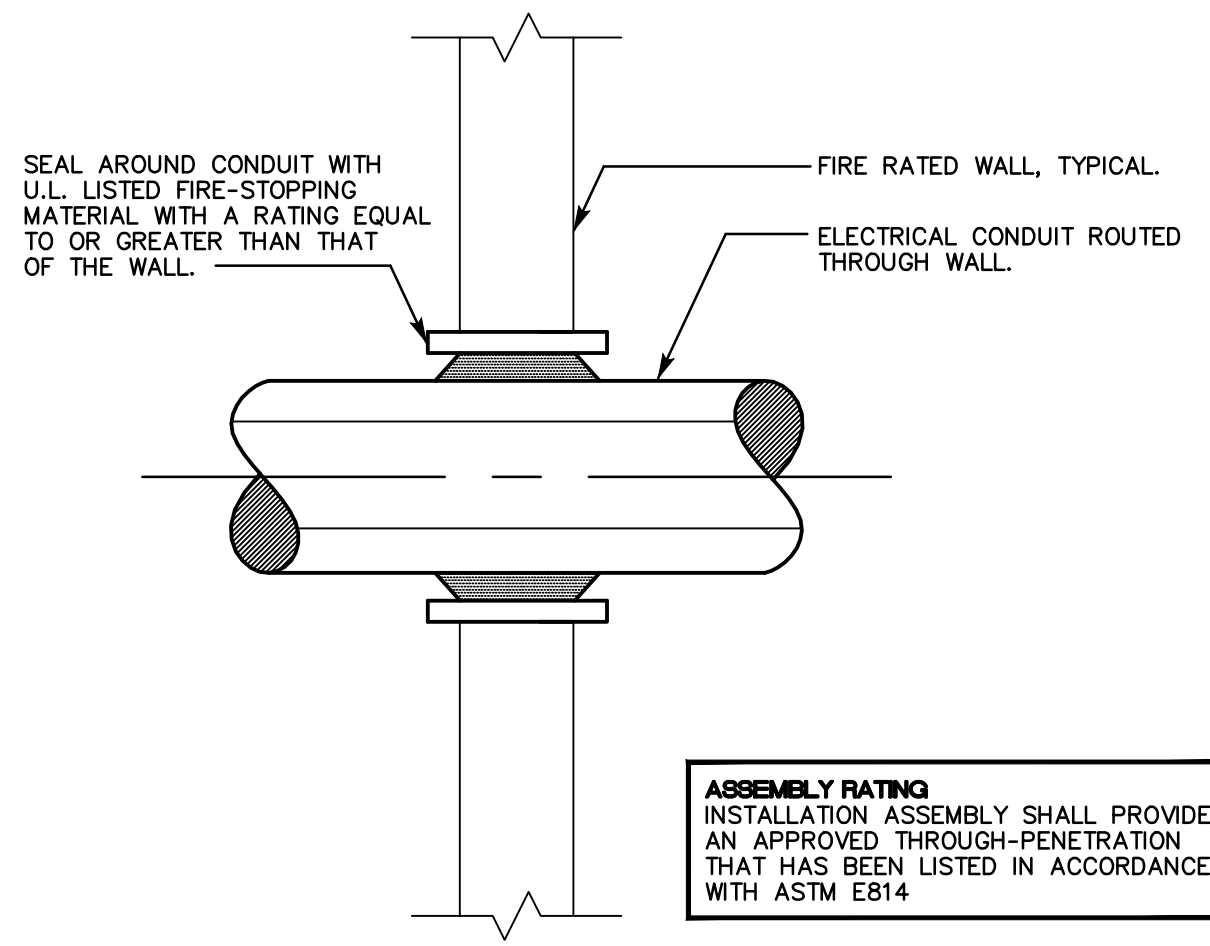

ASSEMBLY RATING
INSTALLATION ASSEMBLY SHALL PROVIDE AN APPROVED THROUGH-PENETRATION THAT HAS BEEN LISTED IN ACCORDANCE WITH ASTM E814

TYPICAL CONDUIT WALL PENETRATION DETAIL (UL XHEZ C-AJ-1008)
SCALE: N.T.S.

LUMINAIRE SCHEDULE					
LTG. CODE	DESCRIPTIONS	VOLTS	CATALOG NO./ MANUFACTURER	MOUNTING	LAMP (G.E. OR EQUAL)
A	12"x12" SURFACE MOUNTED, LOW PROFILE, VANDAL RESISTANT LED, HIGH IMPACT RESISTANT PEARLESCENT POLYCARBONATE LENS. 2500 LUMEN OUTPUT. 3500K COLOR. MATTE WHITE FINISH. 5 YEAR WARRANTY. UL LISTED WET LOCATIONS.	UNV	MS11FL-PP-MW-20L35K-DV KENALL LIGHTING	CEILING/SURFACE	LED
AE	FIXTURE TYPE A WITH 1000 LUMEN, 90 MINUTE EMERGENCY BATTERY PACK.	UNV	MS11FL-PP-MW-20L35K-DV-LEL-SA KENALL LIGHTING	CEILING/SURFACE	LED
B	15" FULL CUTOFF, VANDAL RESISTANT, EXTERIOR LED WALL PACK. CLEAR POLYCARBONATE LENS. 3100 LUMEN OUTPUT. TYPE IV OPTICS. 70CRI, 4000K COLOR TEMP. MATTE BLACK FINISH. 5 YEAR WARRANTY. UL LISTED WET LOCATIONS.	UNV	FN15-4-7-MB-24L40K7-DV KENALL LIGHTING	WALL/SURFACE	LED
BE	15" FULL CUTOFF, VANDAL RESISTANT, EXTERIOR LED WALL PACK. CLEAR POLYCARBONATE LENS. 3100 LUMEN OUTPUT. TYPE IV OPTICS. 70CRI, 4000K COLOR TEMP. INTEGRAL COLD WEATHER BATTERY PACK. MATTE BLACK FINISH. 5 YEAR WARRANTY. UL LISTED WET LOCATIONS.	UNV	FN15-4-7-MB-24L40K7-DV-CEL KENALL LIGHTING	WALL/SURFACE	LED
CE	3"x4" HIGH EFFICIENCY, LOW PROFILE LED STRIP LIGHT. 4000 NOMINAL LUMENS DELIVERED. 4000K COLOR. ENCLOSED LENS.	UNV	FSW440L840-UNV-DIM-EMLED SIGNIFY DAYBRITE	CEILING/SURFACE	LED
NOTES:					

EXHAUST FAN SCHEDULE	
EXHAUST FAN NO.	EF-1
SERVICE	BATHROOM
AIR FLOW (SCFM)	300
EXT. STATIC PRESS. (WG)	0.125
DRIVE TYPE	DIRECT
MOTOR WATTS	135
ELECT. CHARAC. (V/PH/Hz)	120/1/60
LOCAL DISCONNECT	YES
HOUSING MATERIAL	GALVANIZED STEEL
BACKDRAFT DAMPER	YES
DESIGN BASED MODEL	SP-A390
DESIGN BASED MANUFACTURER	GREENHECK
NOTES:	
1. SEE SPECIFICATIONS FOR FURTHER REQUIREMENTS. TYPICAL.	
2. INSTALL EXHAUST FANS AND ACCESSORIES PER MANUFACTURER'S INSTALLATION INSTRUCTION. TYPICAL.	
3. COORDINATE WITH DIVISION 16 AND ALL WORK WITH OTHER PROJECT DISCIPLINES. TYPICAL.	
4. PROVIDE ALUMINUM GRILLES. COORDINATE FINISH WITH ARCHITECT. TYPICAL.	
5. PROVIDE HANGING VIBRATION ISOLATOR KIT FOR EACH FAN. TYPICAL.	

ELECTRICAL SYMBOL LIST	
	PHOTOCELL
	TRANSFORMER
	SPECIAL PURPOSE CONNECTION
	DISCONNECT SWITCH
	BRANCH CIRCUIT HOMERUN (ARROWS INDICATE CIRCUIT NUMBERS)

- ### ELECTRICAL GENERAL NOTES
- SEE SPECIFICATIONS, DIVISION 26 ELECTRICAL.
 - PROVIDE A COMPLETE AND OPERATIONAL ELECTRICAL SYSTEM INCLUDING ALL NECESSARY MATERIAL, LABOR AND EQUIPMENT.
 - ELECTRICAL PLANS AND DETAILS AND ONE LINE DIAGRAMS SHOW THE GENERAL LOCATION AND ARRANGEMENT OF THE ELECTRICAL SYSTEM. THEY ARE DIAGRAMMATIC AND DO NOT SHOW ALL CONDUIT BODIES, CONNECTORS, BENDS, FITTINGS, HANGERS AND ADDITIONAL PULL AND JUNCTION BOXES.
 - PROVIDE LUMINAIRES, DEVICES, EQUIPMENT AS CALLED FOR.
 - ALL EQUIPMENT AND MATERIAL SHALL BE LABELED, LISTED AND INSTALLED IN ACCORDANCE WITH THEIR LISTING.
 - THE CONTRACTOR SHALL OBTAIN ALL REQUIRED PERMITS AND ARRANGE FOR ALL REQUIRED INSPECTIONS IN ACCORDANCE WITH STATE AND LOCAL GOVERNING AUTHORITIES.
 - ALL WORK SHALL BE DONE WITH LICENSED WORKMEN IN ACCORDANCE WITH STATE AND LOCAL GOVERNING AUTHORITIES.
 - THE DEFINITION OF ELECTRICAL TERMS USED SHALL BE AS DEFINED IN THE 2014 EDITION OF THE NATIONAL ELECTRICAL CODE (NEC WITH CT AMENDMENTS).
 - THE TERM "INDICATED" SHALL MEAN "AS SHOWN ON CONTRACT DOCUMENTS (SPECIFICATIONS, DRAWINGS AND RELATED ATTACHMENTS)".
 - THE TERM "PROVIDE" SHALL MEAN "TO FURNISH, INSTALL AND CONNECT COMPLETELY".
 - THE TERM "SIZE" SHALL MEAN ONE OR MORE OF THE FOLLOWING: LENGTH, CURRENT AND VOLTAGE RATING, NUMBER OF POLES, NEMA SIZE AND OTHER SIMILAR ELECTRICAL CHARACTERISTICS.
 - THE TERM "SPACE" ON PANELBOARD AND SWITCHBOARD SCHEDULES SHALL MEAN "PROVIDE SPACE TO INSTALL THE NUMBER OF POLES AND SIZE OF THE PROTECTIVE DEVICE INDICATED WITH ALL NECESSARY BUS AND FITTINGS TO INSTALL THE DEVICE AT SOME FUTURE DATE".
 - ELECTRICAL PLANS AND DETAILS DO NOT SHOW ALL INTERFERENCES AND CONDITIONS, VISIBLE AND/OR HIDDEN, THAT MAY EXIST; THUS REQUIRING THE CONTRACTOR TO INSPECT AND SURVEY THE SPACE BEFORE PERFORMING THE WORK.
 - COORDINATE ELECTRICAL WORK WITH OWNER.
 - COORDINATE ELECTRICAL WORK WITH OTHER DIVISIONS OF THIS PROJECT.
 - TURN OVER TO THE OWNER ALL MANUFACTURERS WARRANTIES FOR EQUIPMENT AND MATERIAL PROVIDED.
 - UNLESS OTHERWISE INDICATED, ALL ELECTRICAL EQUIPMENT HAS BEEN BASED ON GENERAL ELECTRIC PRODUCTS.
 - THE CONTRACTOR MAY SUBSTITUTE EQUIPMENT OF ANOTHER MANUFACTURER IF IT IS OF EQUAL QUALITY AND RATING, SUBJECT TO OWNER'S AND ENGINEER'S REVIEW AND ACCEPTANCE.
 - UNLESS OTHERWISE INDICATED, ALL ENCLOSURES FOR EQUIPMENT PROVIDED SHALL BE NEMA TYPE 1.
 - UNLESS OTHERWISE INDICATED, ALL CONDUCTORS TO BE COPPER THHN/THWN-2.
 - UNLESS OTHERWISE INDICATED, ALL OUTLET AND SWITCH BOXES TO BE CAST IRON WITH THREADED HUBS.
 - IN INTERIOR PROTECTED LOCATIONS, OUTLET AND SWITCH BOXES MAY BE STEEL.
 - UNLESS OTHERWISE INDICATED, PROVIDE HEAVY-DUTY GRADE, 20 AMPERE RECEPTACLES AND SWITCHES. ALL PLATES IN FINISHED AREAS TO BE BRUSHED STAINLESS STEEL. PLATES FOR SURFACE MOUNTED INTERIOR BOXES MAY BE STAMPED STEEL. PLATES EXPOSED TO WEATHER OR WATER TO BE GASKETED, WEATHERPROOF TYPE. COLOR BY ARCHITECT.
 - BEFORE SELECTING MATERIAL AND EQUIPMENT, AND PROCEEDING WITH WORK, INSPECT AREAS WHERE MATERIAL AND EQUIPMENT ARE TO BE INSTALLED TO INSURE SUITABILITY, AND CHECK NEEDED SPACE FOR PLACEMENT, CLEARANCES AND INTERCONNECTIONS.
 - BEFORE CUTTING OR DRILLING INTO BUILDING ELEMENTS, INSPECT AND LAYOUT WORK TO AVOID DAMAGING STRUCTURAL ELEMENTS AND BUILDING UTILITIES.
 - ALL WORK SHALL BE DONE IN ACCORDANCE WITH THE NATIONAL ELECTRIC CODE (NEC) ANSI/NFPA 70.
 - THE MEASUREMENT FROM ABOVE FINISHED FLOOR (AFF) SHALL BE TAKEN FROM THE FINISHED FLOOR SURFACE TO THE TOP OF WALL RECEPTACLES AND SWITCH BOXES, TO THE CENTER LINE OF WALL LIGHTING OUTLET BOXES, TO THE TOP OF WALL MOUNTED EQUIPMENT ENCLOSURES, TO THE CENTER LINE OF THE TOP MOST SWITCH HANDLE, OR TO THE LOWEST SURFACE OF CEILING LIGHTING FIXTURES OTHER CEILING MOUNTED EQUIPMENT.
 - UNLESS OTHERWISE INDICATED, ALL CONDUCTORS ARE NO. 12 AWG.
 - CONDUIT SIZE FOR INDICATED CONDUCTORS SHALL BE BASED ON CHAPTER 9 OF NEC.
 - THE CONTRACTOR MAY GROUP BRANCH CIRCUIT HOME RUN CONDUCTORS IN A SINGLE RACEWAY IN ACCORDANCE WITH NEC ARTICLE 300-17 AND ARTICLE 310.
 - ALL BLANK COVER PLATES TO BE STAINLESS STEEL.
 - WALL SWITCH BOXES SHALL BE MOUNTED 44 INCHES A.F.F. RECEPTACLES SHALL BE MOUNTED 18 INCHES A.F.F., UNLESS OTHERWISE NOTED.
 - PROVIDE TELECOMMUNICATIONS WIRING AND OUTLETS. COORDINATE WITH OWNERS IT DEPARTMENT.
 - PROVIDE ELECTRICAL WIRING TO ALL APPLIANCES AND MECHANICAL EQUIPMENT.
 - ALL MANUFACTURER'S WARRANTIES FOR EQUIPMENT AND MATERIALS PROVIDED TO BE TURNED OVER TO THE OWNER.

ELECTRICAL ABBREVIATIONS	
A	AMPERES
A.F.F.	ABOVE FINISHED FLOOR
AWG	AMERICAN WIRE GAUGE
C	CONDUIT
CIR	CIRCUIT
G	GROUNDING
HP	HORSEPOWER
KAIC	INTERRUPTING CAPACITY (KILOAMPERE)
KVA	KILOVOLT-AMPERE
KW	KILOWATT
NEC	NATIONAL ELECTRIC CODE
NEMA	NATIONAL ELECTRICAL MANUFACTURERS ASS.
P	POLE
UL	UNDERWRITER'S LABORATORY
UTIL	UTILITY
V	VOLTS
VA	VOLT-AMPERES
W	WATTS
#	WIRE SIZE IN AWG, OR MCM WHEN INDICATED

CONSULTANT:
SALAMONE & ASSOCIATES, P.C.
CONSULTING ENGINEERS
116 North Plains Industrial Road
Hartford, Connecticut 06102
Phone: (203) 281-6895 Fax: (203) 287-8728

RENOVATION TO EXISTING BATHROOM AT QUINNIPIAC PARK
 QUINNIPIAC PARK BATHROOMS 1325 CHESHIRE STREET, CHESHIRE, CT

Revisions

WOJAS.ARCH, LLC
5 Race Track Hollow
Middlefield, CT 06455
Phone: 860-930-5322
www.wojas.us
email: jan@wojas.us

MECHANICAL/ELECTRICAL SCHEDULES, DETAILS, SYMBOLS, NOTES AND ABBREVIATIONS

PROJ. NO. 2122-10	DRAWING NO.
SCALE: As Indicated	ME2
DATE: 3-7-2022	



Project Manual and Specifications

RENOVATION TO EXISTING BATHROOM AT QUINNIPIAC PARK

Bid #2122-10

Quinnipiac Park

Cheshire, CT 06411

Project #: 2122-10

March 7, 2022

RENOVATION TO EXISTING BATHROOM AT QUINNIPIAC PARK
Bid #2122-10

Division 1 - General Requirements
Section 01010 - Special Conditions
Section 01040 - Project Coordination
Section 01300 - Submittals and Product Substitutions
Section 01400 - Quality Control Services
Section 01500 - Temporary Facilities
Section 01600 - Reference Standards, Definitions, Materials and Equipment
Section 01620 - Storage and Protection
Section 01700 - Project Closeout
Section 01710 - Cleaning of New and Existing Spaces

Division 2 - Sitework
Section 02070 - Selective Demolition
Section 02075 - Cutting and Patching

Division 4 - Masonry
Section 04200 - Unit Masonry

Division 6 - Wood and Plastics
Section 06105 - Miscellaneous Carpentry

Division 7 - Thermal and Moisture Protection
Section 07920 - Joint Sealers

Division 9 - Finishes
Section 09900 - Painting

Division 10 - Specialties
Section 10155 - Toilet Compartments
Section 10200 - Louvers and Vents

Division 15 - Mechanical/Plumbing
SECTION 15010 BASIC MECHANICAL REQUIREMENTS
SECTION 15050 BASIC MECHANICAL MATERIALS AND METHODS
SECTION 15100 VALVES
SECTION 15140 SUPPORTS AND ANCHORS
SECTION 15250 MECHANICAL INSULATION
SECTION 15411 WATER DISTRIBUTION PIPING
SECTION 15420 DRAINAGE AND VENT SYSTEMS
SECTION 15440 PLUMBING FIXTURES
SECTION 15870 POWER VENTILATORS

Division 16 - Electrical
SECTION 16010 BASIC ELECTRICAL REQUIREMENTS

SECTION 16050	BASIC ELECTRICAL MATERIALS AND METHODS
SECTION 16060	ELECTRICAL DEMOLITION
SECTION 16110	RACEWAYS
SECTION 16120	WIRES AND CABLES
SECTION 16135	CABINETS, BOXES AND FITTINGS
SECTION 16143	WIRING DEVICES
SECTION 16170	ENCLOSED SWITCHES AND CIRCUIT BREAKERS
SECTION 16190	SUPPORTING DEVICES
SECTION 16195	ELECTRICAL IDENTIFICATION
SECTION 16452	GROUNDING
SECTION 16475	OVERCURRENT PROTECTIVE DEVICES
SECTION 16515	EXTERIOR LIGHTING
SECTION 16515	INTERIOR LIGHTING

End of index

SECTION 01010
SPECIAL CONDITIONS

PART 1 -GENERAL

1.1 RELATED DOCUMENTS

- A. Instructions to Bidders, AIA Document A201, "The General Conditions of the Contract for Construction," 15th Edition, 1997, the Supplementary General Conditions and Division 1, General Requirements, are a part of this Section and shall be binding on the Contractor and/or Subcontractor who performs this work. Note also all Addenda.

1.02 USE OF BUILDING BY THE OWNER

- a. The existing building will be occupied by the Owner during construction operation. The Contractor's attention is directed towards Section 01040, Project Coordination, for written description of the proposed construction scenario. All work must be coordinated with the Architect and the Owner to insure that satisfactory operational and environmental conditions are maintained during all phases of construction. In all cases the schedule / function of the school while classes are in session shall take precedence over construction activities.
- b. The Contractor shall develop a detailed construction schedule acceptable to the Owner.
- c. In general, construction must be phased to provide new space that is ready for occupancy before commencing work in existing areas to be altered. Work on the new areas must proceed in a manner to insure no permanent damage from the elements to existing adjacent spaces and no injury to occupants. Repair of any permanent damage shall be the Contractor's responsibility. Access to and exiting from the building may be temporarily relocated during various phases of construction. Safe egress from the existing building acceptable to the Fire Marshal and the Owner, must be maintained at all times.
- d. Contractor shall provide tight, secure, dust screens to separate all areas of the work and occupied spaces.

1.03 EXISTING CONDITIONS AND MEASUREMENTS

- a. Each Bidder will be held to have examined the premises and satisfied himself with the conditions which would in any manner affect the work under the Contract, and no later claims for extra compensation for labor, materials and equipment which could have been foreseen by such examination will be recognized. This Contractor shall take all necessary measurements for his work, at the site, and shall verify all measurements given on the Drawings.

1.04 INTENT

- a. These Specifications with the accompanying Drawings are intended to describe and illustrate all material, labor, and equipment necessary to complete the project.
- b. For convenience of reference, these Specifications are separated into titled Divisions and Sections. Such separations shall not, however, operate to make the Architect an arbiter to establish limits to Contracts between the Contractor and Subcontractors. The Divisions of the Specifications do not necessarily define the limits of the Contractor's subcontracts, the work of any one subcontract may include items specified in several Divisions or sections. The Contractor may sublet work as he sees fit, but it is his responsibility to see that all work shown on the Drawings and/or specified is completed in accordance with the Contract.
- c. All materials shall be furnished and all work shall be accomplished in strict accordance with the grades or standards of materials, standards of workmanship, and manufacturer's specifications listed or mentioned in these documents.
- d. The listing or mention of materials shall be sufficient indication that all such materials shall be furnished by the Contractor, in accordance with the grades or standards indicated, free from defects impairing strength, durability or appearance and in sufficient quantity for the proper and complete execution of the work, unless specifically stated otherwise.
- e. The listing or mention of any method of installation, erection, fabrication or workmanship shall not operate to make the contractor an agent, but shall be for the sole purpose of setting a standard of quality for the finished work. Contractor is free to use any alternate method, provided only that, prior to the start of the work, such alternate method is approved in writing by the Architect, as resulting in quality equal to that intended by these documents. Unless an alternate method is approved, all work shall be in strict accordance with all methods of installation, erection, fabrication and workmanship listed or mentioned herein.

1.05 CORRELATION OF DRAWINGS AND SPECIFICATIONS

- a. In general, the Specifications will describe the "quality" of the work and the Drawings, the "extent" of the work. The Drawings and Specifications are cooperative and supplementary, however, and each item of the work is not necessarily mentioned in both the Drawings and the Specifications. All work necessary to complete the project, so described, is to be included in this Contract.

- b. In case of disagreement between Drawings and Specifications, or within either document itself, the better quality or greater quantity of work for decision and/or adjustment. Any work done by the Contractor without consulting the Architect, when the same requires a decision, shall be done at the Contractor's risk.
- c. Omissions or Errors: If any omissions or errors are noted or instructions at variance with the obvious intent of the documents, it is the responsibility of the Contractor to call them to the Architect's attention before signing the Contract.

1.06 INTERPRETATION OF "OR EQUAL"

- a. The use of trade names, with a notation such as "or equal" in these Specifications is to establish quality required; there is no attempt to limit competitive bidding, but in like manner quality specified will be rigidly maintained.
- b. The words "approved," "equal to," "as directed," etc., are interpreted and will be taken to mean "to the satisfaction of the Architect."
- c. Where three or more proprietary names are specified, and the words "or equal" are omitted, no substitute products will be considered. Bids must be based on one of the named products.

1.07 WORK SCHEDULE AND COST BREAKDOWN

- a. The work shall be promptly started and shall be manned to guarantee completion on or before the time stated in the Bid Proposal. The Contractor shall furnish to the Architect a project schedule showing an anticipated schedule for the designated period. The project plan shall be presented prior to beginning work.
- b. If, in the opinion of the Architect, it becomes necessary for maintaining the schedule and for the completion of the school within the specified time, to work additional men, Contractors must immediately do so upon written request.
- c. **Submit immediately after the Contract is let, an itemized breakdown of estimated cost in detail.**

1.08 TEMPORARY UTILITIES

- a. General - All concerned with furnishing utilities for use on the project as specified in this section are cautioned to determine location of sources of supply and conditions under which services can be brought to points of

use on the site. Each shall inspect premises and drawings for requirements of local installations and shall ascertain rules and fees under which various public private or municipal utilities will supply service. Upon completion of project, remove all temporary work.

- b. Water - Existing service is available for the Contractor's use.
- c. Electrical Service
 - 1. Existing service is available for Contractor's use. The Contractor shall arrange and pay for temporary connections.
 - 2. Contractors shall be responsible for furnishing such light bulbs and extension cords as may be essential to the execution of their respective branches of the work and for extensions of lines to sheds or to power tools and remote areas which cannot be reached with extension cords.
- d. Utility Charges for electric power and water service will be paid by the Owner.
- e. Job Telephone - The Contractor shall provide telephone service for use of all employed about the building and shall pay the installation, maintenance, change in location, removal and all charges for use of this telephone, except that charges for long distance calls shall be paid for by the person making the same. The telephone shall remain until the full completion of the work.

1.09 TOILET FACILITIES

- a. The General Contractor shall provide portable toilet facilities for the use of their work forces. It shall be the responsibility of the General Contractor to insure these toilet facilities are kept clean and in sanitary conditions.

1.10 PROTECTION

- a. Contractor shall at all times protect the building from damages from rain water. Contractor shall provide all equipment and enclosures to insure this protection.
- b. Contractor shall construct and maintain all necessary temporary drainage and do all pumping necessary to keep excavation and below grade construction free of water.
- c. During cold weather, Contractor shall remove all snow and ice as may be required for proper protection and prosecution of the work.

- d. Contractor shall provide all shoring, bracing and sheeting as required for safety and for proper execution of work and have same removed when work is completed.
- e. During cold weather, Contractor shall protect all work from damage. If low temperatures make it impossible to continue operations safely in spite of cold weather precautions, Contractor shall cease work and shall so notify Architect. The Contractor shall be responsible for the repair and/or replacement, as may be required, of all work damaged from frost, freezing or any elements of the weather.
- f. Protection at Night and when Work is not in Progress. The Contractor shall be solely responsible for damage, loss or liability, due to the theft or vandalism when work is not in progress at night, weekends, or holidays.
- g. Existing Exitways shall be maintained to provide safe egress from occupied portions of the building at all times. The Contractor will be required to erect temporary enclosures, stairs, and ramps that may be required to accomplish safe passage through construction. Exiting shall be satisfactory to both the Fire Marshal and the owner.
- h. Fire Protection - All fire used within the structure for working purposes shall be extinguished when not in use. No flammable material shall be stored in the structure in excess of amounts allowed by the authorities. No gasoline shall be stored in or close to the building at any time.
- i. Precaution must be exercised at all times for the protection of persons and property. The safety provisions of applicable laws, school and construction codes must be observed; Contractor shall take or cause to be taken such additional safety and health measures as are reasonably necessary. Machinery, equipment and other hazards, guarded in accordance with the safety provisions of the Manual of Accident Prevention in Construction published by the Associated General Contractors of America, to the extent that such provisions are not in contravention of applicable laws.
- j. It shall be the responsibility of the Contractor to protect and preserve, in operating condition, all utilities traversing the work area. Damage to any utility due to work under this Contract shall be repaired to the satisfaction of the Architect at no additional cost to the Owner.

1.11 USE OF PREMISES, SPECIAL WORKING CONDITIONS

- a. The Contractor shall confine his apparatus, storage of materials, supplies, equipment and operations to the areas bounded by the Contract and on-site limits as directed by the Architect. Coordination with the owner is essential in this matter.

- b. The Contractor shall be responsible for keeping the premises clean and shall pick up rubbish and debris daily.

1.12 MAINTENANCE OF TRAFFIC AND EXITWAYS

- a. On-site and off-site traffic and exitways shall not be blocked by construction vehicles, parked cars, material storage and other construction operations. Interior and exterior building exitway shall be maintained at all times during the work day.

1.13 SAMPLES

- a. All materials that will be used in the construction of this project are subject to the approval of the Architect. All samples required by the Specifications or by the above requirements shall be submitted for approval. Where color selections are made, complete samples shall be furnished to the Architect.

1.14 EQUIPMENT AND HOISTS

- a. The Contractor shall provide at his own expense and risk, all tools, equipment, apparatus, and temporary work that may be required for the execution of the work under his Contract.
- b. The Contractor shall provide temporary hoists with power and attendance for same as required to handle his own materials and rubbish.

1.15 FIRE EXTINGUISHER

- a. Provision of fire extinguisher in the area under construction is required from the standpoint of controlling incipient fires promptly.

1.16 REPAIRS

- a. Contractor shall make all repairs to existing streets, walks, curbs, grassed areas, etc., made necessary by this work.

1.17 GENERAL COORDINATION

- a. There shall be cooperation and coordination with respect to time, space, work, etc., between the General Contractor, Subcontractors and all other Contractors and no claim for extra compensation or extension of Contract time will be allowed for conditions resulting from lack of said cooperation and coordination.

- b. The Contractor shall promptly notify the Architect of all errors, omissions or discrepancies which he finds on the Contract Documents and he shall not proceed with the work involved in such errors, omissions, or discrepancies until instructions are given by the Architect. The Contractor shall be responsible for all work erroneously installed prior to receiving said instructions.

1.18 DELIVERY, STORAGE AND HANDLING

- a. All materials and equipment shall be so delivered, stored and handled as to prevent intrusion of foreign materials and damage by weather or breakage. Packaged materials shall be delivered and stored in original packages. Packages opened for Architect's inspection shall be resealed until ready for use. Packages, materials and equipment showing evidence of damage shall be rejected.
- b. All materials which could be affected by dampness shall be stored in suitable substantial watertight storage facilities maintained in good condition throughout their use.
- c. Rigid insulation board shall not be stored within the building. Provision shall be made for its protection from the weather and vandals elsewhere on the site.

1.19 FINAL CLEANING

- a. All accumulated rubbish shall be removed from the building and points immediately adjacent thereto by the General Contractor who shall transport same from premises. Flammable rubbish shall not be burned on the premises. It shall be hauled away. No rubbish shall be deposited as fill on premises.
- b. Leave the work area clean and ready for use. If the Contractor fails to clean up, the Owner may do so and the cost thereof shall be charged to the Contractor.
- c. See Section 01710 for additional requirements.

1.20 GUARANTEE

- a. If, in the Contractor's opinion, any work is shown on the Drawings or called for in the Specifications in such a manner as to make it impossible for him to produce and guarantee a first-class piece of work, he shall refer the same to the Architect before proceeding.
- b. The Contractor and each Subcontractor shall guarantee that all materials and workmanship shall be free from original defects or against injury from proper and usual wear when used for purposes intended for one year after date of final certificate. Where guarantees or warranties are written in any

of the divisions for longer terms, such longer terms shall apply from this date.

- c. The Contractor shall, in case of work performed by their Subcontractors or where guarantees are required, secure guarantees from said Subcontractors and deliver copies of same to the Architect upon completion of the work.
- d. All portions of the work shall also be maintained in perfect condition during this period. Such written guarantees as may be requested shall be submitted in duplicate at the completion of the work. These will be supplementary to and not in any way canceling specific guarantees which apply to various portions of the work.
- e. See Specifications Sections for additional Guarantee requirements.

1.21 SOCIAL SECURITY TAXES

- a. The Contractor and each Subcontractor shall pay the taxes measured by the wages of all their employees as required by the Federal Social Security Act and all amendments thereto, and accept the exclusive liability for said taxes. The Contractor shall also indemnify and hold the owner harmless on account of any tax measured by the wages aforesaid of employees of the Contractor and his subcontractors, assessed against of the Owner under authority of said law.

1.22 UNEMPLOYMENT INSURANCE

- a. The Contractor and each Subcontractor shall pay unemployment insurance measured by the wages of his employees as required by law and accept the exclusive liability for said contributions. The Contractor shall also indemnify and hold harmless the owner on account of any contribution measured by the wages of aforesaid employees of the Contractor and his Subcontractors, assessed against the Owner under authority of law.

1.23 OCCUPATIONAL SAFETY AND HEALTH ACT (OSHA)

- a. The Contractor shall comply with the requirements of the Occupational Safety and Health Act (OSHA) of 1970 and the Construction Safety Act of 1969, including all standards and regulations which have been promulgated by the Governmental Authorities which administer such Acts and said requirements, standards and regulations are incorporated herein by reference.
- b. The Contractor shall comply with said regulations, requirements and standards and require and be directly responsible for compliance

therewith on the part of his agents, employees, material men and Subcontractors; and shall directly receive and be responsible for all citations, assessments, fines or penalties which may be incurred by reason of his agents, employees, material men or Subcontractors failing to so comply.

- c. The Contractor shall indemnify the Owner and Architect and save them harmless from any and all losses, costs and expenses, including fines and reasonable attorney's fees incurred by the owner and Architect by reason of the real or alleged violation of such laws, ordinances, regulations and directives, Federal, State, and Local, which are currently in effect or which become effective in the future, by the Contractor, his Subcontractors or material men.

1.24 JOB MEETINGS

- a. Meetings conducted at the job site by the Architect's representative for the purpose of coordinating and observing the work shall be mandatory for the Contractor and/or his superintendent. Also, at times, the Architect's representative will designate certain Subcontractors to attend.

1.25 LIST OF CONTACTS

- a. Contractor shall furnish Owner a list of persons to contact with telephone numbers for emergency use during construction period (off hours, weekends, holidays).

1.26 PLANS AND SPECIFICATIONS AT THE SITE

- a. **The Contractor shall maintain at the site one copy of all Drawings, Specifications, Addenda, approved shop drawings, change orders and other modifications, schedules, and instructions in good order and marked to record all changes made during construction. These shall be available at all times to the Architect or his authorized representatives.**
- b. As-Built Drawing Documentation - Carefully note that the Contractor is responsible for maintaining a record set of Contract Documents clearly marking all revisions, alterations, corrections, modifications, substitutions, etc., resulting from changes undertaken during the course of construction. At the conclusion of the project, the Contractor shall formally issue to the Architect a set of Contract Documents with all such As-built changes clearly marked and recorded.

1.27 DRAWINGS FURNISHED

- a. The Drawings and Specifications can be downloaded from the Towns website. The Contractor shall pay the cost of reproduction.

END OF SECTION 01010

SECTION 01040
PROJECT COORDINATION

PART 1 -GENERAL

1.1 RELATED DOCUMENTS

- A. Instructions to Bidders, AIA Document A201, "The General Conditions of the Contract for Construction," 15th Edition, 1997, the Supplementary General Conditions and Division 1, General Requirements, are a part of this Section and shall be binding on the Contractor and/or Subcontractor who performs this work. Note also all Addenda.

1.2 SUMMARY OF WORK

- a. The intent of this bid is to complete the work defined in the Contract Documents. The selected General Contractor must work harmoniously with the Owner to complete the Work within the calendar days noted in the Proposal.
- b. Portions of this building will be occupied and must remain fully operational throughout the construction period. This section of the specification contains a suggested Construction Phasing Plan which illustrates an approach to the renovations with respect to the operational requirements of the school. The Contractor will be required to establish and present to the Architect in writing for approval, his own phasing program that will allow the Contractor to complete the most disruptive work within the building during school vacation periods and when school is not in session.
- c. The Contractor shall prepare a detailed construction schedule which shall be presented to the Architect and the Owner for their review, comments and approval. The schedule must clearly demonstrate the proper sequencing of construction and relocation activities and how operational and environmental conditions will be satisfactorily maintained in all occupied spaces.
- d. Contractor shall provide tight, secure, dust screens to separate all areas of the work and occupied spaces.
- e. All work must be coordinated with the Architect and the School administration to insure satisfactory operational conditions. The Contractor will be required to coordinate and schedule his work to keep a minimum of the facilities shut down at any specific time. Any area that must be shut down may be only with the approval of and during the time designated by the Owner. The Contractor shall phase his work, as required, in the building. The Contractor shall insure safe access to

occupied areas by the employees, students and public. The Contractor shall insure that heat and all other utilities are provided to these areas. Repair of any damage to existing facilities and equipment resulting from interrupted utilities, lack of heat, or Contractor's work in the areas shall be Contractor's responsibility. Also, repair of any damage to services and utilities as a result of the work shall be the Contractor's responsibility. Contractor shall insure safe egress and security of existing areas and equipment during the construction. Existing exitways shall be maintained to provide safe egress from occupied portions of the building at all times.

- f. The Contractor shall restrict the parking of workmen and construction vehicles and the storage of construction materials to a suitable parking area to be determined during a pre-construction conference.

END OF SECTION 01040

SECTION 01300
SUBMITTALS AND PRODUCT SUBSTITUTIONS

PART 1 -GENERAL

1.1 RELATED DOCUMENTS

- A. Instructions to Bidders, AIA Document A201, "The General Conditions of the Contract for Construction," 15th Edition, 1997, the Supplementary General Conditions and Division 1, General Requirements, are a part of this Section and shall be binding on the Contractor and/or Subcontractor who performs this work. Note also all Addenda.

1.2 SUMMARY

- A. This Section specifies administrative and procedural requirements for submittals required for performance of the Work, including;
1. Schedule of Values.
 2. Shop Drawings.
 3. Product Data.
 4. Samples.
- B. This Section specifies administrative and procedural requirements for handling requests for substitutions made after award of the Contract.
- C. Administrative Submittals: Refer to other Division-1 Sections and other Contract Documents for requirements for administrative submittals. Such submittals include, but are not limited to:
1. Applications for payment.
 2. Insurance certificates.
 3. List of Subcontractors.
- D. Inspection and test reports are included in Section 01400 "Quality Control Services."

1.3 SUBMITTAL PROCEDURES

- A. Coordination: Within 15 days of the Contract award, submit to the Architect a comprehensive Submittals listing each item to be submitted and the date proposed to be submitted. Coordinate with the Architect in the preparation and processing of submittals with performance of construction activities. Transmit each submittal sufficiently in advance of performance of related construction activities to avoid delay.

1. Coordinate each submittal with fabrication, purchasing, testing, delivery, other submittals and related activities that require sequential activity.
 2. Coordinate transmittal of different types of submittals for related elements of the Work so processing will not be delayed by the need to review submittals concurrently for coordination.
 - a. The Architect reserves the right to withhold action on a submittal requiring coordination with other submittals until related submittals are received.
 - b. Coordinate transmittal of all submittals requiring color selection so that comprehensive selection can be processed.
 3. Processing: Allow sufficient review time so that installation will not be delayed as a result of the time required to process submittals, including time for re-submittals.
 - a. Allow two weeks for initial review. Allow additional time if processing must be delayed to permit coordination with subsequent submittals. The Architect will promptly advise the General Contractor when a submittal being processed must be delayed for coordination.
 - b. If an intermediate submittal is necessary, process the same as the initial submittal.
 - c. Allow two weeks for reprocessing each submittal.
 - d. No extension of Contract Time will be authorized because of failure to transmit submittals to the Architect sufficiently in advance of the Work to permit processing.
- B. Submittal Preparation: Place a permanent label or title block on each submittal for identification. Indicate the name of the entity that prepared each submittal on the label or title block.
1. Provide a space approximately 4" x 5" on the label or beside the title block on Shop Drawings to record the Contractor's review and approval markings and the action taken.
 2. Include the following information on all submittals:
 - a. Name of item being submitted.
 - b. Number and title of appropriate Specification Section.
 - c. Drawing number and detail references, as appropriate.
 - d. Name of manufacturer.
 - e. Name, address and telephone number of supplier.
 - f. Bid Package number and name.
 - g. Project Name.
 - h. Date.
 - i. Name, address and telephone number of Contractor.

- j. Name, address and telephone number of Subcontractor.
 - k. Name, address and telephone number of Architect.
- C. Submittal Transmittal: Package each submittal appropriately for transmittal and handling. Transmit each submittal from Contractor to Architect using a transmittal form. Submittals received from sources other than the Contractor will be returned without action.
- D. **The electronically submitting any documents through email in the form of PDF is preferred.**
- E. Should the contractor choose to submit hard copies, the number of copies should be: six (6) copies of all shop drawings and product data, of which three (3) will be returned to Contractor. Submit one (1) each of all samples.

1.4 DEFINITIONS

- A. Substitutions: Requests for changes in products, materials, equipment, and methods of construction required by Contract Documents proposed by the Contractor after award of the Contract are considered requests for "substitutions." The following are not considered substitutions:
- 1. Substitutions requested by Bidders during the bidding period, and accepted prior to award of Contract, are considered as included in the Contract Documents and are not subject to requirements specified in this Section for substitutions.
 - 2. Revisions to Contract Documents requested by the Owner or Architect.
 - 3. Specified options of products and construction methods included in Contract Documents.
 - 4. The Contractor's determination of and compliance with governing regulations and orders issued by governing authorities.

1.5 SCHEDULE OF VALUES

- A. Coordinate preparation of the Schedule of Values with preparation of the Construction Managers Construction Schedule.
- 1. Correlate line items in the Schedule of Values with other required administrative schedules and forms, including:
 - a. Construction Managers construction schedule.
 - b. Application for Payment form.
 - c. List of subcontractors.

2. Submit the Schedule of Values to the Architect at the earliest feasible date, but in no case later than seven (7) days before the date scheduled for submittal of the initial Application for Payment.
- B. Format and Content: Use the Project Manual Table of Contents as a guide to establish the format for the Schedule of Values.
1. Forms: Use AIA Document G702 and Continuation Sheets G703, as the form for the Schedule of Values.
 2. Identification: Include the following Project identification on the Schedule of Values:
 - a. Project name and location.
 - b. Name of the Architect.
 - c. Project number.
 - d. Contractor's name and address.
 - e. Date of submittal.
 3. Arrange the Schedule of Values in a tabular form with separate columns to indicate the following for each item listed:
 - a. Generic name.
 - b. Related Specification Section.
 - c. Change Orders (numbers) that have affected value.
 - d. Dollar value.
 - e. Percentage of Contract Sum to the nearest one-hundredth percent, adjusted to total 100 percent.
 4. Provide a breakdown of the Contract Sum in sufficient detail to facilitate continued evaluation of Applications for Payment and progress reports. Break principal subcontract amounts down into several line items.
 5. Round amounts off to the nearest whole dollar; the total shall equal the Contract Sum.
 6. For each part of the Work where an Application for Payment may include materials or equipment, purchased or fabricated and stored, but not yet installed, provide separate line items on the Schedule of Values for initial cost of the materials, for each subsequent stage of completion, and for total installed value of that part of the Work.
 7. Show temporary facilities and other major cost items that are not direct cost of actual work-in-place as separate line items in the Schedule of Values.

1.6 SHOP DRAWINGS

- A. Submit newly prepared information, drawn to accurate scale. Highlight, encircle, or otherwise indicate deviations from the Contract Documents.

Do not reproduce Contract Documents or copy standard information as the basis of Shop Drawings. Standard information prepared without specific reference to the Project is not considered Shop Drawings.

- B. Shop Drawings include fabrication and installation drawings, setting diagrams, schedules, patterns, templates and similar drawings. Include the following information:
1. Dimensions.
 2. Identification of products and materials included.
 3. Compliance with specified standards.
 4. Notation of coordination requirements.
 5. Notation of dimensions established by field measurement.
 6. Sheet Size: Except for templates, patterns and similar full size Drawings, submit Shop Drawings on sheets at least 8 ½" x 11", but no larger than 30" x 42".
 7. Do not use Shop Drawings without an appropriate final stamp indicating action taken in connection with construction.

1.7 PRODUCT DATA

- A. Collect Product Data into a single submittal for each element of construction or system. Product Data includes printed information such as manufacturer's installation instructions, catalog cuts, standard color charts, roughing-in diagrams and templates, standard wiring diagrams and performance curves. Where Product Data must be specially prepared because standard printed data is not suitable for use, submit as "Shop Drawings."
1. Mark each copy to show applicable choices and options. Where printed Product Data includes information on several products, some of which are not required, mark copies to indicate the applicable information. Include the following information:
 - a. Manufacturer's printed recommendations.
 - b. Compliance with recognized trade association standards.
 - c. Compliance with recognized testing agency standards.
 - d. Application of testing agency labels and seals.
 - e. Notation of dimensions verified by field measurement.
 - f. Notation of coordination requirements.
 2. Do not submit Product Data until compliance with requirements of the Contract Documents has been confirmed.
 3. Submittals: Submit copies of each required submittal; submit additional copies where required for maintenance manuals.

- a. Unless noncompliance with Contract Document provisions is observed, the submittal may serve as the final submittal.
4. Distribution: Furnish copies of final submittal to Architect for distribution to installers, subcontractors, suppliers, manufacturers, fabricators, and others required for performance of construction activities.
 - a. Do not proceed with installation until an approved copy of Product Data applicable is in the installer's possession.
 - b. Do not permit use of unmarked copies of Product Data in connection with construction.

1.8 SAMPLES

- A. Submit full-size, fully fabricated Samples cured and finished as specified and physically identical with the material or product proposed. Samples include partial sections of manufactured or fabricated components, cuts or containers of materials, color range sets, and swatches showing color, texture and pattern.
 1. Mount, display, or package samples in the manner specified to facilitate review of qualities indicated. Prepare samples to match the Architect's sample. Include the following:
 - a. Generic description of the sample.
 - b. Sample source.
 - c. Product name or name of manufacturer.
 - d. Compliance with recognized standards.
 - e. Availability and delivery time.
 2. Submit samples for review of kind, color, pattern, and texture, for a final check of these characteristics with other elements, and for a comparison of these characteristics between the final submittal and the actual component as delivered and installed.
 - a. Where variation in color, pattern, texture or other characteristics are inherent in the material or product represented, submit multiple units that show approximate limits of the variations.
 - b. Refer to other Specification Sections for requirements for samples that illustrate workmanship, fabrication techniques, details of assembly, connections, operation and similar construction characteristics.

3. Preliminary submittals: Where samples are for selection of color, pattern, texture or similar characteristics from a range of standard choices, submit a full set of choices for the material or product.
 - a. Preliminary submittals will be reviewed with the Architect indicating selection or other action.
 - b. Unless noncompliance with Contract Document provisions is observed, the submittal may serve as the final submittal.
4. Submittals: Except for samples illustrating assembly details, workmanship, fabrication techniques, connections, operation and similar characteristics, samples will not be returned, unless so requested in advance.
5. Maintain sets of returned samples, at the Project site, for quality comparisons throughout the course of construction.
 - a. Comply with submittal requirements to the fullest extent possible. Process transmittal forms to provide a record of activity.

1.9 SUBMITTALS

- A. Substitution Request Submittal: Requests for substitution will be considered if received within 60 days after commencement of the Work. Requests received more than 60 days after commencement of the Work may be considered or rejected at the discretion of the Architect.
 1. Submit 3 copies of each request for substitution for consideration. Submit requests in the form and in accordance with procedures required for Change Order proposals.
 2. Identify the product, or the fabrication or installation method to be replaced in each request. Include related Specification Section and Drawing numbers, complete documentation showing compliance with the requirements for substitutions, and the following information, as appropriate:
 - a. Product Data, including Drawings and descriptions of products, fabrication and installation procedures.
 - b. Samples, where applicable or requested.
 - c. A detailed comparison of significant qualities of the proposed substitution with those of the work specified. Significant qualities may include elements such as size, weight, durability, performance and visual effect.
 - d. Coordination information, including a list of changes or modifications needed to other parts of the Work and to construction performed by the Owner and separate

- Contractors, that will become necessary to accommodate the proposed substitution.
- e. A statement indicating the substitution's effect on the Contractor's Construction Schedule compared to the schedule without approval of the substitution. Indicate the effect of the proposed substitution on overall Contract Time.
 - f. Cost information, including a proposal of the net change, if any in the Contract Sum.
 - g. Certification by the Contractor that the substitution proposed is equal-to or better in every significant respect to that required by the Contract Documents, and that it will perform adequately in the application indicated. Include the Contractor's waiver of rights to additional payment or time, that may subsequently become necessary because of the failure of the substitution to perform adequately.
3. Architect's Action: Within one week of receipt of the request for substitution, the Architect will request additional information or documentation necessary for evaluation of the request. Within 2 weeks of receipt of the request, or one week of receipt of the additional information or documentation, whichever is later, the Architect will notify the General Contractor of acceptance or rejection of the proposed substitution. If a decision on use of a proposed substitute cannot be made or obtained within the time allocated, use the product specified by name.

1.10 ARCHITECT'S ACTION

- A. Except for submittals for record, information or similar purposes, where action and return is required or requested, the Architect will review each submittal, mark to indicate action taken, and return promptly.
 1. Compliance with specified characteristics is the Contractor's responsibility.
- B. Action Stamp: The Architect will stamp each submittal with a uniform, self-explanatory action stamp. The stamp will be appropriately marked, to indicate the action taken:
 1. Final Unrestricted Release: Where submittals are marked "Approved," that part of the Work covered by the submittal may proceed provided it complies with requirements of the Contract Documents; final acceptance will depend upon that compliance.
 2. Final-But-Restricted Release: When submittals are marked "Approved as Corrected," that part of the Work covered by the submittal may proceed provided it complies with notations or

- corrections on the submittal and requirements of the Contract Documents; final acceptance will depend on that compliance.
3. Returned for Resubmittal: When submittal is marked “Not Approved, Revise and Resubmit,” do not proceed with that part of the Work covered by the submittal, including purchasing, fabrication, delivery, or other activity. Revise or prepare a new submittal in accordance with the notations; resubmit without delay. Repeat if necessary to obtain a different action mark.
 - a. Do not permit submittals marked “Not Approved, Revise and Resubmit” to be used at the Project site, or elsewhere where Work is in progress.
 4. Other Action: Where a submittal is primarily for information or record purposes, special processing or other activity, the submittal will be returned, marked “Action Not Required”.

PART 2 - PRODUCTS

2.1 SUBSTITUTIONS

- A. Conditions: The Contractor’s substitution request will be received and considered by the Architect when one or more of the following conditions are satisfied, as determined by the Architect; otherwise requests will be returned without action except to record noncompliance with these requirements.
 1. Extensive revisions to Contract Documents are not required.
 2. Proposed changes are in keeping with the general intent of Contract Documents.
 3. The request is timely, fully documented and properly submitted.
 4. The request is directly related to an “or equal” clause or similar language in the Contract Documents.
 5. The specified product or method of construction cannot be provided within the Contract Time. The request will not be considered if the product or method cannot be provided as a result of failure to pursue the Work promptly or coordinate activities properly.
 6. The specified product or method of construction cannot receive necessary approval by a governing authority, and the requested substitution can be approved.
 7. A substantial advantage is offered the owner, in terms of cost, time, energy conservation or other considerations of merit, after deducting offsetting responsibilities the Owner may be required to bear. Additional responsibilities for the Owner may include additional compensation to the Architect for redesign and

evaluation services, increased cost of other construction by the Owner or separate Contractors, and similar considerations.

8. The specified product or method of construction cannot be provided in a manner that is compatible with other materials, and where the Contractor certifies that the substitution will overcome the incompatibility.
 9. The specified product or method of construction cannot be coordinated with other materials, and where the Contractor certifies that the proposed substitution can be coordinated.
 10. The specified product or method of construction cannot provide a warranty required by the Contract Documents and where the Contractor certifies that the proposed substitution provide the required warranty.
- B. The Contractor's submittal and Architect's acceptance of Shop Drawings, Product Data or Samples that relate to construction activities not complying with the Contract Documents does not constitute an acceptable or valid request for substitution, nor does it constitute approval.

PART 3 - EXECUTION (Not Applicable).

END OF SECTION 01300

SECTION 01400
QUALITY CONTROL SERVICES

PART 1 -GENERAL

1.1 RELATED DOCUMENTS

- A. Instructions to Bidders, AIA Document A201, "The General Conditions of the Contract for Construction," 15th Edition, 1997, the Supplementary General Conditions and Division 1, General Requirements, are a part of this Section and shall be binding on the Contractor and/or Subcontractor who performs this work. Note also all Addenda.

1.2 SUMMARY

- A. This Section specifies administrative and procedural requirements for quality control services.
- B. Quality control services include inspections and tests and related actions including reports, performed by independent agencies, governing authorities, and the Contractor. They do not include Contract enforcement activities performed by the Architect.
- C. Inspection and testing services are required to verify compliance with requirements specified or indicated. These services do not relieve the Contractor of responsibility for compliance with Contract Document requirements.
- D. Requirements of this Section relate to customized fabrication and installation procedures, not production of standard products.
 - 1. Specific quality control requirements for individual construction activities are specified in the Sections that specify those activities. Those requirements, including inspections and tests, cover production of standard products as well as customized fabrication and installation procedures.
 - 2. Inspections, test and related actions specified are not intended to limit the Contractor's quality control procedures that facilitate compliance with Contract Document requirements.
 - 3. Requirements for the Contractor to provide quality control services required by the Architect, Owner, or authorities having jurisdiction are not limited by provisions of this Section.

1.3 RESPONSIBILITIES

- A. Retesting: The Contractor is responsible for retesting where results of required inspections, tests or similar services prove unsatisfactory and do not indicate compliance with Contract Document requirements, regardless of whether the original test was the Contractor's responsibility.
1. Costs of retesting construction revised or replaced by the Contractor is the Contractor's responsibility, where required tests, performed on original construction, do not indicate compliance with Contract Documents.
- B. Associated Services: The Contractor shall cooperate with agencies performing required inspections, tests and similar services and provide reasonable auxiliary services as requested. Notify the agency sufficiently in advance of operations to permit assignment of personnel. Auxiliary services required include but are not limited to:
1. Providing access to the Work and furnishing incidental labor and facilities necessary to facilitate inspections and tests.
 2. Taking adequate quantities of representative samples of materials that require testing or assisting the agency in taking samples.
 3. Providing facilities for storage and curing of test samples.
 4. Providing the agency with a preliminary design mix proposed for use for materials mixes that require control by the testing agency.
 5. Security and protection of samples and test equipment at the Project site.
- C. Owner Responsibilities: The Owner will provide inspections, tests and similar quality control services specified to be performed by independent agencies and not by the Contractor, except where they are specifically indicated as the Contractor's responsibility or are provided by another identified entity. Costs for these services are not included in the Contract Sum.
1. The Owner will employ and pay for the services of an independent agency, testing laboratory or other qualified firm to perform services which are the owner's responsibility.
 2. The Contractor agrees to engage and pay for the quality control services specified as the Contractor's responsibility, including retesting, from the independent agency engaged by the Owner.
- D. Duties of the Testing Agency and Special Inspector: The independent testing Agency and the Special Inspector, engaged to perform inspections, sampling and testing of materials and construction specified in individual Specification Sections, shall cooperate with the Architect and Contractor in performance of their duties, and shall provide qualified personnel to perform required inspections and tests.

1. The Agency or the Special Inspector shall notify the Architect and Contractor promptly of irregularities or deficiencies observed in the Work during performance of its services.
 2. Neither the Agency nor the Special Inspector is not authorized to release, revoke, alter or enlarge requirements of the Contract Documents, or approve or accept any portion of the Work.
 3. Neither the Agency nor the Special Inspector shall not perform any duties of the Contractor.
- E. Coordination: The Contractor and each Agency engaged to perform inspections, tests and similar services shall coordinate the sequence of activities to accommodate required services with a minimum of delay. In addition, the Contractor and each agency shall coordinate activities to avoid the necessity of removing and replacing construction to accommodate inspections and tests.
1. The Contractor is responsible for scheduling times for inspections, tests, taking samples and similar activities.

PART 2 - PRODUCTS (Not Applicable).

PART 3 - EXECUTION

3.1 REPAIR AND PROTECTION

- A. General: Upon completion of inspection, testing, sample-taking and similar services, repair damaged construction and restore substrates and finishes to eliminate deficiencies, including deficiencies in visual qualities of exposed finishes.
- B. Protect construction exposed by or for quality control service activities, and protect repaired construction.
- C. Repair and protection is the Contractor's responsibility, regardless of the assignment of responsibility for inspection, testing or similar services.

END OF SECTION 01400

SECTION 01500
TEMPORARY FACILITIES

PART 1 -GENERAL

1.1 RELATED DOCUMENTS

- A. Instructions to Bidders, AIA Document A201, "The General Conditions of the Contract for Construction," 15th Edition, 1997, the Supplementary General Conditions and Division 1, General Requirements, are a part of this Section and shall be binding on the Contractor and/or Subcontractor who performs this work. Note also all Addenda.

1.2 SUMMARY

- A. This Section specifies requirements for temporary services and facilities, including utilities, construction and support facilities, security and protection.
- B. Temporary utilities required include but are not limited to:
1. Telephone service.
- C. Temporary construction and support facilities required include but are not limited to:
1. Temporary enclosures.
 2. Temporary Project identification signs and bulletin boards.
 3. Waste disposal services.
 4. Construction aids and miscellaneous services and facilities.
- D. Security and protection facilities required include but are not limited to:
1. Temporary fire protection.
 2. Barricades, warning signs, lights.
 3. Enclosure fence for the site.
 4. Environmental protection.

1.3 QUALITY ASSURANCE

- A. Regulations: Comply with industry standards and applicable laws and regulations of authorities having jurisdiction, including but not limited to:
1. Building Code requirements.
 2. Health and safety regulations.
 3. Utility company regulations.
 4. Environmental protection regulations.

- B. Standards: Comply with NFPA Code 241, "Building Construction and Demolition Operations", ANSI-ALO Series standards for "Safety Requirements for Construction and Demolition", and NECA Electrical Design Library "Temporary Electrical Facilities."
 - 1. Refer to "Guidelines for Bid Conditions for Temporary Job Utilities and Services", prepared jointly by AGC and ASC, for industry recommendations.
 - 2. Electrical Service: Comply with NEMA, NECA and UL standards and regulations for temporary electric service. Install service in compliance with National Electric Code (NFPA 70).
- C. Inspections: Arrange for authorities having jurisdiction to inspect and test each temporary utility before use. obtain required certifications and permits.

1.4 PROJECT CONDITIONS

- A. Temporary Utilities: Prepare a schedule indicating dates for implementation and termination of each temporary utility within 15 days of the date established for commencement of the Work. At the earliest feasible time, when acceptable to the Owner, change over from use of temporary service to use of the permanent service.
- B. Conditions of Use: Keep temporary services and facilities clean and neat in appearance. Operate in a safe and efficient manner. Take necessary fire prevention measures. Do not overload facilities, or permit them to interfere with progress. Do not allow hazardous dangerous or unsanitary conditions, or public nuisances to develop or persist on the site.

PART 2 - PRODUCTS

2.1 MATERIALS

- A. General: Provide new materials; if acceptable to the Architect, undamaged previously used materials in serviceable condition may be used. Provide materials suitable for the use intended.
- B. Lumber and Plywood: Comply with requirements in Division - 6 Section "Rough Carpentry."
 - 1. For signs and directory boards, provide exterior type, Grade B-B High Density Concrete Form Overlay Plywood conforming to PS-1, of sizes and thickness indicated.
 - 2. For fences, barriers, sidewalk bridges and similar uses, provide minimum 5/8 inch thick exterior plywood.

- C. Gypsum Wallboard: Provide gypsum wallboard complying with requirements of ASTM C 36 on interior walls of temporary partitions.
- D. Paint: Comply with requirements of Division - 9 Section "Finish Painting."
 - 1. For sign panels and applying graphics, provide exterior grade alkyd gloss enamel over exterior primer.
 - 2. For interior temporary partitions, provide two coats interior latex flat wall paint.
- E. Tarpaulins: Provide waterproof, fire-resistant, UL labeled tarpaulins with flame-spread rating of 15 or less. For temporary enclosures provide translucent nylon reinforced laminated polyethylene or polyvinyl chloride fire retardant tarpaulins.
- F. Water: Owner to provide temporary water for the purposes of construction activity. Water service will be available for Contractor's use upon approval of the Owner.
- G. Open-Mesh Fencing: Provide 11-gage, galvanized 2-inch, chain link fabric fencing 6-feet high with galvanized barbed wire top strand and galvanized steel pipe posts, 1 ½ inch I.D. for line posts and 2 ½ inch I.D. for corner posts.

2.2 EQUIPMENT

- A. General: Provide new equipment; if acceptable to the Architect, undamaged, previously used equipment in serviceable condition may be used. Provide equipment suitable for use intended.
- B. Water Hoses: Provide ¾ inch heavy-duty, abrasion-resistant, flexible rubber hose 100 ft. long, with pressure rating greater than the maximum pressure of the water distribution system; provide adjustable shut-off nozzles at hose discharge.
- C. Electrical Outlets: Provide properly configured NEMA polarized outlets to prevent insertion of 110-120 volt plugs into higher voltage outlets. Provide receptacle outlets equipped with ground-fault circuit interrupters, reset button and pilot light, for connection of power tools and equipment.
- D. Electrical Power Cords: Provide grounded extension cords; use "hard-service" cords where exposed to abrasion and traffic. Provide waterproof connectors to connect separate lengths of electric cords, if single lengths will not reach areas where construction activities are in progress.

- E. Lamps and Light Fixtures: Provide general service incandescent lamps of wattage required for adequate illumination. Provide guard cages or tempered glass enclosures, where exposed to breakage. Provide exterior fixtures where exposed to moisture.
- F. First Aid Supplies: Comply with governing regulations.
- G. Fire Extinguishers: Provide hand-carried, portable UL-rated, class "All fire extinguishers for temporary offices and similar spaces. In other locations provide hand-carried, portable, UL-rated, class "ABC" dry chemical extinguishers, or a combination of extinguishers of NFPA recommended classes for the exposures.
 - 1. Comply with NFPA 10 and 241 for classification, extinguishing agent and size required by location and class of fire exposure.

PART 3 - EXECUTION

3.1 INSTALLATION

- A. Use qualified personnel for installation of temporary facilities. Locate facilities where they will serve the Project adequately and result in minimum interference with performance of the Work. Relocate and modify facilities as required, at no additional cost to the Owner.
- B. Provide each facility ready for use when needed to avoid delay. Maintain and modify as required. Do not remove until facilities are no longer needed, or are replaced by authorized use of completed permanent facilities.

3.2 TEMPORARY UTILITY INSTALLATION

- A. General: Where required, engage the appropriate local utility company to install temporary service or connect to existing service. Where the company provides only part of the service, provide the remainder with matching, compatible materials and equipment; comply with the company's recommendations.
 - 1. Arrange with the company and existing users for a time when service can be interrupted, where necessary, to make connections for temporary services.
 - 2. Provide adequate capacity at each stage of construction. Prior to temporary utility availability, provide trucked-in services.

- B. Water Service: Owner to provide water service for the purposes of construction activity. **The Owner shall be responsible for all costs associated with water service and distribution.**
- C. Temporary Lighting: Whenever overhead floor or roof deck has been installed, provide temporary lighting with local switching.
 - 1. Install and operate temporary lighting that will fulfill security and protection requirements, without operating the entire system, and will provide adequate illumination for construction operations and traffic conditions.
- E. Temporary Telephones: Contractor to provide all telephones required for Contractor's use during the extent of construction and pay all costs for installation, use, and removal. Telephones required by separate contractor's shall be installed, removed, and paid for by that contractor.
 - 1. At Contractor's telephone, post a list of important telephone numbers.

3.3 TEMPORARY CONSTRUCTION AND SUPPORT FACILITIES INSTALLATION

- A. Locate field offices, storage sheds, sanitary facilities and other temporary construction and support facilities for easy access.
 - 1. Confine apparatus, storage materials, equipment, supplies and operations to the areas bounded by the Contract and on-site limits as shown on the drawings.
 - 2. Maintain temporary construction and support facilities until near Substantial Completion. Remove prior to Substantial Completion. Personnel remaining after Substantial Completion will be permitted to use permanent facilities, under conditions acceptable to the Owner.
- B. With the cooperation of all trades and separate Contractors involved, the Contractor may utilize the permanent heating and ventilating system when completely installed and operational, providing the following conditions are met by the Contractor at no additional cost to the Owner:
 - 1. The Contractor shall minimize interruption of heat and hot water to areas of the building being utilized by the Owner and shall take adequate precaution to prevent any damage from occurring due to lack of heat.
 - 2. The Contractor shall take all necessary precautions to prevent waste of heat due to excessive ventilation of careless operation of openings in the building.

3. The system shall be protected from freezing. Any frost damage shall be repaired at the Contractor's cost.
 4. Arrangements shall be made to monitor the system operation at night and over weekends and holidays by the Contractor.
 5. All safety controls shall be installed and operating.
 6. All equipment shall be serviced and brought back to "as new" condition to the Architect's satisfaction before acceptance by the Owner.
 7. All equipment warranties and guarantees shall be extended so that their full term is available to the Owner from the date of acceptance.
 8. All permanent HVAC systems utilized for heat shall be cleaned throughout the system, including but not limited to the ductwork, cores, and coils of equipment, etc. Replacement of filters alone does not constitute a thorough cleaning.
 9. All costs for fuel shall be the responsibility of the Contractor until Substantial Completion if permanent systems are functioning and energy efficient measures are installed.
- C. Storage and Fabrication Sheds: Install storage and fabrication sheds, sized, furnished and equipped to accommodate materials and equipment involved, including temporary utility service. Sheds may be open shelters or fully enclosed spaces on the site.
- H. Drinking Water Facilities: Provide containerized tap-dispenser bottled-water type drinking water units, including paper supply.
1. Where power is accessible, provide electric water coolers to maintain dispensed water temperature at 45 to 55 deg F (7 to 13 deg C).
- I. Temporary Enclosures: Provide temporary enclosure for protection of construction in progress and completed, from exposure, foul weather, other construction operations and similar activities.
1. Where heat is needed and the permanent building enclosure is not complete, provide temporary enclosures where there is no other provision for containment of heat. Coordinate enclosure with ventilating and material drying or curing requirements to avoid dangerous conditions and effects.
 2. Install tarpaulins securely, with incombustible wood framing and other materials. Close openings of 25 square feet or less with plywood or similar materials.
 3. Close openings through floor or roof decks and horizontal surfaces with load-bearing wood-framed construction.
 4. Where temporary wood or plywood enclosure exceeds 100 square feet in area, use UL-labeled fire-retardant treated material for framing and main sheathing.

J. Protection:

1. Protect the building at all times from damages from rain water, spring water, ground water, backing up of drains and sewers and all other water. Provide all pumps, equipment and enclosures to insure this protection.
2. Remove all snow and ice as may be required for proper protection and prosecution of the work.
3. Provide all shoring, bracing and sheeting as required for safety and for proper execution of work.
4. Protect all work from damage during cold weather. if low temperatures make it impossible to continue operations safely in spite of cold weather precautions, cease work and so notify Architect. Repair and/or replacement of all work damaged from frost, freezing or any elements of the weather are the responsibility of the Contractor.
5. Protect the building and the site from damage, loss or liability due to theft or vandalism when the work is not in progress at night, weekends, or holidays.
6. Exercise precaution for the protection of persons and property at all times. Observe the provisions of applicable laws and construction codes. Take additional safety and health measures, or cause such measures to be taken as reasonably necessary. Maintain guards on machinery, equipment and other hazards as set forth in the safety provisions of the Manual of Accident Prevention in Construction, published by the Associated Contractors of America, to the extent that such provisions are not in contravention of applicable laws.
7. Protect and preserve in operating conditions all utilities traversing the work area. Repair all damages to any utility due to work performed under this Contract, to the satisfaction of the Architect at no additional cost to the Owner.

K. Temporary Lifts and Hoists: Provide facilities for hoisting materials, rubbish, and employees. Truck cranes and similar devices used for hoisting materials are considered "tools and equipment" and not temporary facilities.

L. Project Identification and Temporary Signs: Contractor to provide project identification and other signs of the size indicated; install signs where indicated to inform the public and persons seeking entrance to the Project. Support on posts or framing of preservative treated wood. Do not permit installation of unauthorized signs. Wording and layout to be provided by Architect.

1. Project Identification Sign: Erect a 4 feet x 8 feet x $\frac{3}{4}$ inches plywood sign. Frame with 2 x 4 center cross bracing, and two 4 x 4 x 12 feet long posts in 12 inch diameter by 4 feet deep concrete piers. Mount sign to framing with four $\frac{3}{8}$ inch diameter lug bolts and washers on each side of the sign.
 2. Engage an experienced sign painter to apply graphics. Apply three coats to the sign face, and one coat to the sides and rear. Architect to provide project sign layout and lettering.
 3. Temporary Signs: Prepare signs to provide directional information to construction personnel and visitors.
- M. Collection and Disposal of Waste: Collect waste from construction areas and elsewhere daily. Comply with requirements of NFPA 241 for removal of combustible waste material and debris. Enforce requirements strictly. Do not hold materials more than 7 days during normal weather or 3 days when the temperature is expected to rise above 80 deg F (27 deg C). Handle hazardous, dangerous, or unsanitary waste materials separately from other waste by containerizing properly. Dispose of material in a lawful manner. **The Contractor shall furnish and maintain dumpster service on-site for the removal of all waste material and debris. It is the responsibility of each contractor utilized for the completion of this project to remove all associated waste material and debris from the job site on a daily basis and place into appropriate waste receptacle as directed by the Contractor.**

3.4 SECURITY AND PROTECTION FACILITIES INSTALLATION

- A. Except for use of permanent fire protection as soon as available, do not change over from use of temporary security and protection facilities to permanent facilities until Substantial Completion, or longer as requested by the Architect.
- B. Temporary Fire Protection: Until fire protection needs are supplied by permanent facilities, install and maintain temporary fire protection facilities of the types needed to protect against reasonably predictable and controllable fire losses. Comply with NFPA 10 "Standard for Portable Fire Extinguishers," and NFPA 241 "Standard for Safeguarding Construction, Alterations and Demolition Operations."
 1. Locate fire extinguishers where convenient and effective for their intended purpose, but not less than one extinguisher on each floor.
 2. Store combustible materials in containers in fire-safe locations.
 3. Maintain unobstructed access to fire extinguishers, fire hydrants, temporary fire protection facilities, stairways and other access routes for fighting fires. Prohibit smoking in hazardous fire exposure areas.

4. Provide supervision of welding operations, combustion type temporary heating units, and similar sources of fire ignition.
 5. No gasoline may be stored in or close to the building at any time.
- C. Permanent Fire Protection: At the earliest feasible date in each area of the Project, complete installation of the permanent fire protection facility, including connected services, and place into operation and use. Instruct key personnel on use of facilities.
- D. Barricades, Warning Signs and Lights: Comply with standards and code requirements for erection of structurally adequate barricades. Paint with appropriate colors, graphics and warning signs to inform personnel and the public of the hazard being protected against. Where appropriate and needed provide lighting, including flashing red or amber lights.
- E. Security Enclosure and Lockup: Install substantial temporary enclosure of partially completed areas of construction. Provide locking entrances to prevent unauthorized entrance, vandalism, theft and similar violations of security.
1. Storage: Where materials and equipment must be stored, and are of value or attractive for theft, provide a secure lockup. Enforce discipline in connection with the installation and release of material to minimize the opportunity for theft and vandalism.
- F. Environmental Protection: Provide protection, operate temporary facilities and, conduct construction in ways and by methods that comply with environmental regulations, and minimize the possibility that air, waterways and subsoil might be contaminated or polluted, or that other undesirable effects might result. Avoid use of tools and equipment which produce harmful noise. Restrict use of noise making tools and equipment to hours that will minimize complaints from persons or firms near the site.

3.5 OPERATION, TERMINATION AND REMOVAL

- A. Supervision: Enforce strict discipline in use of temporary facilities. Limit availability of temporary facilities to essential and intended uses to minimize waste and abuse.
- B. Maintenance: Maintain facilities in good operating condition until removal. Protect from damage by freezing temperatures and similar elements.
1. Maintain operation of temporary enclosures, heating, cooling, humidity control, ventilation and similar facilities on a 24-hour day basis where required to achieve indicated results and to avoid possibility of damage.

2. Protection: Prevent water filled piping from freezing. Maintain markers for underground lines. Protect from damage during excavation operations.
- C. Termination and Removal: Unless the Architect requests that it be maintained longer, the contractor responsible for its installation shall remove each temporary facility when the need has ended, or when replaced by authorized use of a permanent facility, or no later than Substantial Completion. Complete or, if necessary, restore permanent construction that may have been delayed because of interference with the temporary facility. Repair damaged Work, clean exposed surfaces and replace construction that cannot be satisfactorily repaired.
1. Materials and facilities that constitute temporary facilities are property of the Contractor. The Owner reserves the right to take possession of Project identification signs.
 2. Remove temporary paving that is not intended for or acceptable for integration into permanent paving. Where the area is intended for landscape development, remove soil and aggregate fill that does not comply with requirements for fill or subsoil in the area. Remove materials contaminated with road oil, asphalt and other petrochemical compounds, and other substances which might impair growth of plant materials or lawns. Repair or replace existing and new street paving, curbs and sidewalks and grassed areas at the temporary entrances, as required by the governing authority.
 3. At Substantial Completion, clean and renovate existing and new permanent facilities that have been used during the construction period, including but not limited to:
 - a. Replace air filters and clean inside of ductwork and housings (new construction areas only).
 - b. Replace significantly worn parts and parts that have been subject to unusual operating conditions.
 - c. Replace lamps that are burned out or noticeably dimmed by substantial hours of use.

END OF SECTION 01500

SECTION 01600
REFERENCE STANDARDS, DEFINITIONS, MATERIALS AND EQUIPMENT

PART 1 -GENERAL

1.1 RELATED DOCUMENTS

- A. Instructions to Bidders, AIA Document A201, "The General Conditions of the Contract for Construction," 15th Edition, 1997, the Supplementary General Conditions and Division 1, General Requirements, are a part of this Section and shall be binding on the Contractor and/or Subcontractor who performs this work. Note also all Addenda.

1.2 SUMMARY

- A. This Section specifies applicability of industry standards to products specified, administrative and procedural requirements governing the Contractor's selection of products for use in the Project.
- B. Submittals and administrative procedures for handling requests for substitutions made after award of the Contract are included under Section 01300, "Submittals and Product Substitutions."

1.3 DEFINITIONS

- A. General: Basic Contract definitions are included in the Conditions of the Contract.
- B. Indicated: The term indicated refers to graphic representations, notes, or schedules on the Drawings, or other Paragraphs or Schedules in the Specifications, and similar requirements in the Contract Documents. Terms such as shown, noted, scheduled, and specified are used to help the reader locate the reference. There is no limitation on location.
- C. Directed: Terms such as directed, requested, authorized, selected, approved, required, and permitted mean directed by the Architect, requested by the Architect, and similar phrases.
- D. Approved: The term approved, when used in conjunction with the Architect's action on the Contractor's submittals, applications, and requests, is limited to the Architect's duties and responsibilities as stated in the Conditions of the Contract.
- E. Regulations: The term regulations includes laws, ordinances, statutes, and lawful orders issued by authorities having jurisdiction, as well as rules, conventions, and agreements within the construction industry that control performance of the Work.

- F. Furnish: The term furnish means supply and deliver to the Project site, ready for unloading, unpacking, assembly, installation, and similar operations.
- G. Install: The term install describes operations at the Project site including the actual unloading, unpacking, assembly, erection, placing, anchoring, applying, working to dimension, finishing, curing, protecting, cleaning, and similar operations.
- H. Provide: The term provide means to furnish and install, complete and ready for the intended use.
- I. Installer: An Installer is the Contractor or another entity engaged by the Contractor, either as an employee, subcontractor, or contractor of lower tier, to perform a particular construction activity, including installation, erection, application, and similar operations. Installers are required to be experienced in the operations they are engaged to perform.
 - 1. The term experienced, when used with the term Installer, means having a minimum of five previous projects similar in size and scope to this Project, being familiar with the special requirements indicated, and having complied with requirements of the authority having jurisdiction.
 - 2. Trades: Using terms such as carpentry is not intended to imply that certain construction activities must be performed by accredited or unionized individuals of a corresponding generic name, such as carpenter. It also does not imply that requirements specified apply exclusively to tradespersons of the corresponding generic name.
 - 3. Assigning Specialists: Certain Sections of the Specifications require that specific construction activities shall be performed by specialists who are recognized experts in those operations. The specialists must be engaged for those activities, and their assignments are requirements over which the Contractor has no choice or option. However, the ultimate responsibility for fulfilling Contract requirements remains with the Contractor.
 - a. This requirement shall not be interpreted to conflict with enforcing building codes and similar regulations governing the Work. It is also not intended to interfere with local trade union jurisdictional settlements and similar conventions.
- J. Project site is the space available to the Contractor for performing construction activities either exclusively or in conjunction with others performing other work as part of the Project. The extent of the Project site

is shown on the Drawings and may or may not be identical with the description of the land on which the Project is to be built.

- K. Testing Agencies: A testing agency is an independent entity engaged to perform specific inspections or tests, either at the Project site or elsewhere, and to report on and, if required, to interpret results of those inspections or tests.
- L. Definitions used in this Article are not intended to change the meaning of other terms used in the Contract Documents, such as “specialties,” “systems,” “structure,” “finishes,” “accessories,” and similar terms. Such terms such are self-explanatory and have well recognized meanings in the construction industry.
 - 1. “Products” are items purchased for incorporation in the Work, whether purchased for the Project or taken from previously purchased stock. The term “product” includes the terms “material,” “equipment,” “system,” and terms of similar intent.
 - a. “Named Products” are items identified by manufacturer’s product name, including make or model designation, indicated in the manufacturer’s published product literature, that is current as the date of the Contract Documents.
 - 2. “Materials” are products that are substantially shaped, cut, worked, mixed, finished, refined or otherwise fabricated, processed, or installed to form a part of the Work.
 - 3. “Equipment” is a product with operational parts, whether motorized or manually operated, that requires service connections such as wiring or piping.

1.4 SPECIFICATION FORMAT AND CONTENT EXPLANATION

- A. These Specifications with the accompanying Drawings are intended to describe and illustrate all material, labor, and equipment necessary to complete construction for the Kitchen and Served Renovation Doolittle Elementary School, Cheshire, CT
- B. Specification Format: These Specifications are organized into Divisions and Sections based on the Construction Specifications Institute’s 16 Division format and MASTERFORMAT numbering system.
- C. Specification Content: This Specification uses certain conventions regarding the style of language and the intended meaning of certain terms, words, and phrases when used in particular situations or circumstances. These conventions are explained as follows:

1. Abbreviated Language: Language used in Specifications and other Contract Documents is abbreviated. words and meanings shall be interpreted as appropriate. Words that are implied, but not stated, shall be interpolated as the sense requires. Singular words will be interpreted as plural and plural words interpreted as singular where applicable as the context of the Contract Documents indicates.
 2. Imperative and streamlined language is used generally in the Specifications. Requirements expressed in the imperative mood are to be performed by the Contractor. At certain locations in the Text, subjective language is used for clarity to describe responsibilities that must be fulfilled indirectly by the Contractor, or by others when so noted.
 - a. The words “shall be” are implied wherever a colon (:) is used within a sentence or phrase.
- D. In general, the Specifications will describe the “quality” of the work and the Drawings, the “extent” of the work. The Drawings and Specifications are cooperative and supplementary, however, and each item of the work is not necessarily mentioned in both the Drawings and the Specifications. All work necessary to complete the project, so described, is to be included in this Contract.
- E. In case of disagreement between Drawings and Specifications, or within either document itself, the better quality or greater quantity of work for decision and/or adjustment. Any work done by the Contractor without consulting the Architect, when the same requires a decision, shall be done at the Contractor’s risk.
- F. Omissions or Errors: If any omissions or errors are noted or instructions at variance with the obvious intent of the documents, it is the responsibility of the Contractor to call them to the Architect’s attention before signing the Contract.

1.5 SUBMITTALS

- A. Comply with requirements contained in Section 01300, “Submittals and Product Substitutions”.

1.6 QUALITY ASSURANCE

- A. Source Limitations: To the fullest extent possible, provide products of the same kind, from a single source.

- B. Compatibility of Options: When the Contractor is given the option of selecting between two or more products for use on the Project, the product selected shall be compatible with products previously selected, even if previously selected products were also options.
- C. Responsibility to furnish material: Listing or mention of materials is sufficient indication to make it the Contractor's responsibility to furnish said materials in accordance with the grades or standards indicated, free from defects impairing strength, durability or appearance, and in sufficient quantity for the proper and complete execution of the work, unless specifically stated otherwise.
- D. Responsibility for or methods: The listing or mention of any method of installation, erection, fabrication or workmanship shall not operate to make the contractor an agent, but shall be for the sole purpose of setting a standard of quality for the finished work. Contractor is free to use any alternate method, provided only that, prior to the start of the work, such alternate method is approved in writing by the Architect, as resulting in quality equal to that intended by these documents. Unless an alternate method is approved, all work shall be in strict accordance with all methods of installation, erection, fabrication and workmanship listed or mentioned herein.

1.7 INDUSTRY STANDARDS

- A. Compliance: Furnish all materials and accomplish all work in accordance with the grades or standards of materials, standards of workmanship, and manufacturer's literature, as referenced in these documents.
- B. Applicability of Standards: Except where the Contract Documents include more stringent requirements, applicable construction industry standards have the same force and effect as if bound or copied directly into the Contract Documents to the extent referenced. Such standards are made a part of the Contract Documents by reference.
- C. Publication Dates: Comply with the standards in effect as of the date of the Contract Documents.
- D. Conflicting Requirements: Where compliance with two or more standards is specified and where the standards may establish different or conflicting requirements for minimum quantities or quality levels, refer requirements that are different, but apparently equal, and uncertainties to the Architect for a decision before proceeding.
 - 1. Minimum Quantity or Quality Levels: The quantity or quality level shown or specified shall be the minimum provided or performed.

The actual installation may comply exactly with the minimum quantity or quality specified, or it may exceed the minimum within reasonable limits. To comply with these requirements, indicated numeric values are minimum or maximum, as appropriate, for the context of the requirements. Refer uncertainties to the Architect for a decision before proceeding.

- E. Copies of Standards: Each entity engaged in construction on the Project is required to be familiar with industry standards applicable to its construction activity. Copies of applicable standards are not bound with the Contract Documents.
 - 1. Where copies of standards are needed to perform a required construction activity, the Contractor shall obtain copies directly from the publication source.

- F. Abbreviations and Names: Trade association names and titles of general standards are frequently abbreviated. Where such acronyms or abbreviations are used in the Specifications or other Contract Documents, they mean the recognized name of the trade association, standards-generating organization, authority having jurisdiction, or other entity applicable to the context of the text provision. Refer to the "Encyclopedia of Associations," published by Gale Research Co., available in most libraries.

1.8 PRODUCT DELIVERY, STORAGE, AND HANDLING

- A. Deliver, store and handle products in accordance with the Architect's and manufacturer's recommendations, using means and methods that will prevent damage, deterioration and loss, including theft.
 - 1. Schedule delivery to minimize long-term storage at the site and to prevent overcrowding of construction spaces.
 - 2. Coordinate delivery with installation time to ensure minimum holding time for items that are flammable, hazardous, easily damaged, or sensitive to deterioration, theft and other losses.
 - 3. Deliver products to the site in the manufacturer's original sealed container or other packaging system, complete with labels and instructions for handling, storing, unpacking, protecting and installing.
 - 4. Inspect products upon delivery to ensure compliance with the Contract Documents, and to ensure that products are undamaged and properly protected.
 - 5. Store products at the site in a manner that will facilitate inspection and measurement of quantity or counting of units.

6. Store heavy materials away from the Project structure in a manner that will not endanger the supporting construction.
7. Store products subject to damage by the elements above ground, under cover in a weathertight enclosure, with ventilation adequate to prevent condensation. Maintain temperature and humidity within range required by manufacturer's instructions.
8. Packages, materials and equipment showing evidence of damage may be rejected by the Architect.
9. Store rigid insulation board away from the building.

PART 2 - PRODUCTS

2.1 PRODUCT SELECTION

- A. General Product Requirements: Provide products that comply with the Contract Documents, that are undamaged and, unless otherwise indicated, unused at the time of installation.
 1. Provide products complete with all accessories, trim, finish, safety guards and other devices and details needed for a complete installation and for the intended use and effect.
 2. Standard Products: Where available, provide standard products of types that have been produced and used successfully in similar situations on other projects.
- B. Product Selection Procedures: Product selection is governed by the Contract Documents and governing regulations, not by previous Project experience. Procedures governing product selection include the following:
 1. Proprietary Specification Requirements: Where only a single product or manufacturer is named, provide the product indicated, or equal to that described.
 2. Semi-proprietary Specification Requirements: Where three or more products or manufacturers are named, provide one of the products indicated. No substitutions will be permitted.
 - a. Where products or manufacturers are specified by name, accompanied by the term "or equal," or "or approved equal" comply with the Contract Document provisions concerning "substitutions" to obtain approval for use of an unnamed product.
 3. Descriptive Specification Requirements: Where Specifications describe a product or assembly, listing exact characteristics required, with or without use of a brand or trade name, provide a

- product or assembly that provides the characteristics and otherwise complies with Contract requirements.
4. Performance Specification Requirements: Where Specifications require compliance with performance requirements, provide products that comply with these requirements, and are recommended by the manufacturer for the application indicated. General overall performance of a product is implied where the product is specified for a specific application.
 - a. Manufacturer's recommendations may be contained in published product literature, or by the manufacturer's certification of performance.
 5. Compliance with Standards, Codes and Regulations: Where the Specifications only require compliance with an imposed code, standard or regulation, select a product that complies with the standards, codes or regulations specified.
 6. Visual Matching: Where Specifications require matching an established Sample, the Architect's decision will be final on whether a proposed product matches satisfactorily.
 - a. Where no product available within the specified category matches satisfactorily and also complies with other specified requirements, comply with provisions of the Contract Documents concerning "substitutions" for selection of a matching product in another product category, or for noncompliance with specified requirements.
 7. Visual Selection: Where specified product requirements include the phrase " as selected from manufacturer's standard colors, patterns, textures " or a similar phrase, select a product and manufacturer that complies with other specified requirements. The Architect will select the color, pattern and texture from the product line selected.

PART 3 - EXECUTION

3.1 INSTALLATION OF PRODUCTS:

- A. Comply with manufacturer's instructions and recommendations for installation of products in the applications indicated. Anchor each product securely in place, accurately located and aligned with other Work.

1. Clean exposed surfaces and protect as necessary to ensure freedom from damage and deterioration at time of Substantial Completion.

END OF SECTION 01600

SECTION 01620
STORAGE AND PROTECTION

PART 1 -GENERAL

1.1 RELATED DOCUMENTS

- A. Instructions to Bidders, AIA Document A201, "The General Conditions of the Contract for Construction," 15th Edition, 1997, the Supplementary General Conditions and Division 1, General Requirements, are a part of this Section and shall be binding on the Contractor and/or Subcontractor who performs this work. Note also all Addenda.

1.02 SCOPE OF THE WORK

- A. Furnishings disturbed by the work shall be relocated and stored within the building by the General Contractor. This equipment will be cleaned and reinstalled by the General Contractor.
- B. New furnishings and equipment purchased by the Owner shall be installed by the Owner. New furnishings and equipment purchased supplied under this project shall be installed by the Contractor.

1.03 PROCEDURE

- A. Loose materials, books and supplies shall be boxed and removed from the area of Work by the Owner prior to the arrival of the Contractor's forces.
- B. Movable furnishings shall be marked by the Contractor for return or relocation in accordance with a Key Plan generated by the Contractor as required. Labels shall be at least 2" x 3" in size and shall be easily removable without damage to, or residue left on, the applied surfaces.
- C. Electronic equipment including but not limited to computers (PC's), typewriters, copy machines, etc. shall be removed from the area of Work by the Owner prior to the arrival of the Contractor's forces. The Contractor shall coordinate with the Owner any other items in question.
- D. The Contractor shall properly package or otherwise protect all items moved and stored to insure their safe relocation. All such packaging and protective gear shall be provided at no additional cost to Montville Public Schools and shall be removed by the Contractor upon completion of the reinstallation phase.
- E. The Contractor shall provide a complete written inventory of all boxes, furnishings, equipment, etc. just prior to removal for storage. This inventory shall be monitored by the Owner's Representative. The same inventory will be utilized when the materials are returned for reinstallation.

- F. Boxes packed by the Owner shall be unpacked by the Owner.

1.04 STORAGE

- A. All materials removed shall be stored in a dry secure environment. Storage location is at the Contractor's option. The Contractor together with the General Contractor can utilize areas within the building to store boxes, equipment and furnishings. The Contractor can also opt for the use of on site storage trailer boxes that are dry and secure, or off site insured warehousing controlled by the Contractor. In all cases, the Contractor shall be responsible for providing safe, dry and secure storage.

1.05 CLEANING

- A. The Contractor shall be responsible for reinstalling all furnishings and equipment in a clean, dust free, ready to use and in an acceptable condition to the Owner and Architect.

END OF SECTION 01620

SECTION 01700
PROJECT CLOSEOUT

PART 1 -GENERAL

1.1 RELATED DOCUMENTS

- A. Instructions to Bidders, AIA Document A201, "The General Conditions of the Contract for Construction," 15th Edition, 1997, the Supplementary General Conditions and Division 1, General Requirements, are a part of this Section and shall be binding on the Contractor and/or Subcontractor who performs this work. Note also all Addenda.

1.2 SUMMARY

- A. This Section specifies administrative and procedural requirements for project closeout by the Contractor, including but not limited to:
1. Final inspection procedures.
 2. Project record document submittal.
 3. Operating and maintenance manual submittal.
 4. Submittal of warranties.
 5. Final cleaning.
- B. Closeout requirements for specific construction activities are included in the appropriate Sections in Divisions - 2 through - 16.

1.3 SUBSTANTIAL COMPLETION

- A. Preliminary Procedures: Before requesting inspection by the Architect for certification of Substantial Completion, complete the following. List exceptions in the request.
1. In the Application for Payment that coincides with, or first follows, the date Substantial Completion is claimed, show 100 percent completion for the portion of the Work claimed as substantially complete. Include supporting documentation for completion as indicated in these Contract Documents and a statement showing an accounting of changes to the Contract Sum.
 - a. If 100 percent completion cannot be shown, include a list of incomplete items, the value of incomplete construction, and reasons the Work is not complete.
 2. Advise the Owner of pending insurance change-over requirements.
 3. Submit specific warranties, workmanship bonds, maintenance agreements, final certifications and similar documents.
 4. Obtain and submit releases to the Architect enabling the Owner unrestricted use of the Work and access to services and utilities;

- include occupancy permits, operating certificates and similar releases.
 - 5. Submit record drawings, maintenance manuals and similar final record information to the Architect.
 - 6. Deliver tools, spare parts, extra stock, and similar items.
 - 7. Remove temporary facilities from the site, along with construction tools, mock-ups, and similar elements.
 - 8. Complete final clean up requirements, including touch-up painting. Touch-up and otherwise repair and restore marred exposed finishes.
- B. Final Inspection Procedures: Submit a request for final inspection, to the Architect. Following the Architect's final inspection, the Architect will either prepare the Certificate of Substantial Completion, or advise the Contractor of construction that must be completed or corrected before the certificate will be issued.
- 1. The Architect will repeat final inspection when requested by the Contractor and assured that the Work has been substantially completed.
 - 2. Results of the completed final inspection will form the basis of requirements for final acceptance.

1.4 FINAL ACCEPTANCE

- A. Preliminary Procedures: Before requesting final inspection for certification of final acceptance and final payment, complete the following. List exceptions in the request.
- 1. Submit the final payment request to the Architect with releases and supporting documentation not previously submitted and accepted. Include certificates of insurance for products and completed operations where required.
 - 2. Submit an updated final statement to the Architect, accounting for final additional changes to the Contract Sum.
 - 3. Submit a certified copy of the Architect's Final Inspection list of items to be completed or corrected, stating that each item has been completed or otherwise resolved for acceptance, and the list has been endorsed and dated by the Contractor.
 - 4. Submit consent of surety to final payment.
 - 5. Submit evidence of final, continuing insurance coverage complying with insurance requirements.
- B. Reinspection Procedure: The Architect will re-inspect the work upon receipt of notice from the Contractor that the Work, including Final Inspection list items from earlier inspections, has been completed, except

items whose completion has been delayed because of circumstances acceptable to the Architect.

1. Upon completion of reinspection, the Architect will prepare a certificate of final acceptance, or advise the Contractor of Work that is incomplete or of obligations that have not been fulfilled but are required for final acceptance.
2. If necessary, reinspection will be repeated.

1.5 RECORD DOCUMENT SUBMITTALS

- A. General: Do not use record documents for construction purposes; protect from deterioration and loss in a secure, fire-resistive location; provide access to record documents for the Architect's reference during normal working hours.
- B. Record Drawings: Maintain a clean, undamaged set of blue or black line white-prints of Contract Drawings and Shop Drawings. Mark the set to show the actual installation where the installation varies substantially from the Work as originally shown. Mark whichever drawing is most capable of showing conditions fully and accurately; where Shop Drawings are used, record a cross-reference at the corresponding location on the Contract Drawings. Give particular attention to concealed elements that would be difficult to measure and record at a later date.
 1. Mark record sets with red erasable pencil; use other colors to distinguish between variations in separate categories of the Work.
 2. Mark new information that is important to the Owner, but was not shown on Contract Drawings or Shop Drawings.
 3. Note related Change Order numbers where applicable.
 4. organize record drawing sheets into manageable sets, bind with durable paper cover sheets, and print suitable titles, dates and other identification on the cover of each set. Submit to the Architect.
- C. Maintenance Manuals: Organize and submit to the Architect operating and maintenance data into suitable sets of manageable size. Bind properly indexed data in individual heavy-duty 2-inch, 3-ring vinyl-covered binders, with pocket folders for folded sheet information. Mark appropriate identification on front and spine of each binder. Include the following types of information:
 1. Emergency instructions.
 2. Copies of warranties.
 3. Recommended "turn around" cycles.
 4. Inspection procedures.
 5. Shop Drawings and Product Data.

6. All Maintenance Manuals are to be submitted in duplicate.

PART 2 - PRODUCTS (Not Applicable)

PART 3 - EXECUTION

3.1 FINAL CLEANING

- A. General: General cleaning during construction is required by the General Conditions and included in Section 01500 "Temporary Facilities".
- B. Cleaning: Employ experienced workers or professional cleaners for final cleaning. Clean each surface or unit to the condition expected in a normal, commercial building cleaning and maintenance program. Comply with manufacturer's instructions.
 1. Complete the following cleaning operations before requesting inspection for Certification of Substantial Completion.
 - a. Remove labels that are not permanent labels.
 - b. Clean transparent materials. Remove glazing compound and other substances that are noticeable vision-obscuring materials. Replace chipped or broken glass and other damaged transparent materials.
 - c. Clean exposed exterior and interior hard-surfaced finishes to a dust-free condition, free of stains, films and similar foreign substances. Restore reflective surfaces to their original reflective condition. Leave concrete floors broom clean. Vacuum carpeted surfaces.
 - d. Clean the site, including landscape development areas, of rubbish, litter and other foreign substances. Sweep paved areas broom clean; remove stains, spills and other foreign deposits. Rake grounds that are neither paved nor planted, to a smooth even-textured surface.
- C. Removal of Protection: Remove temporary protection and facilities installed for protection of the work during construction.
- D. Compliance: Comply with regulations of authorities having jurisdiction and safety standards for cleaning. Do not burn waste materials. Do not bury debris or excess materials on the Owner's property. Do not discharge volatile, harmful or dangerous materials into drainage systems. Remove waste materials from the site and dispose of in a lawful manner.

1. Where extra materials of value remaining after completion of associated Work have become the Owner's property, arrange for disposition of these materials as directed.
- E. If the Contractor fails to demonstrate a commitment to accomplish the required cleaning in an orderly, timely fashion, the Owner reserves the right to employ a professional cleaning service, and to deduct any costs thereof from the Contract Amount.

END OF SECTION 01700

SECTION 01710
CLEANING OF NEW AND EXISTING SPACES

PART 1 -GENERAL

1.1 RELATED DOCUMENTS

- A. Instructions to Bidders, AIA Document A201, "The General Conditions of the Contract for Construction," 15th Edition, 1997, the Supplementary General Conditions and Division 1, General Requirements, are a part of this Section and shall be binding on the Contractor and/or Subcontractor who performs this work. Note also all Addenda.

1.02 SCOPE OF THE WORK

- A. Furnish all labor, materials and other services required to give the new and existing spaces a thorough cleaning in preparation for occupancy or before the Owner takes re-occupancy after each phase. Carefully note that this specification applies to all sections of the building either renovated or completed by the contractor prior to re-occupancy by the Owner at the completion of the project. The use of a professional cleaning service is strongly advocated.
- B. Cleaning shall consist of, but is not limited to, the items below:
1. All accumulated rubbish shall be removed from the building and points immediately adjacent thereto and removed from the site.
 2. Give the entire project a thorough cleaning at the completion of all other work but before the glass is cleaned.
 3. Clean all glass, including windows, remove putty, stains and paint, wash and polish same. Care shall be taken not to scratch glass. Cleaning of glass shall be done after completion of all other work.
 4. Clean all paint, decorated and stained work; remove all marks, stains, fingerprints and other soil or dirt from all painted and stained work.
 5. Remove all temporary protections. Clean and polish all affected floors at completion.
 6. Clean and polish all painted woodwork at completion.
 7. Clean and polish all hardware for all trades; this shall include removal of all stains, dust, dirt, paint, etc., upon completion.
 8. Remove all spots, soil and paint from all tile work; wash same upon completion.
 9. Clean all fixtures and equipment, remove all stains, paint, dirt and dust.
 10. Thoroughly wash and clean all dirt and stains on all exterior vertical and horizontal surfaces affected by this contract.

11. Leave the final renovated area clean. Should the Contractor fail to demonstrate a commitment to accomplish the required cleaning in adequate time for re-occupancy, the Owner reserves the right to employ a professional cleaning service and to deduct the cost thereof from the Contract for Construction.

END OF SECTION 01710

SECTION 02070
SELECTIVE DEMOLITION

PART 1 -GENERAL

1.1 RELATED DOCUMENTS

- A. Instructions to Bidders, AIA Document A201, "The General Conditions of the Contract for Construction," 15th Edition, 1997, the Supplementary General Conditions and Division 1, General Requirements, are a part of this Section and shall be binding on the Contractor and/or Subcontractor who performs this work. Note also all Addenda.

1.2 SUMMARY

- A. This Section requires the selective removal and subsequent off-site disposal of the following:
1. Portions of existing building elements indicated on drawings and as required to accommodate new construction.
 2. The removal and disposal of portable classroom structures
- B. Related Work Specified Elsewhere, including but not limited to:
1. Division 15 - Mechanical
 2. Division 16 - Electrical

1.3 SUBMITTALS

- A. General: Submit the following in accordance with Conditions of Contract and Division 1 Specification Sections.

1.4 JOB CONDITIONS

- A. Condition of Structures: Owner assumes no responsibility for actual condition of items or structures to be demolished. Conditions existing at time of inspection for bidding purposes will be maintained by Owner insofar as practicable. However, minor variations within structure may occur by Owner's removal and salvage operations prior to start of selective demolition work.
- B. Partial Demolition and Removal: Items indicated to be removed but of salvageable value to Contractor may be removed from structure as work progresses. **Owner has right of first refusal for all salvaged items removed from the existing building and not required for the completed renovation.** Owner to designate on-site location for storage of salvaged items for their use. Owner to transport salvaged items for

their retention to an off-site location as required. Transport salvaged items from site as they are removed.

1. Storage or sale of removed items on site will not be permitted.
- C. Protections: Provide temporary barricades and other forms of protection to protect Owner's personnel and general public from injury due to selective demolition work.
1. Provide interior and exterior shoring, bracing, or support to prevent movement, settlement, or collapse of structure or element to be demolished and adjacent facilities or work to remain.
 2. Protect from damage existing finish work that is to remain in place and becomes exposed during demolition operations.
 3. Protect floors with suitable coverings when necessary.
 4. Provide temporary weather protection during interval between demolition and removal of existing construction on exterior surfaces and installation of new construction to ensure that no water leakage or damage occurs to structure or interior areas of existing building.
 5. Remove protections at completion of work.
- D. Damages: Promptly repair damages caused to adjacent surfaces by demolition work.
- E. Traffic: Conduct selective demolition operations and debris removal to ensure minimum interference with roads, streets, walks, and other adjacent occupied or used facilities.
1. Do not close, block, or otherwise obstruct streets, walks, or other occupied or used facilities without written permission from authorities having jurisdiction. Provide alternate routes around closed or obstructed traffic ways if required by governing regulations.
- F. Utility Services: Maintain existing utilities indicated to remain in service and protect them against damage during demolition operations.
1. Do not interrupt utilities serving occupied or used facilities, except when authorized in writing by authorities having jurisdiction. Provide temporary services during interruptions to existing utilities, as acceptable to governing authorities.
- G. Environmental Controls: Use water sprinkling, temporary enclosures, and other methods to limit dust and dirt migration. Comply with governing regulations pertaining to environmental protection.

1. Do not use water when it may create hazardous or objectionable conditions such as ice, flooding, and pollution.

PART 2 PRODUCTS (Not Applicable)

PART 3 EXECUTION

3.1 PREPARATION

- A. General: Provide interior and exterior shoring, bracing, or support to prevent movement, settlement, or collapse of areas to be demolished and adjacent facilities to remain.
 1. Cease operations and notify Owner's Representative immediately if safety of structure appears to be endangered. Take precautions to support structure until determination is made for continuing operations.
 2. Cover and protect furniture, equipment, and fixtures from soilage or damage when demolition work is performed in areas where such items have not been removed.
 3. Locate, identify, stub off, and disconnect utility services that are not indicated to remain.

3.2 DEMOLITION

- A. General: Perform selective demolition work in a systematic manner. Use such methods as required to complete work indicated on Drawings in accordance with demolition schedule and governing regulations.
 1. Provide services for effective air and water pollution controls as required by local authorities having jurisdiction.
 3. For interior concrete floor slabs, use removal methods that will not crack or structurally disturb adjacent slabs or partitions. Use power saw where possible.
- B. If unanticipated mechanical, electrical, or structural elements that conflict with intended function or design are encountered, investigate and measure both nature and extent of the conflict. Submit report to Owner's Representative in written, accurate detail. Pending receipt of directive from Owner's Representative, rearrange selective demolition schedule as necessary to continue overall job progress without undue delay.

3.3 DISPOSAL OF DEMOLISHED MATERIALS

- A. Remove from building site debris, rubbish, and other materials resulting from demolition operations. Transport and legally dispose off site.

1. Burning of removed materials is not permitted on project site.

3.4 CLEANUP AND REPAIR

- A. General: Upon completion of demolition work, remove tools, equipment, and demolished materials from site. Remove protections and leave interior areas broom clean.
 1. Repair demolition performed in excess of that required. Return elements of construction and surfaces to remain to condition existing prior to start operations. Repair adjacent construction or surfaces soiled or damaged by selective demolition work.

END OF SECTION 02070

SECTION 04200
UNIT MASONRY

PART 1 - GENERAL

1.1 RELATED DOCUMENTS

- A. Instructions to Bidders, AIA Document A201/CMA, "General Conditions of the Contract for Construction," 1992 Construction Manager-Advisor Edition, the Supplementary General Conditions and Division 1, General Requirements, are a part of this Section and shall be binding on the Contractor and/or Subcontractor who performs this work. Note also all Addenda.

1.2 SUMMARY

- A. This Section includes the following:
1. Concrete unit masonry (cmu).
 2. Mortar and Grout.
 3. Reinforcing steel and joint reinforcement.
 4. Ties, anchors, flashing and lintels related to masonry construction.
- B. Products installed but not furnished under this Section include the following:
1. Steel lintels in unit masonry are specified in Section 05500 "Metal Fabrications."
 2. Wood nailers and blocking built into unit masonry are specified in Section 06105 "Miscellaneous Carpentry."

1.3 SYSTEM PERFORMANCE REQUIREMENTS

- A. Provide unit masonry that develops the following installed compressive strengths (f'm):
1. For concrete unit masonry: As follows:
 - a. f'm = 1500 psi.

1.4 SUBMITTALS

- A. General: Submit the following in accordance with Conditions of Contract and Division 1 Specification Sections.

- B. Product data for each different masonry unit, accessory, and other manufactured product indicated.
- C. Samples for verification purposes of the following:
 - 1. Full-size units for each different exposed masonry unit required showing full range of exposed color, texture, and dimensions to be expected in completed construction.
 - 2. Colored masonry mortar samples for each color required showing the full range of colors expected in the finished construction. Label samples to indicate type and amount of colorant used.
 - 3. Accessories embedded in the masonry.
- D. Material certificates for the following signed by manufacturer and Contractor certifying that each material complies with requirements.
 - 1. Each different cement product required for mortar and grout including name of manufacturer, brand, type, and weight slips at time of delivery.
 - 2. Each material and grade indicated for reinforcing bars.
 - 3. Each type and size of joint reinforcement.
 - 4. Each type and size of anchors, ties, and metal accessories.
- E. Material test reports from a qualified independent testing laboratory employed and paid by Contractor indicating and interpreting test results relative to compliance of the following proposed masonry materials with requirements indicated:
 - 1. Mortar complying with property requirements of ASTM C 270.
 - 2. Grout mixes. Include description of type and proportions of grout ingredients.
 - 3. Masonry units.
- F. Cold-weather construction procedures evidencing compliance with requirements specified in referenced unit masonry standard.
- G. Hot-weather construction procedures evidencing compliance with requirements specified in referenced unit masonry standard.
- H. Results from tests and inspections performed by Owner's representatives will be reported promptly and in writing to Architect and Contractor.

1.5 QUALITY ASSURANCE

- A. Unit Masonry Standard: Comply with ACI 530.1/ASCE 6 "Specifications for Masonry Structures," except as otherwise indicated.
 - 1. Revise ACI 530.1/ASCE 6 to exclude Sections 1.4 and 1.7; Parts 2.1.2, 3.1.2, and 4.1.2; and Articles 1.5.1.2, 1.5.1.3, 2.1.1.1, 2.1.1.2, and 2.3.3.9 and to modify Article 2.1.1.4 by deleting requirement for installing vent pipes and conduits built into masonry.
- B. Comply with ACI 530/ASCE5 "Building Code Requirements for Masonry Structures, Section 9.5 Lateral Support for bracing requirements of partitions.
- C. Fire Performance Characteristics: Where indicated, provide materials and construction identical to those of assemblies whose fire resistance has been determined per ASTM E 119 by a testing and inspecting organization, by equivalent concrete masonry thickness, or by another means, as acceptable to authorities having jurisdiction.
- D. Single-Source Responsibility for Masonry Units: Obtain exposed masonry units of uniform texture and color, or a uniform blend within the ranges accepted for these characteristics, from one manufacturer for each different product required for each continuous surface or visually related surfaces.
- E. Single-Source Responsibility for Mortar Materials: Obtain mortar ingredients of uniform quality, including color for exposed masonry, from one manufacturer for each cementitious component and from one source and producer for each aggregate.

1.6 DELIVERY, STORAGE, AND HANDLING

- A. Deliver masonry materials to project in undamaged condition.
- B. Store and handle masonry units off the ground, under cover, and in a dry location to prevent their deterioration or damage due to moisture, temperature changes, contaminants, corrosion, and other causes. If units become wet, do not place until units are in an air-dried condition.
- C. Store cementitious materials off the ground, under cover and in dry location.
- D. Store aggregates where grading and other required characteristics can be maintained and contamination avoided.
- E. Store masonry accessories including metal items to prevent corrosion and accumulation of dirt and oil.

1.7 PROJECT CONDITIONS

- A. Protection of Masonry: During erection, cover tops of walls, projections, and sills with waterproof sheeting at end of each day's work. Cover partially completed masonry when construction is not in progress.
 - 1. Extend cover a minimum of 24 inches down both sides and hold cover securely in place.
 - 2. Where one wythe of multiwythe masonry walls is completed in advance of other wythes, secure cover a minimum of 24 inches down face next to unconstructed wythe and hold cover in place.
- B. Stain Prevention: Prevent grout, mortar, and soil from staining the face of masonry to be left exposed or painted. Remove immediately any grout, mortar, and soil that come in contact with such masonry.
 - 1. Protect base of walls from rain-splashed mud and mortar splatter by means of coverings spread on ground and over wall surface.
 - 2. Protect sills, ledges, and projections from mortar droppings.
 - 3. Protect surfaces of window and door frames, as well as similar products with painted and integral finishes from mortar droppings.
- C. Cold-weather Construction: Comply with referenced unit masonry standard for cold-weather construction and the following:
 - 1. Do not lay masonry units that are wet or frozen.
 - 2. Remove masonry damaged by freezing conditions.
- D. Hot-Weather Construction: Comply with referenced unit masonry standard.

PART 2 - PRODUCTS

2.1 MATERIALS, GENERAL

- A. Comply with referenced unit masonry standard and other requirements specified in this Section applicable to each material indicated.

2.2 CONCRETE MASONRY UNITS

- A. General: Comply with requirements indicated below applicable to each form of concrete masonry unit required.

1. Size: Provide concrete masonry units complying with requirements indicated below for size that are manufactured to specified face dimensions within tolerances specified in the applicable referenced ASTM specification for concrete masonry units.
 - a. Concrete Masonry Units: Manufactured to specified dimensions of 3/8 inch less than nominal widths by nominal heights by nominal lengths indicated on drawings.
 - b. Concrete Building Brick: Specified dimensions as follows:
 - 1) Standard Modular: 3-5/8 inches wide by 2-1/4 inches high by 7-5/8 inches long.
- B. Hollow and Solid Load-Bearing Concrete Masonry Units: ASTM C 90-90, C145, and Grade N and as follows:
 1. Unit Compressive Strength: Provide units with minimum average net area compressive strength indicated below:
 - a. 1900 psi.
 2. Weight Classification: Lightweight.
 3. Aggregates: Lightweight, expanded shale, clay or slate produced by the rotary kiln method complying with ASTM C-331, and shall be graded (#4-0 Gradation) to assume constant texture. The blending of screenings or any other deleterious substance which will impair the fire rating or insulation values is prohibited.
 4. Units made with pumice or burn-off aggregates will not be accepted.
- C. Fire Rated Concrete Masonry Units: ASTM E 119, UL 618 and the American Insurance Association Specifications for the equivalent thickness for 2 hours or better, and meeting the requirements for concrete masonry units above.

2.3 MORTAR AND GROUT MATERIALS

- A. Portland Cement: ASTM C 150, Type I or II, except Type III may be used for cold-weather construction. Provide natural color or white cement as required to produce required mortar color.
- B. Masonry Cement: ASTM C 91.

1. For colored pigmented mortars use premixed colored masonry cements of formulation required to produce color indicated, or if not indicated, as selected from manufacturer's standard formulations.
- C. Products: Subject to compliance with requirements, provide one of the following:
 1. Colored Masonry Cement:
 - a. "Colorbond Custom Color Masonry Cement," Centurion
 - b. "Atlas Custom Color Masonry Cement," Lehigh Portland Cement Co.
 - c. "Flamingo Color Masonry Cement," The Riverton Corporation.
 2. Varying mortar colors will be selected for each type of masonry utilized.

2.4 REINFORCING STEEL

- A. General: Provide reinforcing steel complying with requirements of referenced unit masonry standard and this article.
- B. Steel Reinforcing Bars: Material and grade as follows:
 1. Grade 60.
- C. Deformed Reinforcing Wire: ASTM A 496.

2.5 JOINT REINFORCEMENT

- A. General: Provide joint reinforcement complying with requirements of referenced unit masonry standard and this article, formed from the following:
 1. Galvanized carbon steel wire, ASTM-A153, Class B-2, hot-dipped,,1.5 oz. galvanized coating.
- B. Description: Welded-wire units prefabricated with deformed continuous side rods and plain cross rods into straight lengths of not less than 10 feet, with prefabricated corner and tee units, and complying with requirements indicated below:
 1. Wire Diameter for Side Rods: 0.1483 inch (9 gage).
 2. Wire Diameter for Cross Rods: 0.1483 inch (9 gage).

3. For single-wythe masonry provide type as follows with single pair of side rods:
 - a. Ladder design with continuous cross rods spaced not more than 16 inches o.c.
 - b. Subject to compliance with requirements, provide one of the following:
 - 1) "220 Ladder-Mesh", by Hohmann & Barnard, Inc., or equal.

2.6 TIES AND ANCHORS, GENERAL

- A. General: Provide ties and anchors specified in subsequent articles that comply with requirements for metal and size of referenced unit masonry standard and of this article.
- B. Galvanized Carbon Steel Wire: ASTM A 82, ASTM-A153, Class B-2, hot dipped, 1.5 oz. galvanized coating.
- C. Galvanized Steel Sheet: As follows:
 - a. Galvanized Steel Sheet: ASTM A 366 (commercial quality) cold-rolled carbon steel sheet, hot-dip galvanized after fabrication to comply with ASTM A 525, Class B2 (for unit lengths over 15 inches) and Class B3 (for unit lengths under 15 inches), for all sheet metal ties and anchors.

2.7 ADJUSTABLE ANCHORS FOR CONNECTING MASONRY TO CONCRETE OR METAL STUD CONSTRUCTION

- A. General: Two-piece assemblies as described below allowing vertical or horizontal differential movement between wall and framework parallel to plane of wall, but resisting tension and compression forces perpendicular to it.
 1. Performance Characteristics: Capable of withstanding a 100 lb. force in either tension or compression without deforming over, or developing play in excess of, .05 inch.
- B. Screw-Attached Masonry Veneer Anchors: Units consisting of wire tie section and metal anchor section complying with the following requirements:
 1. Wire Tie Diameter: 3/16 inch
 2. Wire Tie Shape: Double Leg Pintle.

3. Wire Tie Length: 3 inch, 4 inch or 5 inch as required to extend 1-1/2 inches, but no closer than 1-1/4 inch from the outside face of masonry, into masonry wythe of veneer.
- C. Neoprene Gaskets: Screw-attached masonry veneer anchor manufacturer's standard closed cell neoprene gaskets manufactured to fit behind anchor plate and to prevent moisture from penetrating through screw holes.
- D. Products: Subject to compliance with requirements, provide the following:
 1. Screw-Attached Masonry Veneer Anchors:
 - a. D/A 213, type .5, 1, 1.5 or 2 Extra Heavy Duty," Dur-O-Wal, Inc.
 - b. D/A 5213, Dur-O-Wal, Inc.
 2. Provide powder-actuated fasteners, with a minimum working strength value of 100 lbs., driven through holes in the masonry veneer anchors, into the concrete, or metal stud.

2.8 ADJUSTABLE ANCHORS FOR CONNECTING MASONRY TO STRUCTURAL STEEL

- A. General: Two-piece assemblies as described below allowing vertical or horizontal differential movement between wall and structural steel parallel to plane of wall, but resisting tension and compression forces perpendicular to it.
 1. Performance Characteristics: Capable of withstanding a 100 lb. force in either tension or compression without deforming over, or developing play in excess of, .05 inch.
- B. For anchorage of masonry inner wythes to the face of steel columns, and to the underside of structural steel members, furnish to the structural steel fabricator continuous channel slots formed from 16 ga. (mill) galvanized sheet steel.
 1. Provide channel slot anchors formed from 3/16 inch diameter wire.
- C. Products: Subject to compliance with requirements, provide the following:
 1. Channel Slots:
 - a. D/A 904, Dur-O-Wal, Inc.

2. Triangle Tie Slot Anchors:
 - a. D/A 918-922, Dur-O-Wal, Inc.
- D. For the anchorage of masonry to the webs of steel beams at cavity wall conditions, furnish to the structural steel fabricator channel anchor slots formed from 16 gauge brite sheet steel, 8" long.
 1. Provide channel slot anchors formed from 16 gauge corrugated brite sheet metal, 3-1/2" long.
- E. Products: Subject to compliance with requirements, provide the following:
 1. Channel Slots:
 - a. D/A 901, Dur-O-Wal, Inc.
 2. Corrugated Channel Slot Anchors:
 - a. D/A 912, Dur-O-Wal, Inc.

2.9 ANCHORS FOR CONNECTING INTERIOR MASONRY PARTITIONS TO UNDERSIDE OF METAL DECKING AND JOINT STABILIZATION

- A. For anchorage of interior masonry partitions to the underside of metal decking or other structure above, and for joint stabilization assemblies at expansion, contraction or isolation joints. Spacing at 16 inches maximum centers.
- B. Products: Subject to compliance with requirements, provide the following:
 1. Joint Stabilization Anchors:
 - a. D/A 2200, Dur-O-Wal, Inc.

2.10 MISCELLANEOUS ANCHORS

- A. Provide 4 x 3 x 1/4 x 6 inch long steel clip angle anchors for laterally bracing masonry partitions to floor deck and underside of beams or girders above, arranged in pairs on each face of partition requiring bracing, spaced at 4' - 0" maximum centers.
 1. Provide these anchors in all locations where the length of a partition between lateral supports (buttresses, crosswalls, columns with ties), exceeds 36 times its thickness.

2. Provide these anchors in all partitions interrupted by control joints (except crosswalls).

2.11 MISCELLANEOUS MASONRY ACCESSORIES

- A. Nonmetallic Control Joint and Brick Expansion Joint Strips: Premolded filler strips complying with ASTM D 1056, Type 2 (closed cell) , Class A (cellular rubber and rubber-like materials with specific resistance to petroleum base oils), Grade 1 (compression-deflection range of 2-5 psi), compressible up to 35 percent, of width and thickness indicated, formulated from the following material:
 1. Neoprene.
 2. Products: Subject to compliance with requirements, provide one of the following:
 - a. "Rapid Expansion Joint, D/A 2015", Dur-O-Wal, Inc.
 - b. "NS Closed Cell Neoprene Sponge", Hohmann and Barnard, Inc.
 - c. "032 Expansion Joint", National Wire Products Ind.
- C. Bond Breaker Strips: Asphalt-saturated organic roofing felt complying with ASTM D 226, Type I (No. 15 asphalt felt).
- E. Wire Mesh Wall Ties: 2" x 2" x 16 gauge hot dipped galvanized wire for intersections of non-structural masonry walls.
 1. Products: Subject to compliance with requirements, provide one of the following:
 - a. "No. 269 Wire Mesh Wall Tie", Heckman Building Products, Inc.
- F. Mortar Net: Provide the following:
 1. High-density polyethylene in two inch thickness. Product to be 90% open weave mesh in a dovetail configuration connected by a continuous bottom strip.
 2. #MN 10-2, as manufactured by Mortar Net USA Ltd, or equal.

2.12 MORTAR AND GROUT MIXES

- A. General: Do not add admixtures including coloring pigments, air-entraining agents, accelerators, retarders, water repellent agents, antifreeze compounds, or other admixtures, unless otherwise indicated.

1. Do not use calcium chloride in mortar or grout.
- B. Mortar for Unit Masonry: Comply with ASTM C 270, Property Specification for job-mixed mortar and ASTM C 1142 for ready-mixed mortar, of types indicated below:
 1. For exterior, above-grade loadbearing and nonloadbearing walls and parapet walls, for reinforced masonry and where indicated, use type indicated below:
 - a. Type N.
 2. For interior loadbearing walls; for interior nonloadbearing partitions, and for other applications where another type is not indicated, use type indicated below:
 - a. Type N.
- C. Grout for Unit Masonry: Comply with ASTM C 476 and referenced unit masonry standard.
- D. **All mortar utilized for single wythe cmu wall construction shall contain The Dry Block Integral Water Repellant System by W.R. Grace & Co.**

PART 3 - EXECUTION

3.1 EXAMINATION

- A. Examine conditions, with Installer present, for compliance with requirements for installation tolerances and other specific conditions, and other conditions affecting performance of unit masonry.
- B. Examine rough-in and built-in construction to verify actual locations of piping connections prior to installation.
- C. Notify General Contractor and do not proceed until unsatisfactory conditions have been corrected.

3.2 INSTALLATION, GENERAL

- A. Comply with referenced unit masonry standard and other requirements indicated applicable to each type of installation included in Project.

- B. Thickness: Build masonry construction to the full thickness shown. Build single-wythe walls to the actual thickness of the masonry units, using units of nominal thickness indicated.
- C. Leave openings for equipment to be installed before completion of masonry. After installation of equipment, complete masonry to match construction immediately adjacent to the opening.
- D. Cut masonry units with motor-driven saws to provide clean, sharp, unchipped edges. Cut units as required to provide continuous pattern and to fit adjoining construction. Use full-size units without cutting where possible.

3.3 CONSTRUCTION TOLERANCES

- A. Comply with construction tolerances of referenced unit masonry standard.

3.4 LAYING MASONRY WALLS

- A. Lay out walls in advance for accurate spacing of surface bond patterns with uniform joint widths and for accurate locating of openings, movement-type joints, returns, and offsets. Avoid the use of less-than-half-size units at corners, jambs, and where possible at other locations.
- B. Lay up walls to comply with specified construction tolerances, with courses accurately spaced and coordinated with other construction.
- C. Bond Pattern for Exposed Masonry: Lay exposed masonry in the following bond pattern; do not use units with less than nominal 4-inch horizontal face dimensions at corners or jambs.
 - 1. One-half running bond with vertical joint in each course centered on units in courses above and below.
- D. Lay concealed masonry with all units in a wythe in running bond or bonded by lapping not less than 2 inches. Bond and interlock each course of each wythe at corners. Do not use units with less than nominal 4-inch horizontal face dimensions at corners or jambs.
- E. Stopping and Resuming Work: In each course, rake back $\frac{1}{2}$ -unit length for one-half running bond or $\frac{1}{3}$ -unit length for one-third running bond; do not tooth. Clean exposed surfaces of set masonry, wet clay masonry units lightly (if required), and remove loose masonry units and mortar prior to laying fresh masonry.

- F. Built-In Work: As construction progresses, build-in items specified under this and other Sections of the Fill in solidly with masonry around Specifications. built-in items.
 - 1. Fill space between hollow metal frames and masonry solidly with mortar, unless otherwise indicated.
 - 2. Fill cores in hollow concrete masonry units with grout 3 courses (24 inches) under bearing plates, beams, lintels, posts, and similar items, unless otherwise indicated.

3.5 MORTAR BEDDING AND JOINTING

- A. Lay solid brick masonry units with completely filled bed and head joint; butter ends with sufficient mortar to fill head joints and shove into place. Do not slush head joints.
- B. Lay masonry units as follows:
 - 1. With full mortar coverage on horizontal and vertical face shells.
 - 2. Bed webs in mortar in starting course on footings and in all courses of piers, columns, and pilasters, and where adjacent to cells or cavities to be filled with grout.
 - 3. For starting course on footings where cells are not grouted, spread out full mortar bed including areas under cells.
- C. Cut joints flush for masonry walls to be concealed or to be covered by other materials.
- D. Tool joints for masonry walls to be exposed in compliance with referenced masonry standard.
- E. Tool joints in block veneer as directed by the Construction Manager.

3.6 ANCHORING MASONRY TO STRUCTURAL MEMBERS

- A. Anchor masonry to structural members where masonry abuts or faces structural members to comply with the following:
 - 1. Provide an open space not less than 1 inch in width between masonry and structural member, unless otherwise indicated. Keep open space free of mortar or other rigid materials
 - 2. Anchor masonry to structural members with flexible anchors embedded in masonry joints and attached to structure.
 - 3. Space anchors as indicated, but not more than 16 inches o.c. vertically and 32 inches o.c. horizontally.

3.7 MOVEMENT JOINTS

- A. General: Install control joints in unit masonry where indicated. Build in related items as the masonry progresses. Do not form a continuous span through movement joints unless provisions are made to prevent in-plane restraint of wall or partition movement.
- B. Form control joints in concrete masonry as follows:
 - 1. Form open joint of not less than 3/8 inch and insert non metallic compressible joint filler in width equal to actual width of concrete masonry units, less 3/8 inch for installation of backer rod and sealant by Section 07920.
 - 2. Where backer rod and sealant will be installed on both sides of masonry units, install joint filler in width equal to actual width of unit masonry, less 3/4 inch.

3.8 LINTELS

- A. Install steel lintels where indicated, and wherever openings of more than 2 feet for block size units are shown. Provide minimum bearing of 5 inch at each jamb, unless otherwise indicated.
- B. Provide minimum bearing of 8 inches at each jamb, unless otherwise indicated.

3.9 FIELD QUALITY CONTROL

- A. Testing Frequency: Tests and evaluations listed in this article will be performed during construction for each 5000 sq. ft. of wall area or portion thereof.
 - 1. Mortar properties will be tested per property specification of ASTM C 270.
 - 2. Mortar composition and properties will be evaluated per ASTM C 780.
 - 3. Grout compressive strength will be sampled and tested per ASTM C 1019.
- B. Evaluation of Quality Control Tests: In absence of other indications of noncompliance with requirements, masonry will be considered satisfactory if results from construction quality control tests comply with minimum requirements indicated.

END OF SECTION 04200

SECTION 06105
MISCELLANEOUS CARPENTRY

PART 1 -GENERAL

1.1 RELATED DOCUMENTS

- A. Instructions to Bidders, AIA Document A201, "The General Conditions of the Contract for Construction," 15th Edition, 1997, the Supplementary General Conditions and Division 1, General Requirements, are a part of this Section and shall be binding on the Contractor and/or Subcontractor who performs this work. Note also all Addenda.

1.2 SUMMARY

- A. This Section includes the following:
1. Rough carpentry work not specified elsewhere and generally intended for support of other work.
 2. Wood blocking for roofing and curbs
 3. Miscellaneous blocking, grounds, nailers, and panels.
 4. Installation of door hardware and doors within frames.
 5. Installation of equipment and/or accessories not specifically identified within the specifications.
- B. Related Sections: The following Sections contain requirements that relate to this Section:
1. Section 08710 "Door Hardware" for hardware furnished for installation under this Section.
 2. Section 09255 "Gypsum Board Assemblies" for metal-stud formed partitions, gypsum sheathing and aluminum control joint covers.

1.3 SUBMITTALS

- A. General: Submit the following according to Conditions of Contract and Division 1 Specification Sections.
- B. Wood treatment data from chemical treatment manufacturer. Include chemical treatment manufacturer's instructions for handling, storing, installing, and finishing treated material.
1. Preservative Treatment: Include certification by treatment plant stating type of solution and pressure process used, net amount of preservative retained, and compliance with applicable standards.
 2. Waterborne Preservative Treatment: Include certification that moisture content of treated wood was reduced to levels specified prior to shipment to Project site.

3. Warranty: Include warranty of chemical treatment manufacturer for each type of treatment.

1.4 DELIVERY, STORAGE, AND HANDLING

A. Delivery and Storage: Keep materials under cover and dry. Protect against exposure to weather and contact with damp or wet surfaces. Stack material above ground level on uniformly spaced supports to prevent deformation.

1. For material pressure treated with waterborne chemicals, place spacers between each bundle for air circulation.

PART 2 - PRODUCTS

2.1 LUMBER, GENERAL

A. Standards: Furnish lumber manufactured to comply with PS 20 "American Softwood Lumber Standard" and with applicable grading rules of inspection agencies certified by American Lumber Standards Committee's (ALSC) Board of Review.

B. Grade Stamps: Furnish lumber with each piece factory-marked with grade stamp of inspection agency that indicates grading agency, grade, species, moisture content at time of surfacing, and mill.

1. For exposed lumber, furnish pieces marked on ends or back of each piece.

C. Sizes: Provide nominal sizes indicated, complying with PS 20 except where actual sizes are specifically noted as being required.

D. Surfacing: Dressed lumber, S4S, unless otherwise indicated.

2.2 DIMENSION LUMBER FOR CONCEALED CONDITIONS

A. Species: Same species as designated for exposed conditions.

B. Moisture Content: Same moisture content as designated for exposed conditions.

C. Grade: Same grade as designated for exposed conditions.

2.3 DIMENSION LUMBER FOR EXPOSED CONDITIONS

A. Species: Any one of the following:

1. Douglas fir.
2. Hem-fir.

B. Moisture Content: Kiln-dry, KD 15 or MC 15 (15 percent maximum moisture content).

C. Grade: No. 1 or construction grade.

2.4 BOARDS FOR CONCEALED CONDITIONS

A. Species: Same species as listed for exposed boards.

B. Moisture Content: Same moisture content as designated for exposed boards.

C. Grade: Same grade as listed for exposed boards.

2.5 BOARDS FOR EXPOSED CONDITIONS

A. Species: Any one of the following:

1. Douglas fir.
2. Hem-fir.

B. Moisture Content: Kiln-dry, KD 15 or MC 15 (15 percent maximum moisture content).

C. Grade: No. 1, 1 Common.

2.6 CONSTRUCTION PANELS

A. Standards: Comply with requirements of PS 1 Voluntary Product Standard "Construction and Industrial Plywood" for veneer plywood and APA PRP-108 "Performance Standards and Policies for Structural-Use Panels" for performance-rated panels.

1. Trademark: Furnish construction panels that are each factory-marked with APA trademark for grade specified.

B. Miscellaneous Concealed Plywood: C-C Plugged Exterior, thickness as indicated but not less than 5/8 inch nominal.

2.7 FASTENERS

- A. General: Where miscellaneous carpentry is exposed to weather, in ground contact, or in area of high relative humidity, provide fasteners with a hot-dip zinc coating per ASTM A 153 or of AISI Type 304 stainless steel.
- B. Nails, Wire, Brads and Staples: FS FF-N-105.
- C. Wood Screws: ANSI B18.6.1.
- D. Bolts: ASTM A 307, Grade A; with ASTM A 563 hex nuts and flat washers.

2.8 PRESERVATIVE WOOD TREATMENT BY PRESSURE PROCESS

- A. General: Obtain preservative-treated lumber complying with AWWA Standard C2. Mark each treated item with AWPB or SPIB Quality Mark Requirements. Coat surfaces cut after treatment to comply with AWWA M4.
- B. Above-Ground Wood Treatment: Pressure treat with waterborne preservatives to a minimum retention of 0.25 pcf.
 - 1. Kiln-dry interior dimension lumber after treatment to 15 percent maximum moisture content.
 - 2. Kiln-dry interior construction panels after treatment to 15 percent maximum moisture content.
 - 3. Treat wood items indicated and in the following circumstances:
 - a. In contact with roofing, flashing, or waterproofing.
 - b. In contact with masonry or concrete.
 - c. Within 18 inches of grade.
- C. Ground-Contact Wood Treatment: Pressure treat with waterborne preservatives to a minimum retention of 0.40 pcf.

PART 3 - EXECUTION

3.1 INSTALLATION, GENERAL

- A. Discard units of material with defects that impair quality of miscellaneous carpentry and in sizes that would require an excessive number or poor arrangement of joints.
- B. Cut and fit miscellaneous carpentry accurately. Install members plumb and true to line and level.
- C. Coat cut edges of preservative-treated wood to comply with AWWA M4.

- D. Securely fasten miscellaneous carpentry as indicated and according to applicable codes and recognized standards.
- E. Countersink nail heads on exposed carpentry work and fill holes.
- F. Use fasteners of appropriate type and length. Pre-drill members when necessary to avoid splitting wood.

3.2 WOOD GROUNDS, NAILERS, BLOCKING, AND SLEEPERS

- A. Install where shown and where required for screeding or attachment of other work. Cut and shape to required size. Coordinate location with other work involved.
- B. Attach to substrates as required to support applied loading. Countersink bolts and nuts flush with surfaces, unless otherwise indicated.
- C. Provide wood blocking for all wall mounted or recessed equipment including, but not limited to, toilet accessories, telephone cabinet, visual display boards and wall mounted hardware.

3.3 DOOR HARDWARE INSTALLATION

- A. Mount hardware units at heights indicated in following applicable publications, except as specifically indicated or required to comply with governing regulations and except as otherwise directed by Architect.
 - 1. "Recommended Locations for Builders Hardware for Standard Steel Doors and Frames" by the Door and Hardware Institute.
- B. Install each hardware item in compliance with the manufacturer's instructions and recommendations. Where cutting and fitting is required to install hardware onto or into surfaces that are later to be painted or finished in another way, coordinate removal, storage, and reinstallation or application of surface protection with finishing work specified in the Division 9 Sections. Do not install surface-mounted items until finishes have been completed on the substrates involved.
- C. Set units level, plumb, and true to line and location. Adjust and reinforce the attachment substrate as necessary for proper installation and operation.
- D. Drill and countersink units that are not factory prepared for anchorage fasteners. Space fasteners and anchors in accordance with industry standards.

- E. Set thresholds for exterior doors in full bed of butyl-rubber or polyisobutylene mastic sealant complying with requirements specified in Division 7 Section "Joint Sealers."
- F. Weatherstripping and Seals: Comply with manufacturer's instructions and recommendations to the extent installation requirements are not otherwise indicated.

END OF SECTION 06105

SECTION 07920
JOINT SEALERS

1.1 RELATED DOCUMENTS

- A. Instructions to Bidders, AIA Document A201, "The General Conditions of the Contract for Construction," 15th Edition, 1997, the Supplementary General Conditions and Division 1, General Requirements, are a part of this Section and shall be binding on the Contractor and/or Subcontractor who performs this work. Note also all Addenda.

1.2 SUMMARY

- A. This Section includes joint sealants for the following locations:
1. Exterior joints in vertical surfaces and nontraffic horizontal surfaces as indicated below:
 - a. Control joints and expansion joints in unit masonry where exposed to view.
 - b. Perimeter joints between unit masonry and frames of doors, windows, and louvers.
 - c. Control and expansion joints in soffits and overhead surfaces.
 - d. Other joints as indicated.
 2. Interior joints in vertical surfaces and horizontal nontraffic surfaces as indicated below:
 - a. Control joints on exposed interior surfaces of exterior walls.
 - b. Control joints in ceilings and overhead surfaces.
 - c. Perimeter joints of exterior openings.
 - d. Vertical control joints on exposed surfaces of interior unit masonry and concrete walls and partitions.
 - e. Perimeter joints of toilet fixtures
 - f. Perimeter joints of detention cell bunks, detention equipment and penalware.
 - g. All exposed joints between steel columns, masonry, drywall, or other dissimilar materials.
- B. Related Sections: The following Sections contain requirements that relate to this Section:
1. Section 05800 "Expansion Control" for building expansion and seismic control.
 2. Section 07270 "Firestopping" for fire-resistance-rated joint sealants.

1.3 SYSTEM PERFORMANCE REQUIREMENTS

- A. Provide elastomeric joint sealants that have been produced and installed to establish and to maintain watertight and airtight continuous seals without causing staining or deterioration of joint substrates.
- B. Provide joint sealants for interior applications that have been produced and installed to establish and maintain airtight continuous seals that are water resistant and cause no staining or deterioration of joint substrates.

1.4 SUBMITTALS

- A. Product data from manufacturers for each joint sealant product required.

1.5 QUALITY ASSURANCE

- A. Installer Qualifications: Engage an experienced Installer who has completed joint sealant applications similar in material, design, and extent to that indicated for Project that have resulted in construction with a record of successful in-service performance.
- B. Single Source Responsibility for Joint Sealant Materials: Obtain joint sealant materials from a single manufacturer for each different product required.

1.6 DELIVERY, STORAGE, AND HANDLING

- A. Deliver materials to Project site in original unopened containers or bundles with labels indicating manufacturer, product name and designation, color, expiration period for use, pot life, curing time, and mixing instructions for multicomponent materials.
- B. Store and handle materials in compliance with manufacturer's recommendations to prevent their deterioration or damage due to moisture, high or low temperatures, contaminants, or other causes.

1.7 PROJECT CONDITIONS

- A. Environmental Conditions: Notify Architect and do not proceed with installation of joint sealants under the following conditions:
 - 1. When ambient and substrate temperature conditions are outside the limits permitted by joint sealant manufacturer.
 - 2. When ambient and substrate temperature conditions are outside the limits permitted by joint sealant manufacturer or below 40 deg F (4.4 deg C).
 - 3. When joint substrates are wet.

- B. Joint Width Conditions: Notify Architect and do not proceed with installation of joint sealants where joint widths are less than allowed by joint sealant manufacturer for application indicated.
- C. Joint Substrate Conditions: Notify Architect and do not proceed with installation of joint sealants until contaminants capable of interfering with their adhesion are removed from joint substrates.

1.8 SEQUENCING AND SCHEDULING

- A. Sequence installation of joint sealants to occur not less than 21 nor more than 30 days after completion of waterproofing, unless otherwise indicated.

PART 2 - PRODUCTS

2.1 MATERIALS, GENERAL

- A. Compatibility: Provide joint sealants, joint fillers, and other related materials that are compatible with one another and with joint substrates under conditions of service and application, as demonstrated by sealant manufacturer based on testing and field experience.
- B. Colors: Provide color of exposed joint sealants to comply with the following:
 - 1. Provide selections made by Architect from manufacturer's full range of standard colors for products of types indicated.

2.2 ELASTOMERIC JOINT SEALANTS

- A. Elastomeric Sealant Standard: Provide manufacturer's standard chemically curing elastomeric sealants that comply with those requirements referencing ASTM 920 classifications for Type, Grade, Class, and Uses.
- B. Products: Subject to compliance with requirements, provide one of the following:
 - 1. Multi-Part, Non Sag Urethane Sealants:
 - a. "Dynatrol II", Pecora Corp.
 - b. "Sonolastic NP2", Sonneborn Building Products Division
 - c. "Dymeric Plus", Tremco.
 - 2. Multi-Part, Self Levelling Urethane Sealant:
 - a. "Sikaflex - 20 SL", Sika Corp.
 - b. "Sonolastic SL2", Sonneborn Building Products Division.

2.3 LATEX JOINT SEALANTS

- A. General: Provide manufacturer's standard one-part, nonsag, mildew-resistant, paintable latex sealant of formulation indicated that is recommended for exposed applications on interior and protected exterior locations and that accommodates indicated percentage change in joint width existing at time of installation without failing either adhesively or cohesively.
- B. Acrylic-Emulsion Sealant: Provide product complying with ASTM C 834 that accommodates joint movement of not more than 5 percent in both extension and compression for a total of 10 percent.
- C. Products: Subject to compliance with requirements, provide one of the following:
 - 1. Acrylic-Emulsion Sealant:
 - a. "AC-20", Pecora Corp.
 - b. "Sonolac," Sonneborn Building Products Div., ChemRex, Inc.
 - c. "Tremco Acrylic Latex 834, " Tremco, Inc.

2.4 JOINT SEALANT BACKING

- A. General: Provide sealant backings of material and type that are nonstaining; are compatible with joint substrates, sealants, primers and other joint fillers; and are approved for applications indicated by sealant manufacturer based on field experience and laboratory testing.
- B. Plastic Foam Joint Fillers: Preformed, compressible, resilient, nonstaining, nonwaxing, nonextruding strips of flexible plastic foam of material indicated below and of size, shape, and density to control sealant depth and otherwise contribute to producing optimum sealant performance:
 - 1. Open-cell polyurethane foam.
 - 2. Closed-cell polyethylene foam, nonabsorbent to liquid water and gas, nonoutgassing in unruptured state.
 - 3. Proprietary, reticulated, closed-cell polymeric foam, nonoutgassing, with a density of 2.5 pcf and tensile strength of 35 psi per ASTM D 1623, and with water absorption less than 0.02 gms/cc per ASTM C 1083.
 - 4. Any material indicated above.
- C. Bond-Breaker Tape: Polyethylene tape or other plastic tape as recommended by sealant manufacturer for preventing sealant from

adhering to rigid, inflexible joint filler materials or joint surfaces at back of joint where such adhesion would result in sealant failure. Provide self-adhesive tape where applicable.

2.5 SECURITY SEALANTS

- A. General: Provide manufacturer's standard rigid, two-part, high solids, high modulus epoxy resin compound that is recommended for high security areas of prisons and other security areas and that provides high abrasion resistance and "pick-proof" properties.
- B. Epoxy Resin Sealant: Provide product complying with ASTM C 881, Type I.
- C. Products: Subject to compliance with requirements, provide one of the following:
 - 1. Epoxy Resin Sealant:
 - a. "DynaPoxy EP-1200", Pecora Corp.

2.6 MISCELLANEOUS MATERIALS

- A. Primer: Material recommended by joint sealant manufacturer where required for adhesion of sealant to joint substrates indicated, as determined from preconstruction joint sealant-substrate tests and field tests.
- B. Cleaners for Nonporous Surfaces: Chemical cleaners acceptable to manufacturers of sealants and sealant backing materials, free of oily residues or other substances capable of staining or harming in any way joint substrates and adjacent nonporous surfaces, and formulated to promote optimum adhesion of sealants with joint substrates.
- C. Masking Tape: Nonstaining, nonabsorbent material compatible with joint sealants and surfaces adjacent to joints.

PART 3 - EXECUTION

3.1 EXAMINATION

- A. Examine joints indicated to receive joint sealants, with Installer present, for compliance with requirements for joint configuration, installation tolerances, and other conditions affecting joint sealant performance. Notify Architect and do not proceed with installation of joint sealants until unsatisfactory conditions have been corrected.

3.2 PREPARATION

- A. Surface Cleaning of Joints: Clean out joints immediately before installing joint sealants to comply with recommendations of joint sealant manufacturer and the following requirements:
 - 1. Remove all foreign material from joint substrates that could interfere with adhesion of joint sealant, including dust, paints (except for permanent, protective coatings tested and approved for sealant adhesion and compatibility by sealant manufacturer), old joint sealants, oil, grease, waterproofing, water repellents, water, surface dirt, and frost.
 - 2. Clean concrete, masonry, unglazed surfaces of ceramic tile, and similar porous joint substrate surfaces by brushing, grinding, blast cleaning, mechanical abrading, or a combination of these methods to produce a clean, sound substrate capable of developing optimum bond with joint sealants. Remove loose particles remaining from above cleaning operations by vacuuming or blowing out joints with oil-free compressed air.
 - 3. Remove laitance and form release agents from concrete.
 - 4. Clean metal, glass, porcelain enamel, glazed surfaces of ceramic tile, and other nonporous surfaces with chemical cleaners or other means that do not stain, harm substrates, or leave residues capable of interfering with adhesion of joint sealants.

- B. Joint Priming: Prime joint substrates where indicated or where recommended by joint sealant manufacturer based on preconstruction joint sealant-substrate tests or prior experience. Apply primer to comply with joint sealant manufacturer's recommendations. Confine primers to areas of joint sealant bond; do not allow spillage or migration onto adjoining surfaces.

- C. Masking Tape: Use masking tape where required to prevent contact of sealant with adjoining surfaces that otherwise would be permanently stained or damaged by such contact or by cleaning methods required to remove sealant smears. Remove tape immediately after tooling without disturbing joint seal.

3.3 INSTALLATION OF JOINT SEALANTS

- A. General: Comply with joint sealant manufacturer's printed installation instructions applicable to products and applications indicated, except where more stringent requirements apply.

- B. Installation of Sealant Backings: Install sealant backings to comply with the following requirements:

1. Install joint fillers of type indicated to provide support of sealants during application and at position required to produce the cross-sectional shapes and depths of installed sealants relative to joint widths that allow optimum sealant movement capability.
 - a. Do not leave gaps between ends of joint fillers.
 - b. Do not stretch, twist, puncture, or tear joint fillers.
 - c. Remove absorbent joint fillers that have become wet prior to sealant application and replace with dry material.
 2. Install bond breaker tape between sealants where backer rods are not used between sealants and joint fillers or back of joints.
- C. Installation of Sealants: Install sealants by proven techniques that result in sealants directly contacting and fully wetting joint substrates, completely filling recesses provided for each joint configuration, and providing uniform, cross-sectional shapes and depths relative to joint widths that allow optimum sealant movement capability. Install sealants at the same time sealant backings are installed.
- D. Tooling of Nonsag Sealants: Immediately after sealant application and prior to time skinning or curing begins, tool sealants to form smooth, uniform beads of configuration indicated, to eliminate air pockets, and to ensure contact and adhesion of sealant with sides of joint. Remove excess sealants from surfaces adjacent to joint. Do not use tooling agents that discolor sealants or adjacent surfaces or are not approved by sealant manufacturer.
1. Provide concave joint configuration per Figure 5A in ASTM C 1193, unless otherwise indicated.

3.4 CLEANING

- A. Clean off excess sealants or sealant smears adjacent to joints as work progresses by methods and with cleaning materials approved by manufacturers of joint sealants and of products in which joints occur.

3.5 PROTECTION

- A. Protect joint sealants during and after curing period from contact with contaminating substances or from damage resulting from construction operations or other causes so that they are without deterioration or damage at time of Substantial Completion. If, despite such protection, damage or deterioration occurs, cut out and remove damaged or deteriorated joint sealants immediately so that and installations with repaired areas are indistinguishable from original work.

3.6 GUARANTEE AND CERTIFICATION

- A. This Contractor shall guarantee **in writing** that all sealant work will be free from defects of materials and workmanship for a period of five (5) years. The following types of failure will be adjusted:
1. Leakage, cracking, crumbling, melting, shrinking or running of caulking, or staining of adjacent work by caulking.
- B. This Contractor shall repair and replace work which becomes defective during guarantee term without cost to the Owner.

3.7 SCHEDULE

- A. Exterior Joints:
1. Masonry to masonry: Multi-Part, Non-Sag Urethane Sealant.
 2. Masonry to door frames: Multi-Part, Non-Sag Urethane Sealant
 3. All expansion and control joints: Multi-Part, Non-Sag Urethane Sealant
 4. Metal frame and louver perimeters: Multi-Part, Non-Sag Urethane Sealant
 5. All exposed joints between dissimilar materials: MultiPart, Non-Sag Urethane Sealant
- B. Interior Joints
1. Masonry to door frames: Acrylic-Emulsion Sealant
 2. Masonry or drywall to window frames: Acrylic-Emulsion Sealant
 3. Masonry to drywall: Acrylic-Emulsion Sealant
 4. All expansion and control joints: Acrylic-Emulsion Sealant
 5. Steel frame and louver perimeters: Acrylic-Emulsion Sealant
 6. Plumbing fixtures: Acrylic-emulsion Mildew-Resistant Sealant
 7. Detention cell / cell bunks / detention fixtures: Epoxy Resin Sealant (apply only after painting)
 8. All exposed joints between steel columns and masonry, drywall or other dissimilar materials: Urethane Sealant or Acrylic-Emulsion Sealant if in contact with epoxy paint.

END OF SECTION 07920

SECTION 09900
PAINTING

PART 1 -GENERAL

1.1 RELATED DOCUMENTS

- A. Instructions to Bidders, AIA Document A201, "The General Conditions of the Contract for Construction," 15th Edition, 1997, the Supplementary General Conditions and Division 1, General Requirements, are a part of this Section and shall be binding on the Contractor and/or Subcontractor who performs this work. Note also all Addenda.

1.2 WORK INCLUDED

- A. This Section includes surface preparation, all necessary materials and painting for all interior surfaces in new construction where so specified. The extent of painting work is shown on Drawings/ Schedules. Work shall include: latex wall and High performance Ceiling paint –**Eminence** by Sherwin-Williams (A27W3815), gypsum board wall, masonry walls, steel doors and frames – Pro Industrial Multi-surface Acrylic
- B. Manufacturer's products and colors shall be as noted in Drawings/ Schedules as shown and specified.
- C. Related Sections: The following sections contain requirements that relate to this section:
1. Division 4 for painting of Unit Masonry.
 2. Division 5 for painting of Metal Fabrications.
 3. Division 8 for painting of Steel Doors and Frames.

1.3 WORK NOT INCLUDED

- A. Metal surfaces of anodized aluminum, stainless steel, chromium plate, copper and similar finished materials will not require painting under this Section, unless so noted.
- B. Do not paint the moving parts of operating units, mechanical or electrical parts such as valve operators, linkages, sensing devices and motor shafts.
- C. Do not paint over required labels or equipment identification, performance rating name or nomenclature plates.
- D. Painting not required for shop finished millwork items.
- E. Do not paint ceramic tile or similar finished materials.

1.4 SUBMITTALS

- A. General: Submit the following in accordance with Conditions of Contract and Division 1 Specification Sections.
 - 1. Materials data sheet for each type of product specified.
 - 2. Samples for verification purposes of each type of exposed finish required, prepared on samples of size indicated below. Where finishes involve normal color and texture variations, include sample sets showing full range of variations expected. Provide 3 sets of samples.
 - a. 8"x10" samples of each paint color.

1.5 QUALITY ASSURANCE

- A. Installer Qualifications: Engage an experienced Installer who has successfully completed painting projects similar in material, design, and extent to those indicated for Project. Installer shall thoroughly review Contract Documents and be familiar with structure and all necessary requirements for attachment to same.
- B. Fire-Performance Characteristics: Conform to Building Code for Flame Rating Requirement for finishes.
- E. Coordination of Work: Coordinate work with other construction.

1.6 DELIVERY, STORAGE, AND HANDLING

- A. Deliver paint materials and floor system materials to project site in original, labeled, unopened packages and store them in a fully enclosed space where they will be protected against damage. Labeling to include manufacturer's name, type of paint, brand name, color designation, drying time, clean up and instructions for mixing and use.
- B. Store paint materials and floor system materials at a minimum ambient temperature of 45 degrees F and a maximum ambient temperature of 90 degrees F in a well-ventilated area, unless otherwise directed by manufacturer's instructions.
- C. Take precautionary measures to prevent fire hazards and spontaneous combustion.

1.7 PROJECT CONDITIONS

- A. Provide continuous ventilation and heating of space to maintain surface and ambient temperature above 65 degrees F for 24 hours before, during and 48 hours after application of finishes, unless otherwise indicated by manufacturer or specifications herein.
- B. Provide lighting level of 80 foot-candles measured mid-height at substrate surface.

1.8 EXTRA MATERIALS

- A. Deliver extra materials to Owner. Furnish extra materials described below that match products installed, are packaged with protective covering for storage, and are identified with appropriate labels.
 - 1. Minimum of one quart of each finish specified. Labeling shall include manufacturer, type, color name and number.

PART 2 - PRODUCTS

2.1 MANUFACTURERS:

- A. Acceptable Manufacturers:
 - 1. The Sherwin Williams Company
 - 2. Benjamin Moore and Company
 - 3. Pittsburgh Paints

2.2 MATERIALS- GENERAL

- A. Provide products which will meet all Federal regulations for amount of lead in paint (Less than 0.06% lead in non-volatile ingredients).
- B. Coatings: Provide best quality grade of various types of coatings. Materials not displaying manufacturer's identification as a standard, best-grade product will not be accepted.
- C. Use only thinners approved by paint manufacturers for applications intended and use only within recommended limits.

PART 3 - EXECUTION

3.1 EXAMINATION

- A. Examine substrates and verify that conditions are ready to receive work as instructed by the product manufacturer.
- B. Beginning of installation means acceptance of substrate.

3.2 PREPARATION:

- A. Remove electrical plates, hardware, light fixture trim and fitting prior to preparing finishes for painting.
- B. Correct minor defects and clean surfaces which may affect the work of this section.
- C. Shellac and seal marks that may bleed through surface finishes.
- D. Gypsum Board Surfaces: Latex fill minor defects. Spot prime defects after repair.
- E. Galvanized Surfaces: Remove surface contamination and oils and wash with solvent. Apply coat of etching primer.
- F. Concrete and Unit Masonry Surfaces Scheduled to Receive Paint Finish: Remove loose dirt, loose mortar, scale, salt, or alkali powder or other foreign matter. Remove oil or grease with a solution of trisodium phosphate. Rinse well and allow to dry.
- G. Uncoated Steel and Iron Surfaces: Remove grease, scale, dirt and rust. Where heavy coatings of scale are evident, remove by wire brushing. Clean with solvent. Spot prime paint after repairs.
- H. Shop Primed Steel Surfaces: Sand and scrape to remove loose primer and rust. Feather edges to make touch-up patches inconspicuous. Clean surfaces with solvent. Prime bare steel surfaces.
- I. Interior Wood Items (Painted): Wipe off dust and grit prior to priming. Seal knots, pitch streaks and sappy sections with sealer. Fill nail holes and cracks after primer has dried; sand between coats.
- J. Interior Wood Items (Clear Finished): Clean surfaces of dirt, oil, and other foreign substances with scrapers, mineral spirits and sandpaper, as required. Sand surfaces exposed to view smooth and dust off. Fill nail holes. Sand smooth and sand lightly between coats.
- K. Wood and Metal Doors Scheduled for Painting: Seal top and bottom edges with primer. Seal wood door edges after trimming to prevent absorption of moisture.

3.3 PROTECTION

- A. Protect elements surrounding the work of this Section from damage or disfiguration.
- B. Repair damage to other surfaces caused by work of this Section.
- C. Furnish drop cloths, shields and protective methods to prevent spray or droppings from other surfaces.
- D. Remove all empty paint containers from site.

3.4 APPLICATION:

- A. Apply all products in accordance with manufacturer's instructions.
- B. No work shall be performed in spaces that are not broom clean and free of dust and waste.
- C. Apply each coat to a uniform finish, free of brush or roller marks, drops, runs or sags.
- D. Sand lightly between coats to achieve required finish.
- E. Allow applied coat to dry before next coat is applied. Allow a minimum of 48 hours for enamel paints to dry before recoating.
- F. Where clear finishes are required, tint fillers to match wood. Work fillers into the grain before set. Wipe excess from surface.
- G. Prime back surfaces of interior woodwork scheduled to receive stain or varnish with gloss varnish reduced to 24 percent with mineral spirits with primer paint.
- H. Finish doors on tops, bottoms and side edges same as exterior faces.
- I. As work proceeds, promptly remove paint where spilled, splashed or spattered.
- J. Collect cloths and materials which may constitute a fire hazard, place in a closed metal container and remove daily from site.

3.5 CLEANING

- A. At the completion of work of other trades, touch-up and restore all damaged or defaced painted surfaces.

3.6 SCHEDULE-INTERIOR SURFACES

- 1. All surface except for ceiling to be painted with self priming Multi-Surface Acrylic by Sherwin- Williams or approved other

END OF SECTION 09900- PAINTING

SECTION 10155
TOILET COMPARTMENTS

PART 1 - GENERAL

1.1 RELATED DOCUMENTS

- A. Instructions to Bidders, AIA Document A201, "The General Conditions of the Contract for Construction," 15th Edition, 1997, the Supplementary General Conditions and Division 1, General Requirements, are a part of this Section and shall be binding on the Contractor and/or Subcontractor who performs this work. Note also all Addenda.

1.2 SUMMARY

- A. This Section includes stock, manufactured toilet compartments.
- B. Types of toilet partitions include:
 - 1. Plastic toilet compartment partitions for following applications:
 - a. Toilet enclosure
 - b. Urinal screens
- C. Style of Toilet Compartment, include:
 - 1. Floor mounted, overhead braced.
- D. Toilet accessories, such as toilet paper holders and grab bars are specified in Section 10800 "Toilet Accessories".
- E. Related Requirements:
 - 1. Division 03 Section "Cast in Place Concrete" for compartment anchorage to concrete substrates.
 - 2. Division 04 Section "Unit Masonry" for compartment anchorage to masonry substrates.

1.3 SUBMITTALS

- A. General: Submit the following in accordance with Conditions of Contract and Division 1 Specification Sections.
- B. Product data for materials, fabrication, and installation including catalog cuts of anchors, hardware, fastenings, and accessories.
- C. Shop drawings for fabrication and erection of toilet compartment assemblies not fully described by product drawings, templates, and instructions for installation of anchorage devices built into other work.

- D. Samples of full range of colors for each type of unit required. Submit 6-inch-square samples of each color and finish on same substrate to be used in work, for color verification after selections have been made.

1.4 INFORMATIONAL SUBMITTALS

- A. Warranty: Sample of special warranty.

1.5 CLOSEOUT SUBMITTALS

- A. Maintenance and cleaning instructions.

1.4 QUALITY ASSURANCE

- A. Field Measurements: Take field measurements prior to preparation of shop drawings and fabrication, where possible, to ensure proper fitting of work. However, allow for adjustments where taking of field measurements before fabrication might delay work.
- B. Coordination: Furnish inserts and anchorages which must be built into other work for installation of toilet compartments and related items. Coordinate delivery with other work to avoid delay.

PART 2 - PRODUCTS

2.1 MANUFACTURERS

- A. Manufacturer: Subject to compliance with requirements, provide products by one of the following:
 - 1. Plastic toilet compartment partitions:
 - a. American Sanitary Partition Corp.
 - b. Bobrick Washroom Equip, Inc.
 - c. Bradley Corporation, The Mills Company

2.2 MATERIALS

- A. General: Provide materials which have been selected for surface flatness and smoothness. Exposed surfaces which exhibit pitting, seam marks, roller marks, stains, discolorations, telegraphing of core material, or other imperfections on finished units are not acceptable.

- B. Plastic Panels: High density polyethylene (HDPE) suitable for exposed applications, waterproof, non-absorbent, and graffiti-resistant textured surface, Class C
- C. Hardware and Accessories: Heavy duty operating hardware and accessories of ASTM 162, Type 302/304 Stainless Steel, #4 satin finish.
- D. Anchorages and Fasteners: Manufacturer's standard exposed fasteners of stainless steel, chromium-plated steel, or brass, finished to match hardware, with theft-resistant-type heads and nuts. For concealed anchors, use stainless steel.
- E. Fire resistance characteristics per ASTM E-84 Tests: flame spread of 0-25 max. smoke density 100 max.
- F. General: Furnish doors, fabricated for compartment system. Furnish units with cutouts, drilled holes, and internal reinforcement to receive hardware and accessories as indicated.
- G. Door Dimensions: Unless otherwise indicated, furnish 24-inch-wide in-swinging doors for ordinary toilet stalls and 32-inch-wide (clear opening) out-swinging doors for stalls equipped for use by handicapped.
- H. Hardware: Furnish hardware for each compartment to comply with ANSI A117.1 and U.S. ADA Guidelines for handicapped accessibility and as follows:
 - 1. Hinges: Continuous hinge full height of door. Type 304 satin finish stainless steel; extra heavy duty 16 gauge. Through bolted to door and stile with 12 theft-resistant, one way screws fastened into threaded metal inserts.
 - 2. Latch and Keeper: Door latch with shock resistant nylon track into 1 inch wide keeper formed from one piece 1/8 inch 11 gauge stainless steel. Keeper shall be through bolted to stile with theft resistant one-way screws fastened into threaded metal inserts. Vinyl coated door stops.
 - 3. Coat Hook: Manufacturer's standard unit, combination hook and rubber-tipped bumper, sized to prevent door hitting mounted accessories.
 - 4. Door Pull: Manufacturer's standard unit for out-swinging doors. Provide pulls on both faces of handicapped compartment doors.
 - 5. Pilaster Shoes: ASTM A 167, Type 304 stainless steel not less than 4 inches high, finished to match hardware.
 - 6. Overhead bracing: Continuous stainless steel at all sides and subdivisions.

2.3 FINISH

- A. Color: One of manufacturer's standard colors in each room, as selected by Architect.

PART 3 - EXECUTION

3.1 QUALITY ASSURANCE

- A. Manufacturer Qualifications: Approved manufacturer listed in this section, with minimum 5 years experience in the manufacture of toilet compartments.
- B. Manufacturer Qualifications: Approved manufacturer listed in this section, with minimum 5 years experience in the manufacture of toilet compartments. Manufacturers seeking approval must submit the following in accordance with Instructions to Bidders and Division 01 requirements:
 - 1. Product data, including test data from qualified independent testing agency indicating compliance with requirements.
 - 2. Samples of each component of product specified.
 - 3. List of successful installations of similar products available for evaluation by Architect.
- C. Installers Qualifications: Experienced Installer regularly engaged in installation of toilet compartments for minimum 3 years.
- D. Source Limitations: Obtain toilet compartment components and accessories from single manufacturer.

3.2 WARRANTY

- A. Special Manufacturer's Warranty: Provide manufacturer's standard form in which manufacturer agrees to repair or replace products that fail in materials or workmanship during the following period after substantial completion:
 - 1. Plastic Toilet Partitions: Against corrosion, breakage, and delamination: 15 years.

3.3 INSTALLATION

- A. General: Comply with manufacturer's recommended procedures and installation sequence. Install compartment units rigid, straight, plumb, and

level. Provide clearances of not more than 1/2 inch between pilasters and panels, and not more than 1 inch between panels and walls.

3.4 ADJUST AND CLEAN

- A. Hardware Adjustment: Adjust and lubricate hardware for proper operation. Set hinges on in-swinging doors to hold open approximately 30 degrees from closed position when unlatched. Set hinges on out-swinging doors (and entrance swing doors) to return to fully closed position.

- B. Clean exposed surfaces of partition system components using materials and methods recommended by manufacturer, and provide protection as necessary to prevent damage during remainder of construction period.

END OF SECTION 10155

SECTION 10200
LOUVERS AND VENTS

PART 1 - GENERAL

1.1 RELATED DOCUMENTS

- A. Instructions to Bidders, AIA Document A201, "The General Conditions of the Contract for Construction," 15th Edition, 1997, the Supplementary General Conditions and Division 1, General Requirements, are a part of this Section and shall be binding on the Contractor and/or Subcontractor who performs this work. Note also all Addenda.

1.2 SUMMARY

- A. This Section includes the following:
1. Fixed metal, storm resistant wall louvers.
- B. Related Sections: The following Sections contain requirements that relate to this Section:
1. Section 07901 "Joint Sealants" for sealants installed in perimeter joints between louver frames and adjoining construction.
 2. Division 15 Section for ductwork connected to metal wall louvers.

1.3 DEFINITIONS

- A. Louver Terminology: Refer to Air Movement and Control Association (AMCA) 501 for definitions of terms for metal louvers not otherwise defined in this Section or in referenced standards.

1.4 PERFORMANCE REQUIREMENTS

- A. As follows, determined by testing on a (1) meter wide by one (1) meter high per BSRIA. The louver manufacturer shall submit certified test data. The louver tested shall be with a rain fall rate of 3 inches per hour and a wind directed at the face of the louver of 29.1 mph. The test data will show that at a ventilation rate of 8224 cfm: Louver effectiveness = 100%.

1.5 SUBMITTALS

- A. General: Submit each item in this Article according to the Conditions of the Contract and Division 1 Specification Sections.
- B. Product data for each type of product specified.

- C. Shop drawings of louver units and accessories. Include plans, elevations, sections, and details showing profiles, angles, and spacing of louver blades; unit dimensions related to wall openings and construction; free areas for each size indicated; profiles of frames at jambs, heads, and sills; and anchorage details and locations.
- D. Samples for initial selection in the form of manufacturer's color charts showing the full range of colors available for units with factory-applied color finishes.
- E. Product test reports evidencing compliance of units with performance requirements indicated.
- F. Product certificates signed by louver manufacturers certifying that their products comply with the specified requirements and are licensed to bear the AMCA seal based on tests made according to AMCA 500 and complying with the AMCA Certified Ratings Program.
- G. Qualification data for firms and persons specified in the "Quality Assurance" Article to demonstrate their capabilities and experience.

1.6 QUALITY ASSURANCE

- A. Single-Source Responsibility: Obtain louvers and vents from one source and by a single manufacturer where alike in one or more respects regarding type, design, and factory-applied color finish.
- B. SMACNA Standard: Comply with SMACNA "Architectural Sheet Metal Manual" recommendations for fabrication, construction details, and installation procedures.

1.7 PROJECT CONDITIONS

- A. Field Measurements: Check actual louver openings by accurate field measurements before fabrication, and show recorded measurements on final shop drawings. Coordinate fabrication schedule with construction progress to avoid delaying the Work.
 - 1. Where field measurements cannot be made without delaying the Work, guarantee opening dimensions and proceed with fabricating louvers without field measurements. Coordinate construction to ensure that actual opening dimensions correspond to guaranteed dimensions.

PART 2 - PRODUCTS

2.1 MANUFACTURERS

- A. Manufacturers: Subject to compliance with requirements, provide products by one of the following:
 - 1. Louvers:
 - a. Airstream Products Div., Penn Ventilator Co., Inc.
 - b. Construction Specialties, Inc.
 - c. Ruskin Mfg., Tomkins Industries, Inc.
- B. For the purpose of establishing performance criteria the Contract Drawings and specifications have been based on Construction Specialties, Inc., Model RS-8400.

2.2 MATERIALS

- A. Aluminum Extrusions: ASTM B 221 (ASTM 3 221M) . Alloy 6063-T5 or T-52.
- B. Fasteners: Of same basic metal and alloy as fastened metal or 300 series stainless steel, unless otherwise indicated. Do not use metals that are corrosive or incompatible with joined materials.
 - 1. Use types and sizes to suit unit installation conditions.
 - 2. Use Phillips flat-head screws for exposed fasteners, unless otherwise indicated.
- C. Anchors and Inserts: Of type, size, and material required for type of loading and installation indicated. Use nonferrous metal or hot-dip galvanized anchors and inserts for exterior installations and elsewhere as required for corrosion resistance. Use toothed steel or expansion bolt devices for drilled-in-place anchors.

2.3 FABRICATION, GENERAL

- A. General: Fabricate louvers and vents to comply with requirements indicated for design, dimensions, materials, joinery, and performance.
- B. Assemble louvers in shop to minimize field splicing and assembly. Disassemble units as necessary for shipping and handling limitations. Clearly mark units for re-assembly and coordinated installation.
- C. Maintain equal louver blade spacing to produce uniform appearance.
- D. Fabricate frames, including integral sills, to fit in openings of sizes indicated, with allowances made for fabrication and installation tolerances of louvers, adjoining construction, and perimeter sealant joints.

- E. Include supports, anchorages, and accessories required for complete assembly.
- F. Provide sill extensions and loose sills made of same material as louvers where indicated or required for drainage to exterior and to prevent water penetrating to interior.
- G. Join frame members to one another and to fixed louver blades as follows, unless otherwise indicated or size of louver assembly makes bolted connections between frame members necessary:
 - 1. With fillet welds, concealed from view; or mechanical fasteners; or a combination of these methods; as standard with louver manufacturer.

2.4 FIXED, EXTRUDED-ALUMINUM WALL LOUVERS

- A. Fixed, Extruded-aluminum wall louvers, horizontal, Storm resistant Fixed Blade Louver designed to collect and drain water to exterior at sill by means of multiple gutters in blades and channels in jambs and mullions, complying with the following requirements:
 - 1. Louver Depth: 8 inches
 - 2. Frame Type: Channel type, unless otherwise indicated.
 - 3. Frame Thickness: 0.081 inch
 - 4. Blade Thickness: 0.0674 inch
- B. Subject to compliance with requirements, provide by the following:
 - 1. Construction Specialties, Inc.
- C. Provide sill flashing pans 4 inches high by full depth formed from minimum .050 inch thick aluminum. Sill pan to have welded side panels.

2.5 LOUVER SCREENS

- A. General: Provide each exterior louver with louver screens complying with the following requirements:
 - 1. Screen Location for Fixed Louvers: Interior face, unless otherwise indicated.
 - 2. Screening Type: Insect screening and Bird screening.
- B. Secure screens to louver frames with stainless-steel machine screws, spaced 6 inches (150 mm) maximum from each corner and at 12 inches (300 mm) o.c. between.

- C. Louver Screen Frames: Fabricate screen frames with mitered corners to louver sizes indicated and to comply with the following requirements:
 - 1. Metal: Same kind and form of metal as indicated for louver frames to which screens are attached.
 - a. Reinforce extruded-aluminum screen frames at corners with clips.
 - 2. Finish: Mill finish, unless otherwise indicated.
 - 3. Type: Rewireable frames with a driven spline or insert for securing screen mesh.
- D. Louver Screening for Aluminum Louvers: Fit aluminum louver screen frames with screening covering louver openings and complying with the following requirements:
 - 1. Bird Screening: 1/2-inch- (12.7-mm-) square mesh formed with 0.063-inch- (1.60-mm-) diameter aluminum wire.
 - 2. Insect Screening: 18-by-16 (1.4-by-1.6-mm) mesh formed with 0.012-inch- (0.30-mm-) diameter aluminum wire.

2.6 FINISHES, GENERAL

- A. Comply with NAAMM "Metal Finishes Manual" for recommendations relative to applying and designating finishes.
- B. Finish louvers after assembly.

2.7 ALUMINUM FINISHES

- A. Finish designations prefixed by AA conform to the system established by the Aluminum Association for designating aluminum finishes.
- B. High-Performance Organic Coating Finish: AA-CI2C42RIx (Chemical Finish: cleaned with inhibited chemicals; Chemical Finish: acid chromate-fluoride-phosphate conversion coating; Organic Coating: as specified below). Prepare, pretreat, and apply coating to exposed metal surfaces to comply with coating and resin manufacturer's instructions.
 - 1. Fluoropolymer 2-Coat Coating System: Manufacturer's standard 2-coat, thermocured system composed of specially formulated inhibitive primer and fluoropolymer color topcoat containing not less than 70 percent polyvinylidene fluoride resin by weight; complying with AAMA 605.2.

- a. Color and Gloss: As selected by Architect from manufacturer's full range of standard choices for color and gloss.

PART 3 - EXECUTION

3.1 PREPARATION

- A. Coordinate setting drawings, diagrams, templates, instructions, and directions for installation of anchorages. Coordinate delivery of such items to Project site.

3.2 INSTALLATION

- A. Locate and place louver units plumb, level, and at indicated alignment with adjacent work.
- B. Use concealed anchorages where possible. Provide brass or lead washers fitted to screws where required to protect metal surfaces and to make a weathertight connection.
- C. Form closely fitted joints with exposed connections accurately located and secured.
- D. Provide perimeter reveals and openings of uniform width for sealants and joint fillers, as indicated.
- E. Repair finishes damaged by cutting, welding, soldering, and grinding operations required for fitting and jointing. Restore finishes so there is no evidence of corrective work. Return items that cannot be refinished in the field to the shop, make required alterations, and refinish entire unit, or provide new units.
- F. Protect nonferrous-metal surfaces from corrosion or galvanic action by applying a heavy coating of bituminous paint on surfaces that will be in contact with concrete, masonry, or dissimilar metals.

3.3 ADJUSTING AND PROTECTION

- A. Protect louvers and vents from damage of any kind during construction period including use of temporary protective coverings where needed and approved by louver manufacturer. Remove protective covering at time of Substantial Completion.

- B. Restore louvers and vents damaged during installation and construction period, so that no evidence remains of correction work. If results of restoration are unsuccessful, as judged by Architect, remove damaged units and replace with new units.
 - 1. Clean and touch up minor abrasions in finishes with air-dried coating that matches color and gloss of, and is compatible with, factory-applied finish coating.

3.4 CLEANING

- A. Periodically clean exposed surfaces of louvers and vents that are not protected by temporary covering to remove fingerprints and soil during construction period. Do not let soil accumulate until final cleaning.
- B. Before final inspection, clean exposed surfaces with water and a mild soap or detergent not harmful to finishes. Rinse surfaces thoroughly and dry.

END OF SECTION 10200

SECTION 10800
TOILET AND BATH ACCESSORIES

PART 1 - GENERAL

1.1 RELATED DOCUMENTS

- A. Instructions to Bidders, AIA Document A201, "The General Conditions of the Contract for Construction," 15th Edition, 1997, the Supplementary General Conditions and Division 1, General Requirements, are a part of this Section and shall be binding on the Contractor and/or Subcontractor who performs this work. Note also all Addenda.

1.2 SUMMARY

- A. This Section includes furnishing toilet and bath accessory items as shown on the drawings and as specified herein.
- B. Installation of toilet and bath accessories is specified in Section 06105, "Miscellaneous Carpentry".
- C. Installation of wood blocking is specified in Section 06105, "Miscellaneous Carpentry".
- D. Toilet compartments and related accessories are specified in Section 10155, "Toilet Compartments"
- E. Division 04 Section "Unit Masonry" for anchorage to masonry substrates.

1.3 SUBMITTALS

- A. General: Submit the following according to Conditions of Contract and Division 1 Specifications Sections.
- B. Product data for each toilet accessory item specified, including construction details relative to materials, dimensions, gages, profiles, mounting method, specified options, and finishes.
- C. Schedule indicating types, quantities, sizes, and installation locations (by room) for each toilet accessory item to be provided for project.
- D. Setting drawings where cutouts are required in other work, including templates, substrate preparation instructions, and directions for preparing cutouts and installing anchorage devices.
- E. Maintenance instructions including replaceable parts and service recommendations.

1.4 QUALITY ASSURANCE

- A. Inserts and Anchorages: Furnish accessory manufacturers' standard inserts and anchoring devices that must be set in concrete or built into masonry. Coordinate delivery with other work to avoid delay.
- B. Single-Source Responsibility: Provide products of same manufacturer for each type of accessory unit and for units exposed to view in same areas, unless otherwise acceptable to Architect.
- C. Catalog Standards: Manufacturer's catalog numbers may be shown on drawings for convenience in identifying certain work. Unless modified by notation on drawings or otherwise specified, catalog description for indicated number constitutes requirements for each item.
 - 1. The use of catalog numbers and specific requirements set forth in drawings and specifications are not intended to preclude the use of any other acceptable manufacturer's product or procedures which may be equivalent, but are given for purpose of establishing standard of design and quality for materials, construction, and workmanship.
 - 2. The approval of other listed manufacturers, products does not relieve the Contractor from compliance with the detailed requirements of this Section.

1.5 PROJECT CONDITIONS

- A. Coordination: Coordinate accessory locations, installation, and sequencing with other work to avoid interference with and ensure proper installation, operation, adjustment, cleaning, and servicing of toilet accessory items.

1.6 WARRANTY

- A. Warranty: Submit a written warranty executed by mirror manufacturer, agreeing to replace any mirrors that develop visible silver spoilage defects within warranty period.
- B. Warranty Period: 15 years from date of Substantial Completion.
- C. The warranty shall not deprive the Owner of other rights the owner may have under other provisions of the Contract Documents and will be in addition to and run concurrent with other warranties made by the Contractor under requirements of the Contract Documents.

PART 2 - PRODUCTS

2.1 ACCEPTABLE MANUFACTURERS

- A. Manufacturers: Subject to compliance with requirements, provide toilet accessories by one of the following:
 - 1. American Specialties, Inc. (ASI)
 - 2. Bobrick Washroom Equipment, Inc. (Bobrick), or equal.

2.2 MATERIALS, GENERAL

- A. Stainless Steel: AISI Type 302/304, with polished No. 4 finish, 0.034-inch (22-gage) minimum thickness.
- B. Brass: Leaded and unleaded, flat products, ASTM B 19; rods, shapes, forgings, and flat products with finished edges, ASTM B 16; Castings, ASTM B 30.
- C. Sheet Steel: Cold-rolled, commercial quality ASTM A 366, 0.04-inch (20-gage) minimum. Surface preparation and metal pretreatment as required for applied finish.
- D. Galvanized Steel Sheet: ASTM A 527, G60.
- E. Chromium Plating: Nickel and chromium electro-deposited on base metal, ASTM B 456, Type SC 2.
- F. Galvanized Steel Mounting Devices: ASTM A 153, hot-dip galvanized after fabrication.
- G. Fasteners: Screws, bolts, and other devices of same material as accessory unit, or of galvanized steel where concealed.

2.3 TOILET TISSUE DISPENSERS (T.P.D.)

- A. Stainless Steel Twin Jumbo Roll Toilet Tissue Dispenser:
 - 1. Mounting: Surface mounted, concealed anchorage.
 - 2. Cabinet: 18-8 S. type 304, 20 gauge stainless steel with satin finish. Equipped with a tumbler lock keyed like other toilet accessories.
 - 3. Capacity: Spindles accommodate two toilet tissue rolls up to 10" diameter with 3" diameter core, or remove outer spindle from the inner spindles to accommodate 2 1/4" diameter core rolls.
 - 4. Subject to conformance with requirements, provide "Model B-2892, Bobrick.

2.6 GRAB BARS (G.B.)

- A. Stainless Steel Type: Provide grab bars with wall thickness not less than 0.05 inch (18 gage) and as follows:
1. Mounting: Concealed, manufacturer's standard flanges and anchorages.
 2. Clearance: 1-1/2-inch clearance between wall surface and inside face of bar.
 3. Gripping Surfaces: Manufacturer's standard nonslip texture.
 4. Heavy-Duty Size: Outside diameter of 1-1/2 inches.
 5. Subject to conformance with requirements, provide grab bar units manufactured by Bobrick Washroom Equipment, Inc.:
 - a. "Model B-6806x36", for rear wall installation
 - b. "Model B-6806x42", for side wall installation
 - c. "Model B-6806 x18", for side wall vertical installation
 - d. "Model B-6897", for side and rear wall shower installation

2.7 ROBE HOOKS (R.H.)

- A. Single-Prong Single Robe Hook: Heavy-duty satin finished stainless steel single-prong robe hook; rectangular wall bracket with backplate for concealed mounting.
1. Subject to conformance with requirements, provide "Model B-2116", Bobrick.

2.8 SOAP DISPENSERS (S.D.)

- A. Wall Mounted:
1. Surface mounted soap dispenser for liquid and lotion soaps and detergents.
 2. Capacity: 40 fluid ounces.
 3. Construction: 18-8 S, type 304, 22 gauge stainless steel with satin finish. Body is drawn, one-piece seamless construction. Back plate has mounting bracket attached. Furnished with concealed wall plate.

2.9 MIRRORS (M.W.F.)

- A. Wall Mounted Mirrors with Frames:
1. Subject to conformance with requirements, provide "Model B-166-1830", BOBRICK.

2.9 BABY CHANGING STATION (B.C.S.)

- A. Wall Mounted:
1. Subject to conformance with requirements, provide "Model KB200-01", KOALA KARE.
 2. Quantity: Provide one (1) unit for Male Bathroom, one (1) unit for Female Bathroom.

1.10 ELECTRIC HAND DRYER (E.H.D.)

- A. Wall Mounted:
1. Subject to conformance with requirements, provide "Model XLERATOR BMC XL-BW", EXCEL DRYER INC..
 2. Quantity: Provide one (1) unit for Male Bathroom, one (1) unit for Female Bathroom.

2.14 FABRICATION

- A. General: Only a maximum 1-1/2-inch-diameter, unobtrusive stamped manufacturer logo, as approved by Architect, is permitted on exposed face of toilet or bath accessory units. on either interior surface not exposed to view or back surface, provide additional identification by either a printed, waterproof label or a stamped nameplate, indicating manufacturer's name and product model number.
- B. Surface-Mounted Toilet Accessories, General: Except where otherwise indicated, fabricate units with tight welded seams and joints, exposed edges rolled. Hang doors or access panels with continuous stainless steel piano hinge. Provide concealed anchorage wherever possible.
- C. Framed Mirror Units, General: Fabricate frames for glass mirror units to accommodate wood, felt, plastic, or other glass edge protection material. Provide mirror backing and support system that will permit rigid, tamperproof glass installation and prevent moisture accumulation, as follows:
1. Provide galvanized-steel backing sheet, not less than 0.034 inch (22 gage) and full mirror size, with non absorptive filler material. Corrugated cardboard is not an acceptable filler material.
- D. Mirror Unit Hangers: Provide system for mounting mirror units that will permit rigid, tamperproof, and theft proof installation, as follows:
1. Heavy-duty wall brackets of galvanized steel, equipped with concealed locking devices requiring a special tool to remove.

- E. Keys: Provide universal keys for access to toilet accessory units requiring internal access for servicing, resupply, etc. Provide minimum of six keys to Owner's representative.

PART 3 - EXECUTION

3.1 INSTALLATION

- A. Install toilet accessory units according to manufacturers, instructions, using fasteners appropriate to substrate as recommended by unit manufacturer. Install units plumb and level, firmly anchored in locations and at heights indicated.
 - 1. Reinforcement of stud walls to support wall-mounted cabinets will be accomplished during wall erection by trade involved; however, indicating accurate location and sizing of reinforcement is responsibility of toilet and bath accessories installer.
 - 2. Install toilet accessory units furnished by the owner using fasteners appropriate to substrate as required.
- B. Secure mirrors to walls in concealed, tamperproof manner with special hangers, toggle bolts, or screws. Set units plumb, level, and square at locations indicated, according to manufacturer's instructions for type of substrate involved.
- C. Install grab bars to withstand a downward load of at least 250 lbs, complying with ASTM F 446.

3.2 ADJUSTING AND CLEANING

- A. Adjust toilet accessories for proper operation and verify that mechanisms function smoothly. Replace damaged or defective items.
- B. Clean and polish all exposed surfaces strictly according to manufacturer's recommendations after removing temporary labels and protective coatings.

END OF SECTION 10800

SECTION 15010
BASIC MECHANICAL REQUIREMENTS

PART 1 - GENERAL

1.1 RELATED DOCUMENTS

- A. Drawings and general provisions of Contract, including General Conditions apply to this section.

1.2 DESCRIPTION

- A. General: Materials and methods for performance of mechanical work related to HVAC systems installation.
- B. Provide complete and operational mechanical systems including, but not limited to, all required materials, parts, equipment, labor, tools, and accessories.

1.3 SUMMARY

- A. This Section includes general administrative and procedural requirements for mechanical installations. The following administrative and procedural requirements are included.
 - 1. Codes & standards.
 - 2. Submittals.
 - 3. Quality control.
 - 4. Permits, fees, and inspections.
 - 5. Schedule and sequence.
 - 6. Project and site conditions.
 - 7. Delivery, storage, and handling.
 - 8. Coordination drawings.
 - 9. Record documents.
 - 10. Maintenance manuals.
 - 11. Warranties and guaranties.
 - 12. Rough-ins.
 - 13. Mechanical installations.
 - 14. Cutting and patching.
 - 15. Firestopping
 - 16. Mechanical identification.
- B. Related Sections: The following sections contain requirements that relate to this section:
 - 1. Division 2 through 14 all sections

2. Division 16 - all sections.

1.4 CODES AND STANDARDS

- A. Except as modified by governing codes, comply with applicable provisions and recommendations of the following:
1. ANSI Standards.
 2. Owner's Insurance Company.
 3. All applicable federal, state and local laws and statutes.

1.5 SUBMITTALS

- A. Shop Drawings:
1. Submit for review, detailed shop drawings of all the equipment and material required to complete the work. No material or equipment may be delivered to the jobsite or installed until accepted shop drawings for the particular material or equipment have been approved by the Owner or his authorized representative.
 2. Submit shop drawings in accordance with the requirements outlined in the General Conditions.
 3. Failure to submit shop drawings in ample time for checking will not entitle Contractor to Contract time, or increase in contract cost.

1.6 QUALITY ASSURANCE

- A. Drawings:
1. Drawings are diagrammatic. They indicate the general arrangement of systems and work included in the contract. Drawings are not to be scaled. Original architectural drawings and details shall be examined for exact location of fixtures and equipment. When drawing are not available or where they are not definitely located, this information shall be obtained from the Owner or authorized representative.
 2. Surveys and Measurements:
 - a. Before submitting bid, visit site, become familiar with conditions under which work will be installed. Contractor will be held responsible for assumptions, omissions, and errors made as a result of failure to become familiar with site and contract documents.
 - b. Base all measurements, both horizontal and vertical, from established benchmarks. All work shall agree with established lines and levels. Verify all measurements at site

and check the correctness of same.

- c. Notify the Engineer promptly of discrepancies between actual measurements and those indicated, which prevents following good practice or intent of drawings and specifications. Do not proceed with work until Contractor has received instructions from Engineer.

B. Labor:

1. Cooperation with Other Trades:

- a. Give full cooperation to other trades; furnish in writing to Contractor, with copies to the Owner, information necessary to permit the work of all trades to be installed satisfactorily and with the least possible interference or delay.
- b. Where work will be installed in close proximity to, or will interfere with work of other trades, assist in working out space conditions to make a satisfactory adjustment. If directed by the Owner, prepare composite working drawings and sections at a suitable scale not less than $1/4" = 1'0"$, clearly showing how work is to be installed in relation to the work of other trades. If work under this division is installed before coordinating with other trades, or to cause any interference with work of other trades, make necessary changes to correct the condition without additional cost.
- c. Furnish to other trades all necessary templates, patterns, setting plans, and shop details for the proper installation of work and for the purpose of coordinating adjacent work.

2. Materials & Workmanship:

- a. Materials and apparatus required for the work shall be new and of first class quality. Furnished, delivered, erected, connected and finished in every detail. Select and arrange to fit properly into the building spaces. Where no specific kind or quality of material is given, furnish first class standard article as accepted by Owner.
- b. Furnish the services of an experienced superintendent who shall be in constant charge of the work, together with skilled craftsmen and labor required to unload, transfer, erect, connect-up, adjust, start, operate, and test each system.

- c. All equipment and materials to be installed with the acceptance of the Owner or his authorized representative in accordance with the recommendations of the manufacturer. This includes the performance of such test as the manufacturer recommends.
3. Protection of Materials:
- a. Multiple Units: When two or more units of materials or equipment of the same type or class are required, these units shall be products of one manufacturer.
 - b. Welding: Before any welding is performed, submit a copy of the Welding Procedure Specification (WPS) together with the Procedure Qualification Record as required by Section IX of the ASME Boiler and Pressure Vessel Code.
 - 1. Before any welder performs any welding, submit a copy of the Manufacturer's Record of Welder or Welding Operator Qualification Tests as required by Section IX of the ASME Boiler and Pressure Vessel Code. The letter or symbol (as shown on the qualification test form) shall be used to identify the work of that welder and shall be affixed, in accordance with appropriate construction code, to each completed weld.
 - 2. The types and extent of non-destructive examinations required for pipe welds are shown in Table 136.4 of the Code for Pressure Piping, ASNI/ASME B31.1.
 - c. Manufacturer's Recommendations: Where installation procedures or any part thereof are required to be in accordance with the recommendations of the manufacturer of the material being installed, printed copies of these recommendations shall be furnished to the Engineer prior to the installation. Installation of the item will not be allowed to proceed until the recommendations are received. Failure to furnish these recommendations can be cause for rejection of the material.

1.7 PERMITS, FEES, & INSPECTIONS

- A. Give all necessary notices, obtain all permits, and pay all government sales taxes, fees, and other costs, including utility connections or extensions in connection with work. File necessary approvals of governmental departments having jurisdiction. Obtain required certificates

of inspection for work and deliver a copy to the Owner or his authorized representative before requesting acceptance for final payment.

1.8 SCHEDULE & SEQUENCE

A. Temporary Shutdowns:

1. Installation of new systems requiring the temporary shutdown of an existing operating system, the connection of the new system to be performed at such time as designated by the owner or authorized representative.
2. Notify the Owner of the estimated duration of the shutdown as noted elsewhere.
3. Arrange work for continuous performance, including authorized overtime if required, to assure existing operating services will be shut down only during the time actually required to make connections.

B. Temporary Services:

1. Refer to the General Conditions and Special Conditions for a full description of the temporary services to be provided.

C. Temporary Openings:

1. Ascertain from examination of the drawings any special temporary openings in the building required for the admission of apparatus provided under this Division. Notify the Owner accordingly. In the event of failure to give sufficient notice to the Contractor in time to arrange for openings during construction, assume all costs of providing such openings thereafter.

D. Sequencing:

1. Coordinate sequence of work with General Contractor.

1.9 PROJECT & SITE CONDITIONS

A. Cutting and Patching:

1. Furnish all cutting and patching. Furnish sketches showing the locations and sizes of openings, chases, etc., required for the installation of work. Furnish the Contractor with an approximation

of the number of openings, chases, etc., required.

B. Waterproofing:

1. Where a work pierces existing waterproofing, re-waterproof. The method of installation to be reviewed by Owner or his authorized representative before work is done. Furnish all sleeves, caulking, and flashing required to make openings watertight.

1.10 DELIVERY, STORAGE, & HANDLING

A. Delivery & Receipt:

1. Contractor is responsible for the delivery and storage of all materials, parts, equipment, etc. required for this project.

B. Storage:

1. The Contractor shall store all material, parts, and equipment required for this project in accordance with supplier's and manufacturer's recommendations, and Owner's requirements.

C. Handling, Hoisting, Rigging, & Scaffolding:

1. Furnish all scaffolding, rigging, hoisting, and services necessary for erection and delivery into the premises of any equipment and apparatus furnished under this Division. Remove same from premises when no longer required.

1.11 RECORD DOCUMENTS

- A. Maintain at the job site a record set of drawings on which any changes in location of equipment, piping, ducts, valves, cleanouts, panels, and major conduits shall be recorded. These shall be clearly marked on a clean set of prints at the completion of work for record drawings and turned over to the Owner.

1.12 OPERATION & MAINTENANCE MANUALS FOR MECHANICAL SYSTEMS

- A. Bind Operation & Maintenance Manual for Mechanical System in a hard-backed binder. Spine of each binder shall have the following lettering done in silkscreen:

OPERATION AND MAINTENANCE MANUAL
BATHROOM RENOVATIONS AT VARIOUS PARKS, CHESHIRE, CT

1. Provide a master index at beginning of Manual showing items included. Use plastic tab indexes for sections of Manual.
 2. First section shall consist of name, address, and phone number of Mechanical & Electrical Engineers, General Contractor and Mechanical, Plumbing, Sheet Metal, Refrigeration, Temperature Control & Electrical Contractors. Also include a complete list of equipment installed with name, address, and phone number of vendor.
 3. Provide section for each type of item of equipment.
 4. Submit three copies of Operation & Maintenance Manual to Engineer for his approval. Use one of these approved copies during final inspection and leave with building custodian.
- B. Include descriptive literature (Manufacturer's catalog data) of each manufactured item. Literature shall show capacities and size of equipment used and be marked indicating each specific item with applicable data underlined.
- C. Operating instructions shall include:
1. General description of each mechanical system.
 2. Step by step procedure to follow in putting each piece of mechanical equipment into operation.
 3. Provide schematic control diagrams for each separate fan system, cooling system, heating system, control panel, etc. Each diagram shall show locations of start-stop switches, insertion thermostats, room thermostats, thermometers, firestats, pressure gauges, automatic valves, and refrigeration accessories. Mark correct operating setting for each control instrument on these diagrams.
 4. Provide diagram for electrical control system showing wiring of related electrical control items such as firestats, fuses, interlock, electrical switches, and relays.
 5. Provide drawing of each temperature control panel identifying components on the panels and their functions.
- D. Maintenance instructions shall include:
1. Manufacturer's maintenance equipment installed in Project. Instructions shall include name of vendor, installation instructions, parts numbers & lists, operation instructions of equipment and maintenance & lubrication instructions.
 2. Summary list of mechanical equipment requiring lubrication

showing name of equipment, location and type, and frequency of lubrication.

3. List of mechanical equipment used indicating name, model, serial number, and name plate data of each item together with number and name associated with each system item.
4. List spare parts and quantities to be maintained in ready inventory at project site.

1.13 WARRANTIES AND GUARANTIES

- A. Guarantee all material and workmanship under this Division for a period of one year, (compressors five (5) years) from the date of final acceptance by the Owner.
- B. During guarantee period, all defects developing through materials and/or workmanship shall be replaced immediately without expense to the owner. Make such repairs or replacements to the satisfaction of the Owner.

PART 2 - PRODUCTS

2.1 ACCEPTABLE MANUFACTURERS

- A. As specified on drawings.

2.2 MATERIALS

- A. As specified on drawings.

2.3 EQUIPMENT DEVIATIONS

- A. Where the Contractor proposed to use an item of equipment other than that specified or detailed on the drawings which requires the redesign of the structure, partitions, foundations, piping, wiring or any other part of the mechanical, electrical or architectural layout, all such redesign, and all new drawings and detailing required therefore, shall be prepared at the Contractor's expense and are subject to the review and approval of the Owner or his authorized representative. Owner reserves the right to have the Architect or Engineer of his choice prepare any redesign work.
- B. Where such accepted deviation requires a different quantity and arrangement of ductwork, piping, wiring, conduit, and equipment from that specified or indicated on the drawings, the Contractor will provide ductwork, piping, structural supports, insulation, controllers, motors,

starters, electrical wiring and conduit, or other additional equipment required at no additional cost to the Owner.

- C. When equipment or methods deviate from original plans or specifications, the Contractor must submit a written request to deviate to the Engineer. At a minimum the request will address the following:

- equipment which is different than specified
- name and data related to the proposed deviation
- reason for deviation
- advantageous or disadvantageous to the Owner
- credit or increase in cost to the Owner
- guarantees or warranties offered (if any)
- acceptance of liability for equivalent performance.

2.4 MANUFACTURER'S IDENTIFICATION

- A. Attach manufacturer's nameplate, name, trademark and address permanently to equipment and material furnished under this Division. Nameplate of a Contractor or Distributor is not acceptable.

2.5 ELECTRICAL REQUIREMENTS

- A. Motors:

1. Electric motors furnished as a component part of equipment furnished under this Division shall conform to the requirements of IEEE, NEMA, UL, ANSI C50, and ANSI CI. Motors to be suitable for required load, duty voltage, phase, frequency, service and location.
2. Motors to be suitable for continuous duty at rated horsepower with temperature rise not to exceed 40°C for drip-proof motors, 50°C for splash-proof motors, and 55°C for totally enclosed motors. Motors to be capable of withstanding momentary overloads of 25 percent without injurious overheating.
3. Motors to have nameplates giving Manufacturer's name, serial number, horsepower, speed and current characteristics.
4. Motors smaller than 1 HP to be capacitor start or split-phase type designed for 120 volts, single phase, 60 cycles alternating current. Motors 1 HP and larger to be squirrel-cage induction or wound rotor, induction type, 3 phase, 60 cycles, alternating current.
5. Motor leads shall be permanently identified and supplied with

connectors.

6. Each motor to be selected for quiet operation in accordance with NEMA standards.

B. Motor Starters:

1. Electric motor starters shall conform to requirements of IEEE, NEMA, UL, ANSI, CI and shall be suitable for the required load, duty, voltage, phase, frequency, service, and location.
2. When interlocking or automatic control of single-phase motors is required, motors to be furnished with full voltage, across-the-line starters.

C. Connections:

1. Power wiring to be furnished and installed complete from power source to motor or equipment junction box, including power wiring through the starters. Starters not factory mounted on equipment shall be furnished and installed under Division 16.

2.6 MECHANICAL REQUIREMENTS

A. Bases & Supports:

1. Provide necessary foundations, supports, pads, bases and piers required for equipment, piping, motors, and other equipment furnished under this Division. Submit drawings to Owner for review before purchase, fabrication, or construction.
2. Construction of foundations, supports, pads, bases, and piers where mounted on the floor to be of the same materials and same quality of finish as the adjacent surrounding flooring material.
3. Securely attach equipment to building structure. Attachments that are, in the opinion of the Owner or his authorized representative deficient, will be replaced as directed.

B. Vibration Isolation:

1. Provide vibration isolation features and related installation in accordance with manufacturer requirements and engineer's recommendations.

C. Lubrication:

1. Lubricate all equipment having moving parts and requiring lubrication according to manufacturer's recommendations prior to testing and operation. Equipment discovered to have been operated before lubrication is subject to rejection and replacement at no cost to the Owner.

D. Accessibility:

1. Be responsible for the sufficiency of the size of shafts and chases, adequate clearance in double partitions and hung ceilings for proper installation of work. Cooperate with the Contractor and other contractors whose work is in the same space. Advise the Contractor of requirements. Such spaces and clearances shall be kept to the minimum size required.
2. Locate all equipment which requires servicing in fully accessible positions. Equipment shall include but not be limited to, valves, traps, clean-outs, motors, controllers, and drain points. If required for better accessibility furnish access doors for the purpose. Minor deviations from the drawings may be made to allow for better accessibility. Any change shall be submitted to the Owner or his authorized representative for review.

E. Connection to Existing Structures:

1. Before cutting, drilling, attaching, or any work involving building elements, coordinate work with others and Owner to avoid damage to building elements.

F. Quiet Operation:

1. Objectionable noise or vibration transmitted to occupied portions of the building by apparatus, piping, ducts, or other parts of the work to be remedied.

2.7 FIRESTOPPING

- A. Fire-stopping material shall be UL listed and tested silicone elastomer specifically formulated for use in horizontal and vertical applications shall possess intumescent characteristics; upon exposure to heat above 250 degrees F. shall expand to not less than five times its original volume to form a fireproof envelope UL rated for 2 and 3 hour protection, when applied in accordance with the manufacturer's recommendation.

PART 3 - EXECUTION

3.1 ROUGH-IN

- A. Verify final locations for rough-ins with field measurements and with the requirements of the actual equipment to be connected.
- B. Refer to equipment specifications in Divisions 2 through 16 for rough-in requirements.

3.2 MECHANICAL INSTALLATIONS

- A. General: Sequence, coordinate, and integrate the various elements of mechanical systems, materials, and equipment. Comply with the following requirements:
 - 1. Coordinate mechanical systems, equipment, and materials installation with other building components.
 - 2. Verify all dimensions by field measurements.
 - 3. Arrange for chases, slots, and openings in other building components during progress of construction, to allow for mechanical installations.
 - 4. Coordinate the installation of required supporting devices and sleeves to be set in poured-in-place concrete and other structural components, as they are constructed.
 - 5. Sequence, coordinate, and integrate installations of mechanical materials and equipment for efficient flow of the Work.
 - 6. Where mounting heights are not detailed or dimensioned, install systems, materials, and equipment to provide the maximum headroom possible.
 - 7. Coordinate connection of mechanical systems with exterior underground and overhead utilities and services. Comply with requirements of governing regulations, franchised service companies, and controlling agencies. Provide required connection for each service.
 - 8. Install systems, materials, and equipment to conform with approved submittal data, including coordination drawings, to greatest extent possible. Conform to arrangements indicated by the Contract Documents, recognizing that portions of the Work are shown only in

diagrammatic form. Where coordination requirements conflict with individual system requirements, refer conflict to the Engineer.

9. Install systems, materials, and equipment level and plumb, parallel and perpendicular to other building systems and components, where installed exposed in finished spaces.
10. Install mechanical equipment to facilitate servicing, maintenance, and repair or replacement of equipment components. As much as practical, connect equipment for ease of disconnecting, with minimum of interference with other installations. Extend grease fittings to an accessible location.
11. Install access panel or doors where units are concealed behind finished surfaces.
12. Install systems, materials, and equipment giving right-of-way priority to systems required to be installed at a specified slope.

3.3 CUTTING AND PATCHING

- A. General: Perform cutting and patching in accordance with, the following requirements:
 1. Protection of Installed Work: During cutting and patching operations, protect adjacent installations.
- B. Perform cutting, fitting, and patching of mechanical equipment and materials required to:
 1. Uncover Work to provide for installation of ill-timed Work.
 2. Remove and replace defective Work.
 3. Remove and replace Work not conforming to requirements of the Contract Documents.
 4. Remove samples of installed Work as specified for testing.
 5. Install equipment and materials in existing structures.
 6. Upon written instructions from the Engineer, uncover and restore Work to provide for Engineer observation of concealed Work.
- C. Cut, remove and legally dispose of selected mechanical equipment, components, and materials as indicated, including but not limited to removal of mechanical piping, heating units, plumbing fixtures and trim, and other mechanical items made obsolete by the new Work.
- D. Protect the structure, furnishings, finishes, and adjacent materials not indicated or scheduled to be removed.

- E. Provide and maintain temporary partitions or dust barriers adequate to prevent the spread of dust and dirt to adjacent areas.
 - 1. Patch existing finished surfaces and building components using new materials matching existing materials and experienced Installers. Installers' qualifications refer to the materials and methods required for the surface and building components being patched.
 - 2. Patch finished surfaces and building components using new materials specified for the original installation and experienced Installers. Installers' qualifications refer to the materials and methods required for the surface and building components being patched.

3.4 FIRE STOPPING

- A. Firestopping: Unused slots, sleeves and other penetrations in floor, walls or other general construction shall be closed and sealed with an approved firestopping material.
 - 1. Floor slots and openings shall be closed with 16 gage galvanized steel sheet supported on 1-inch by 1-inch by 1/8 inch structural angle drilled or supported with powder driven studs into the building structure. Firestop with a layer of silicone elastomer not less than 1-inch thick which completely fills the opening. The top surface of the silicone elastomer shall be approximately 1-inch below the finished floor slab.
 - 2. Openings in walls shall be closed with 16 gage galvanized steel sheet securely attached at the midpoint of the wall thickness and firestopped on both sides of steel sheet with not less than 1/8-inch thick layer of non-sagging silicone elastomer to fully cover the opening.
 - 3. Single or multiple pipes passing through walls and floors shall have the annular space between pipes or between pipes and structure filled with silicone elastomer to provide a 3-hour rated firestop for floors and walls.
- B. Pipe and ducts: The annulus between exposed pipe and ductwork and walls or floors in finished spaces shall be filled, sealed, and painted to match adjacent surfaces.

3.5 FIELD QUALITY CONTROL

- A. Perform field tests as specified under other sections.
- B. Arrange for local inspection authorities to inspect work performed prior to burial, closing-in behind wall and above ceiling or encase in concrete. Also arrange for final inspection of work and obtain Final Inspection Certificate before final inspection by Owner or his representative.

3.6 PAINTING

- A. See Division 9 for painting in finished areas.
- B. Materials shipped to the job site under this Division to have prime coat and standard manufacturer's finish.

3.7 EQUIPMENT IDENTIFICATION

- A. Equipment Identification:
 - 1. Identify air handling units, heaters, and condensing units with the following data engraved in white on black laminated plastic (2" x 3") and fastened to equipment with screws.
 - a. Equipment mark noted on Drawings (i.e., EF-1).
 - b. Area served.

3.8 CLEANING

- A. Thoroughly clean ducts and equipment of foreign substances before making operational.
- B. Any part of a system stopped by foreign matter after being placed in operation, to be disconnected, cleaned, and reconnected to locate and remove obstructions. Work damaged in the course of removing obstructions will be repaired or replaced at no additional cost to the Owner.
- C. Cap all ducts and pipes to protect against entrance of foreign matter.
- D. Remove rubbish, debris, and excess materials. Remove oil and grease stains on floor areas.

END OF SECTION 15010

SECTION 15050
BASIC MECHANICAL MATERIALS AND METHODS

PART 1 - GENERAL

1.1 RELATED DOCUMENTS

- A. Drawings and general provisions of Contract, including General Conditions apply to this Section.

1.2 SUMMARY

- A. This Section includes the following basic mechanical materials and methods to complement other Division 15 Sections.
 - 1. Piping materials and installation instructions common to most piping systems.
 - 2. Concrete equipment base construction requirements.
 - 3. Equipment nameplate data requirements.
 - 4. Nonshrink grout for equipment installations.
 - 5. Field-fabricated metal and wood equipment supports.
 - 6. Installation requirements common to equipment specification sections.
 - 7. Cutting and patching.
 - 8. Touch-up painting and finishing.
- B. Pipe and pipe fitting materials are specified in piping system Sections.

1.3 DEFINITIONS

- A. Pipe, pipe fittings, and piping include tube, tube fittings, and tubing.
- B. Finished Spaces: Spaces other than mechanical and electrical equipment rooms, furred spaces, pipe and duct shafts, unheated spaces immediately below the roof, spaces above ceilings, unexcavated spaces, crawl spaces, and tunnels.
- C. Exposed Interior Installations: Exposed to view indoors. Examples include finished occupied spaces and mechanical equipment rooms.
- D. Exposed Exterior Installations: Exposed to view outdoors, or subject to outdoor ambient temperatures and weather conditions. Examples include rooftop locations.

- E. Concealed Interior Installations: Concealed from view and protected from physical contact by building occupants. Examples include above ceilings and in duct shafts.
- F. Concealed Exterior Installations: Concealed from view and protected from weather conditions and physical contact by building occupants, but subject to outdoor ambient temperatures. Examples include installations within unheated shelters.

1.4 SUBMITTALS

- A. General: Submit the following in accordance with Conditions of Contract.
- B. Product data for following piping specialties:
 - 1. Mechanical sleeve seals.
 - 2. Identification materials and devices.
- C. Samples of color, lettering style, and other graphic representation required for each identification material and device.
- D. Shop drawings detailing fabrication and installation for metal and wood supports and anchorage for mechanical materials and equipment.
- E. Coordination drawings for access panel and door locations.
- F. Prepare coordination drawings to a 1/4 inch equals 1 foot scale or larger. Detail major elements, components, and systems of mechanical equipment and materials in relationship with other systems, installations, and building components. Show space requirements for installation and access. Show where sequence and coordination of installations are important to the efficient flow of the Work. Include the following:
 - 1. Proposed locations of piping, ductwork, equipment, and materials. Include the following:
 - a. Planned piping layout, including valve and specialty locations and valve stem movement.
 - b. Planned duct systems layout, including elbows radii and duct accessories.
 - c. Clearances for installing and maintaining insulation.
 - d. Clearances for servicing and maintaining equipment, including space for equipment disassembly required for periodic maintenance.
 - e. Equipment service connections and support details.
 - f. Exterior wall and foundation penetrations.
 - g. Fire-rated wall and floor penetrations.

- h. Sizes and location of required concrete pads and bases.
 - 2. Scheduling, sequencing, movement, and positioning of large equipment into the building during construction.
 - 3. Floor plans, elevations, and details to indicate penetrations in floors, walls, and ceilings and their relationship to other penetrations and installations.
 - 4. Reflected ceiling plans to coordinate and integrate installations, air outlets and inlets, light fixtures, communication systems components, sprinklers, and other ceiling-mounted items.
- G. Welder certificates signed by Contractor certifying that welders comply with requirements specified under "Quality Assurance" Article of this Section.

1.5. QUALITY ASSURANCE

- A. Qualify welding processes and operators for structural steel according to AWS D1.1 "Structural Welding Code - Steel."
- B. Qualify welding processes and operators for piping according to ASME "Boiler and Pressure Vessel Code," Section IX, "Welding and Brazing Qualifications."
 - 1. Comply with provisions of ASME B31 Series "Code for Pressure Piping."
 - 2. Certify that each welder has passed AWS qualification tests for the welding processes involved and that certification is current.
- C. ASME A13.1 for lettering size, length of color field, colors, and viewing angles of identification devices.
- D. Equipment Selection: Equipment of greater or larger power, dimensions, capacities, and ratings may be furnished provided such proposed equipment is approved in writing and connecting mechanical and electrical services, circuit breakers, conduit, motors, bases, and equipment spaces are increased. No additional costs will be approved for these increases, if larger equipment is approved. If minimum energy ratings or efficiencies of the equipment are specified, the equipment must meet the design requirements and commissioning requirements.

1.6 DELIVERY, STORAGE, AND HANDLING

- A. Deliver pipes and tubes with factory-applied end-caps. Maintain end-caps through shipping, storage, and handling to prevent pipe-end damage and prevent entrance of dirt, debris, and moisture.
- B. Protect stored pipes and tubes from moisture and dirt. Elevate above grade. When stored inside, do not exceed structural capacity of the floor.

- C. Protect flanges, fittings, and piping specialties from moisture and dirt.
- D. Store plastic pipes protected from direct sunlight. Support to prevent sagging and bending.

1.7 SEQUENCING AND SCHEDULING

- A. Coordinate mechanical equipment installation with other building components.
- B. Arrange for chases, slots, and openings in building structure during progress of construction, to allow for mechanical installations.
- C. Coordinate the installation of required supporting devices and set sleeves in poured-in-place concrete and other structural components, as they are constructed.
- D. Sequence, coordinate, and integrate installations of mechanical materials and equipment for efficient flow of the Work. Coordinate installation of large equipment requiring positioning prior to closing in the building.
- E. Coordinate connection of mechanical systems with exterior underground and overhead utilities and services. Comply with requirements of governing regulations, franchised service companies, and controlling agencies.
- F. Coordinate requirements for access panels and doors where mechanical items requiring access are concealed behind finished surfaces.
- G. Coordinate installation of identifying devices after completion of covering and painting, where devices are applied to surfaces. Install identifying devices prior to installation of acoustical ceilings and similar concealment.

PART 2 - PRODUCTS

2.1 PIPE AND PIPE FITTINGS

- A. Refer to individual piping system specification Sections for pipe and fitting materials and joining methods.
- B. Pipe Threads: ASME B1.20.1 for factory-threaded pipe and pipe fittings.

2.2 JOINING MATERIALS

- A. Refer to individual piping system specification Sections in Division 15 for special joining materials not listed below.
- B. Pipe Flange Gasket Materials: Suitable for the chemical and thermal conditions of the piping system contents.
 - 1. ASME B16.21, nonmetallic, flat, asbestos-free, 1/8-inch maximum thickness, except where thickness or specific material is indicated.
 - a. Full-Face Type: For flat-face, Class 125 cast-iron and cast-bronze flanges.
 - b. Narrow-Face Type: For raised-face, Class 250 cast-iron and steel flanges.
 - 2. ASME B16.20 for grooved, ring-joint, steel flanges.
 - 3. AWWA C110, rubber, flat face, 1/8-inch thick, except where other thickness is indicated; and full-face or ring type, except where type is indicated.
- C. Flange Bolts and Nuts: ASME B18.2.1, carbon steel, except where other material is indicated.
- D. Plastic Pipe Flange Gasket, Bolts, and Nuts: Type and material recommended by piping system manufacturer, except where other type or material is indicated.
- E. Solder Filler Metal: ASTM B 32.
 - 1. Alloy Sn95 or Alloy Sn94: Tin (approximately 95 percent) and silver (approximately 5 percent), having 0.10-percent lead content.
 - 2. Alloy Sn50: Tin (50 percent) and lead (50 percent).
 - 3. Alloy E: Tin (approximately 95 percent) and copper (approximately 5 percent), having 0.10-percent maximum lead content.
 - 4. Alloy HA: Tin-antimony-silver-copper-zinc, having 0.10-percent maximum lead content.
 - 5. Alloy HB: Tin-antimony-silver-copper-nickel, having 0.10-percent maximum lead content.
 - 6. Alloy Sb5: Tin (95 percent) and antimony (5 percent), having 0.20-percent maximum lead content.
- F. Brazing Filler Metals: AWS A5.8.
 - 1. BCuP Series: Copper-phosphorus alloys.
 - 2. BAg1: Silver alloy.

- G. Welding Filler Metals: Comply with AWS D10.12 for welding materials appropriate for wall thickness and chemical analysis of steel pipe being welded.
- H. Solvent Cements: Manufacturer's standard solvents complying with the following:
 - 1. Acrylonitrile-Butadiene-Styrene (ABS): ASTM D 2235.
 - 2. Chlorinated Poly(Vinyl Chloride) (CPVC): ASTM F 493.
 - 3. Poly(Vinyl Chloride) (PVC): ASTM D 2564.
 - 4. PVC to ABS Transition: Made to requirements of ASTM D 3138, color other than orange.
- I. Plastic Pipe Seals: ASTM F 477, elastomeric gasket.
- J. Flanged, Ductile-Iron Pipe Gasket, Bolts, and Nuts: AWWA C110, rubber gasket, carbon steel bolts and nuts.
- K. Couplings: Iron body sleeve assembly, fabricated to match outside diameters of plain-end, pressure pipes.
 - 1. Sleeve: ASTM A 126, Class B, gray iron.
 - 2. Followers: ASTM A 47, Grade 32510 or ASTM A 536 ductile iron.
 - 3. Gaskets: Rubber.
 - 4. Bolts and Nuts: AWWA C111.
 - 5. Finish: Enamel paint.

2.3 PIPING SPECIALTIES

- A. Escutcheons: Manufactured wall, ceiling, and floor plates; deep-pattern type, where required to conceal protruding fittings and sleeves.
 - 1. Inside Diameter: Closely fit around pipe, tube, and insulation of insulated piping.
 - 2. Outside Diameter: Completely cover opening.
 - 3. Cast Brass: One-piece, with set-screw.
 - a. Finish: Rough brass.
 - b. Finish: Polished chrome plate.
 - 4. Cast Brass: Split casting, with concealed hinge and set-screw.
 - a. Finish: Rough brass.
 - b. Finish: Polished chrome plate.
 - 5. Stamped Steel: One-piece, with set-screw and chrome plated finish.
 - 6. Stamped Steel: One-piece, with spring clips and chrome plated finish.

7. Stamped Steel: Split plate, with concealed hinge, set-screw, and chrome plated finish.
 8. Stamped Steel: Split plate, with concealed hinge, spring clips, and chrome plated finish.
 9. Stamped Steel: Split plate, with exposed-rivet hinge, set-screw, and chrome plated finish.
 10. Stamped Steel: Split plate, with exposed-rivet hinge, spring clips, and chrome plated finish.
 11. Cast-Iron Floor Plate: One-piece casting.
- B. Dielectric Fittings: Assembly or fitting having insulating material isolating joined dissimilar metals, to prevent galvanic action and stop corrosion.
1. Description: Combination of copper alloy and ferrous; threaded, solder, plain, and weld neck end types and matching piping system materials.
 2. Insulating Material: Suitable for system fluid, pressure, and temperature.
 3. Dielectric Unions: Factory-fabricated, union assembly, for 250 psig minimum working pressure at 180 deg F temperature.
 4. Dielectric Flanges: Factory-fabricated, companion-flange assembly, for 150 or 300 psig minimum pressure to suit system pressures.
 5. Dielectric-Flange Insulation Kits: Field-assembled, companion-flange assembly, full-face or ring type. Components include neoprene or phenolic gasket, phenolic or polyethylene bolt sleeves, phenolic washers, and steel backing washers.
 - a. Provide separate companion flanges and steel bolts and nuts for 150- or 300-psig minimum working pressure to suit system pressures.
 6. Dielectric Couplings: Galvanized-steel coupling, having inert and non-corrosive, thermoplastic lining, with threaded ends and 300 psig minimum working pressure at 225 deg F temperature.
 7. Dielectric Nipples: Electroplated steel nipple, having inert and non-corrosive, thermoplastic lining, with combination of plain, threaded, or grooved end types and 300 psig working pressure at 225 deg F temperature.
- C. Mechanical Sleeve Seals: Modular, watertight, mechanical type. Components include interlocking synthetic rubber links shaped to continuously fill annular space between pipe and sleeve. Connecting bolts and pressure plates cause rubber sealing elements to expand when tightened.
- D. Sleeves: The following materials are for wall, floor, slab, and roof penetrations:
1. Steel Sheet-Metal: 24 gage or heavier, galvanized sheet metal, round tube closed with welded longitudinal joint.

2. Steel Pipe: ASTM A 53, Type E, Grade A, Schedule 40, galvanized, plain ends.
3. Cast-Iron: Cast or fabricated "wall pipe" equivalent to ductile-iron pressure pipe, having plain ends and integral water stop, except where other features are specified.
4. Wall Penetration Systems: Wall sleeve assembly, consisting of housing, gaskets, and pipe sleeve, with 1 mechanical-joint end conforming to AWWA C110 and 1 plain pipe-sleeve end.
 - a. Penetrating Pipe Deflection: 5 percent without leakage.
 - b. Housing: Ductile-iron casting having waterstop and anchor ring, with ductile-iron gland, steel studs and nuts, and rubber gasket conforming to AWWA C111, of housing and gasket size as required to fit penetrating pipe.
 - c. Pipe Sleeve: AWWA C151, ductile-iron pipe.
 - d. Housing-to-Sleeve Gasket: Rubber or neoprene, push-on type, of manufacturer's design.
5. Cast-Iron Sleeve Fittings: Commercially-made, sleeve having integral clamping flange, with clamping ring, bolts, and nuts for membrane flashing.
 - a. Underdeck Clamp: Clamping ring with set-screws.
6. PVC Plastic: Manufactured, permanent, with nailing flange for attaching to wooden forms.
7. PE Plastic: Manufactured, reusable, tapered, cup-shaped, smooth outer surface, with nailing flange for attaching to wooden forms.

2.4 IDENTIFYING DEVICES AND LABELS

- A. General: Manufacturer's standard products of categories and types required for each application as referenced in other Division 15 Sections. Where more than single type is specified for listed application, selection is Installer's option, but provide single selection for each product category.
- B. Equipment Nameplates: Metal nameplate with operational data engraved or stamped; permanently fastened to equipment.
 1. Data: Manufacturer, product name, model number, serial number, capacity, operating and power characteristics, labels of tested compliances, and similar essential data.
 2. Location: An accessible and visible location.
- C. Stencils: Standard stencils, prepared for required applications with letter sizes conforming to recommendations of ASME A13.1 for piping and similar

applications, but not less than 1-1/4-inches-high letters for ductwork and not less than 3/4-inch-high letters for access door signs and similar operational instructions.

1. Material: Fiberboard.
 2. Material: Brass.
 3. Stencil Paint: Standard exterior type stenciling enamel; black, except as otherwise indicated; either brushing grade or pressurized spray-can form and grade.
 4. Identification Paint: Standard identification enamel of colors indicated or, if not otherwise indicated for piping systems, comply with ASME A13.1 for colors.
- D. Snap-On Plastic Pipe Markers: Manufacturer's standard pre-printed, semi-rigid snap-on, color-coded pipe markers, conforming to ASME A13.1.
- E. Pressure-Sensitive Pipe Markers: Manufacturer's standard pre-printed, permanent adhesive, color-coded, pressure-sensitive vinyl pipe markers, conforming to ASME A13.1.
- F. Engraved Plastic-Laminate Signs: ASTM D 709, Type I, cellulose, paper-base, phenolic-resin-laminate engraving stock; Grade ES-2, black surface, black phenolic core, with white (letter color) melamine subcore, except when other colors are indicated.
1. Fabricate in sizes required for message.
 2. Engraved with engraver's standard letter style, of sizes and with wording to match equipment identification.
 3. Punch for mechanical fastening.
 4. Thickness: 1/16 inch, except as otherwise indicated.
 5. Thickness: 1/8 inch, except as otherwise indicated.
 6. Thickness: 1/16 inch, for units up to 20 square inches or 8-inches long; 1/8 inch for larger units.
 7. Fasteners: Self-tapping stainless-steel screws or contact-type permanent adhesive.
- G. Plastic Equipment Markers: Laminated-plastic, color-coded equipment markers. Conform to following color code:
1. Yellow: Heating equipment and components.
 2. Brown: Energy reclamation equipment and components.
 3. Blue: Equipment and components that do not meet any of above criteria.
 4. For hazardous equipment, use colors and designs recommended by ASME A13.1.

5. Nomenclature: Include following, matching terminology on schedules as closely as possible:
 - a. Name and plan number.
 - b. Equipment service.
 - c. Design capacity.
 - d. Other design parameters such as pressure drop, entering and leaving conditions, and rpm.
 6. Size: Approximate 2-1/2 by 4 inches for control devices, dampers, and valves; and 4-1/2 by 6 inches for equipment.
- H. Lettering and Graphics: Coordinate names, abbreviations, and other designations used in mechanical identification, with corresponding designations indicated. Use numbers, lettering, and wording indicated for proper identification and operation/maintenance of mechanical systems and equipment.
1. Multiple Systems: Where multiple systems of same generic name are indicated, provide identification that indicates individual system number as well as service such as "Boiler No. 3," "Air Supply No. 1H," or "Standpipe F12."

2.5 GROUT

- A. Nonshrink, Nonmetallic Grout: ASTM C 1107, Grade B.
1. Characteristics: Post-hardening, volume-adjusting, dry, hydraulic-cement grout, nonstaining, noncorrosive, nongaseous, and recommended for interior and exterior applications.
 2. Design Mix: 5000 psi, 28-day compressive strength.
 3. Packaging: Premixed and factory-packaged.

PART 3 - EXECUTION

3.1 PIPING SYSTEMS - COMMON REQUIREMENTS

- A. General: Install piping as described below, except where system Sections specify otherwise. Individual piping system specification Sections in Division 15 specify piping installation requirements unique to the piping system.
- B. General Locations and Arrangements: Drawings (plans, schematics, and diagrams) indicate general location and arrangement of piping systems. Install piping as indicated, except where deviations to layout are approved on coordination drawings.

- C. Install piping at indicated slope.
- D. Install components having pressure rating equal to or greater than system operating pressure.
- E. Install piping free of sags and bends.
- F. Install exposed interior and exterior piping at right angles or parallel to building walls. Diagonal runs are prohibited, except where indicated.
- G. Install piping tight to slabs, beams, joists, columns, walls, and other building elements. Allow sufficient space above removable ceiling panels to allow for ceiling panel removal.
- H. Install piping to allow application of insulation plus 1-inch clearance around insulation.
- I. Locate groups of pipes parallel to each other, spaced to permit valve servicing.
- J. Install fittings for changes in direction and branch connections.
- K. Install couplings according to manufacturer's printed instructions.
- L. Install pipe escutcheons for pipe penetrations of concrete and masonry walls, wall board partitions, and suspended ceilings according to the following:
 - 1. Chrome-Plated Piping: Cast-brass, one-piece, with set-screw, and polished chrome-plated finish. Use split-casting escutcheons where required, for existing piping.
 - 2. Uninsulated Piping Wall Escutcheons: Cast-brass or stamped-steel, with set-screw.
 - 3. Uninsulated Piping Floor Plates in Utility Areas: Cast-iron floor plates.
 - 4. Insulated Piping: Cast-brass or stamped-steel, with concealed hinge, spring clips, and chrome-plated finish.
 - 5. Piping in Utility Areas: Cast-brass or stamped-steel, with set-screw or spring clips.
- M. Sleeves are not required for core drilled holes.
- N. Permanent sleeves are not required for holes formed by PE plastic (removable) sleeves.
- O. Install sleeves for pipes passing through concrete and masonry walls, concrete floor and roof slabs, and where indicated.

- P. Install sleeves for pipes passing through concrete and masonry walls, gypsum-board partitions, concrete floor and roof slabs, and where indicated.
1. Cut sleeves to length for mounting flush with both surfaces.
 - a. Exception: Extend sleeves installed in floors of mechanical equipment areas or other wet areas 2 inches above finished floor level. Extend cast-iron sleeve fittings below floor slab as required to secure clamping ring where specified.
 2. Build sleeves into new walls and slabs as work progresses.
 3. Install large enough sleeves to provide 1/4-inch annular clear space between sleeve and pipe or pipe insulation. Use the following sleeve materials:
 - a. PVC Pipe Sleeves: For pipes smaller than 6 inches.
 - b. Steel Pipe Sleeves: For pipes smaller than 6 inches.
 - c. Steel Sheet-Metal Sleeves: For pipes 6 inches and larger, penetrating gypsum-board partitions.
 - d. Cast-Iron Sleeve Fittings: For floors having membrane waterproofing. Secure flashing between clamping flanges. Install section of cast-iron soil pipe to extend sleeve to 2 inches above finished floor level. Flashing is specified in Division 16 Section "Basic Electrical Materials and Methods."
 - e. Seal space outside of sleeve fittings with nonshrink, nonmetallic grout.
 4. Except for below-grade wall penetrations, seal annular space between sleeve and pipe or pipe insulation, using elastomeric joint sealants specified in Division 7 Section "Joint Sealants."
- Q. Above Grade, Exterior Wall, Pipe Penetrations: Seal penetrations using sleeves and mechanical sleeve seals. Size sleeve for 1-inch annular clear space between pipe and sleeve for installation of mechanical seals.
1. Install steel pipe for sleeves smaller than 6 inches.
 2. Install cast-iron "wall pipes" for sleeves 6 inches and larger.
 3. Assemble and install mechanical seals according to manufacturer's printed instructions.
- R. Below Grade, Exterior Wall, Pipe Penetrations: Install cast-iron "wall pipes" for sleeves. Seal pipe penetrations using mechanical sleeve seals. Size sleeve for 1-inch annular clear space between pipe and sleeve for installation of mechanical seals.

- S. Below Grade, Exterior Wall, Pipe Penetrations: Install ductile-iron wall penetration system sleeves according to manufacturer's printed installation instructions.
- T. Fire Barrier Penetrations: Maintain indicated fire rating of walls, partitions, ceilings, and floors at pipe penetrations. Seal pipe penetrations with firestopping sealant material.
- U. Verify final equipment locations for roughing-in.
- V. Refer to equipment specifications in other Sections of these Specifications for roughing-in requirements.
- W. Piping Joint Construction: Join pipe and fittings as follows and as specifically required in individual piping system specification Sections.
 - 1. Ream ends of pipes and tubes and remove burrs. Bevel plain ends of steel pipe.
 - 2. Remove scale, slag, dirt, and debris from inside and outside of pipe and fittings before assembly.
 - 3. Soldered Joints: Construct joints according to AWS "Soldering Manual," Chapter 22 "The Soldering of Pipe and Tube."
 - 4. Brazed Joints: Construct joints according to AWS "Brazing Manual," Chapter 28 "Pipe and Tube."
 - 5. Threaded Joints: Thread pipe with tapered pipe threads according to ASME B1.20.1. Cut threads full and clean using sharp dies. Ream threaded pipe ends to remove burrs and restore full inside diameter. Join pipe fittings and valves as follows:
 - a. Note the internal length of threads in fittings or valve ends, and proximity of internal seat or wall, to determine how far pipe should be threaded into joint.
 - b. Apply appropriate tape or thread compound to external pipe threads (except where dry seal threading is specified).
 - c. Align threads at point of assembly.
 - d. Tighten joint with wrench. Apply wrench to valve end into which pipe is being threaded.
 - e. Damaged Threads: Do not use pipe or pipe fittings having threads that are corroded or damaged. Do not use pipe sections that have cracked or open welds.
 - 6. Welded Joints: Construct joints according to AWS D10.12 "Recommended Practices and Procedures for Welding Low Carbon Steel Pipe" using qualified processes and welding operators according to "Quality Assurance" Article.

7. Flanged Joints: Align flange surfaces parallel. Select appropriate gasket material, size, type, and thickness for service application. Install gasket concentrically positioned. Assemble joints by sequencing bolt tightening to make initial contact of flanges and gaskets as flat and parallel as possible. Use suitable lubricants on bolt threads. Tighten bolts gradually and uniformly using torque wrench.
8. Plastic Pipe and Fitting Solvent-Cement Joints: Clean and dry joining surfaces by wiping with clean cloth or paper towels. Join pipe and fittings according to the following standards:
 - a. Comply with ASTM F 402 for safe handling practice of solvent-cement and primers.
 - b. Acrylonitrile-Butadiene-Styrene (ABS): ASTM D 2235 and ASTM D 2661.
 - c. Chlorinated Poly(Vinyl Chloride) (CPVC): ASTM D 2846 and ASTM F 493.
 - d. Poly(Vinyl Chloride) (PVC) Pressure Application: ASTM D 2672.
 - e. Poly(Vinyl Chloride) (PVC) Non-Pressure Application: ASTM D 2855.
 - f. PVC to ABS (Non-Pressure) Transition: Procedure and solvent cement described in ASTM D 3138.
9. Plastic Pipe and Fitting Heat-Fusion Joints: Prepare pipe and fittings and join with heat-fusion equipment, according to manufacturer's printed instructions.
 - a. Plain-End Pipe and Fittings: Butt joining.
 - b. Plain-End Pipe and Socket-Type Fittings: Socket-joining.
- X. Piping Connections: Except as otherwise indicated make piping connections as specified below.
 1. Install unions, in piping 2 inches and smaller, adjacent to each valve and at final connection to each piece of equipment having 2-inches or smaller threaded pipe connection.
 2. Install flanges, in piping 2-1/2-inches and larger, adjacent to flanged valves and at final connection to each piece of equipment having flanged pipe connection.
 3. Dry Piping Systems (Gas, Compressed Air, and Vacuum): Install dielectric unions and flanges to connect piping materials of dissimilar metals.
 4. Wet Piping Systems (Water and Steam): Install dielectric coupling and nipple fittings to connect piping materials of dissimilar metals.

3.2 EQUIPMENT INSTALLATION - COMMON REQUIREMENTS

- A. Install equipment to provide the maximum possible headroom, where mounting heights are not indicated.
- B. Install equipment according to approved submittal data. Portions of the Work are shown only in diagrammatic form. Refer conflicts to the Engineer.
- C. Install equipment level and plumb, parallel and perpendicular to other building systems and components in exposed interior spaces, except where otherwise indicated.
- D. Install mechanical equipment to facilitate servicing, maintenance, and repair or replacement of equipment components. Connect equipment for ease of disconnecting, with minimum of interference with other installations. Extend grease fittings to an accessible location.
- E. Install equipment giving right-of-way to piping systems installed at a required slope.

3.3 LABELING AND IDENTIFYING

- A. Piping Systems: Install pipe markers on each system. Include arrows showing normal direction of flow.
 - 1. Stenciled Markers: Complying with ASME A13.1.
 - 2. Plastic markers, with application systems. Install on pipe insulation segment where required for hot non-insulated pipes.
 - 3. Locate pipe markers as follows wherever piping is exposed in finished spaces, machine rooms, accessible maintenance spaces (shafts, tunnels, plenums) and exterior non-concealed locations.
 - a. Near each valve and control device.
 - b. Near each branch, excluding short take-offs for fixtures and terminal units. Mark each pipe at branch, where flow pattern is not obvious.
 - c. Near locations where pipes pass through walls, floors, ceilings, or enter non-accessible enclosures.
 - d. At access doors, manholes, and similar access points that permit view of concealed piping.
 - e. Near major equipment items and other points of origination and termination.
 - f. Spaced at a maximum of 50 feet intervals along each run. Reduce intervals to 25 feet in congested areas of piping and equipment.

- g. On piping above removable acoustical ceilings, except omit intermediately spaced markers.
- B. Equipment: Install engraved plastic laminate sign or equipment marker on or near each major item of mechanical equipment.
 - 1. Lettering Size: Minimum 1/4-inch-high lettering for name of unit where viewing distance is less than 2 feet, 1/2-inch-high for distances up to 6 feet, and proportionately larger lettering for greater distances. Provide secondary lettering 2/3 to 3/4 of size of principal lettering.
 - 2. Text of Signs: Provide text to distinguish between multiple units, inform operator of operational requirements, indicate safety and emergency precautions, and warn of hazards and improper operations, in addition to name of identified unit.
- C. Duct Systems: Identify air supply, return, exhaust, intake, and relief ducts with duct markers; or provide stenciled signs and arrows, showing duct system service and direction of flow.
 - 1. Location: In each space where ducts are exposed or concealed by removable ceiling system, locate signs near points where ducts enter into space and at maximum intervals of 50 feet.
- D. Adjusting: Relocate identifying devices which become visually blocked by work of this Division or other Divisions.

3.4 PAINTING AND FINISHING

- A. Damage and Touch-Up: Repair marred and damaged factory painted finishes with materials and procedures to match original factory finish.

3.5 CONCRETE BASES

- A. Construct concrete equipment bases of dimensions indicated, but not less than 6 inches larger in both directions than supported unit. Follow supported equipment manufacturer's setting templates for anchor bolt and tie locations. Use 3500 psi, 28-day compressive strength concrete and reinforcement.

3.6 ERECTION OF METAL SUPPORTS AND ANCHORAGE

- A. Cut, fit, and place miscellaneous metal supports accurately in location, alignment, and elevation to support and anchor mechanical materials and equipment.
- B. Field Welding: Comply with AWS D1.1 "Structural Welding Code - Steel."

3.7 ERECTION OF WOOD SUPPORTS AND ANCHORAGE

- A. Cut, fit, and place wood grounds, nailers, blocking, and anchorage to support and anchor mechanical materials and equipment.
- B. Select fastener sizes that will not penetrate members where opposite side will be exposed to view or will receive finish materials. Make tight connections between members. Install fasteners without splitting wood members.
- C. Attach to substrates as required to support applied loads.

3.8 CUTTING AND PATCHING

- A. Cut, channel, chase, and drill floors, walls, partitions, ceilings, and other surfaces necessary for mechanical installations. Perform cutting by skilled mechanics of the trades involved.
- B. Repair cut surfaces to match adjacent surfaces.

END OF SECTION 15050

SECTION 15100
VALVES

PART 1 - GENERAL

1.1 RELATED DOCUMENTS

- A. Drawings and general provisions of Contract, including General and Supplementary Conditions and Division 1 Specification sections, apply to this section.
- B. Requirements of the following Division 15 Sections apply to this section:
 - 1. "Basic Mechanical Requirements."
 - 2. "Basic Mechanical Materials and Methods."

1.2 SUMMARY

- A. This Section includes general duty valves common to most mechanical piping systems.
 - 1. Special purpose valves are specified in individual piping system specifications.

1.3 SUBMITTALS

- A. General: Submit the following in accordance with Conditions of Contract and Division 1 Specification Sections.
- B. Product data, including body material, valve design, pressure and temperature classification, end connection details, seating materials, trim material and arrangement, dimensions and required clearances, and installation instructions.

1.4 QUALITY ASSURANCE

- A. Single Source Responsibility: Comply with the requirements specified in Division 1 Section "MATERIALS AND EQUIPMENT."
- B. American Society of Mechanical Engineers (ASME) Compliance: Comply with ASME B31.9 for building services piping and ASME B31.1 for power piping.

- C. Manufacturers Standardization Society of the Valve and Fittings Industry (MSS) Compliance: Comply with the various MSS Standard Practices referenced.

1.5 DELIVERY, STORAGE, AND HANDLING

- A. Preparation For Transport: Prepare valves for shipping as follows:
 - 1. Ensure valves are dry and internally protected against rust and corrosion.
 - 2. Protect valve ends against damage to threads, flange faces, and weld-end preps.
 - 3. Set valves in best position for handling. Set globe and gate valves closed to prevent rattling; set ball and plug valves open to minimize exposure of functional surfaces; set butterfly valves closed or slightly open; and block swing check valves in either closed or open position.
- B. Storage: Use the following precautions during storage:
 - 1. Do not remove valve end protectors unless necessary for inspection; then reinstall for storage.
 - 2. Protect valves from weather. Store valves indoors. Maintain valve temperature higher than the ambient dew point temperature. If outdoor storage is necessary, support valves off the ground or pavement in watertight enclosures.

PART 2 - PRODUCTS

2.1 MANUFACTURERS

- A. Available Manufacturers:
 - 1. Engineer approved equal

2.2 VALVE FEATURES, GENERAL

- A. Valve Design: Rising stem or rising outside screw and yoke stems as indicated.
 - 1. Nonrising stem valves may be used where indicated.
- B. Pressure and Temperature Ratings: As required to suit system pressures and temperatures.
- C. Sizes: Same size as upstream pipe, unless otherwise indicated.

- D. Operators: Provide the following special operator features:
 - 1. Handwheels, fastened to valve stem, for valves other than quarter turn.
 - 2. Lever handles, on quarter-turn valves 6-inch and smaller, except for plug valves.
- E. Extended Stems: Where insulation is indicated or specified, provide extended stems arranged to receive insulation.
- F. Bypass and Drain Connections: Comply with MSS SP-45 bypass and drain connections.
- G. End Connections: As indicated in the valve specifications.
 - 1. Threads: Comply with ANSI B1.20.1.
 - 2. Flanges: Comply with ANSI B16.1 for cast iron, ANSI B16.5 for steel, and ANSI B16.24 for bronze valves.
 - 3. Solder-Joint: Comply with ANSI B16.18.
 - a. Caution: Where soldered end connections are used, use solder having a melting point below 840 deg F for gate, globe, and check valves; below 421 deg F for ball valves.

2.3 GATE VALVES

- A. Gate Valves, 2-Inch and Smaller: MSS SP-80; Class 125, body and bonnet of ASTM B 62 cast bronze; with threaded or solder ends, solid disc, copper-silicon alloy stem, brass packing gland, "Teflon" impregnated packing, and malleable iron handwheel. Provide Class 150 valves meeting the above where system pressure requires.
- B. Gate Valves, 2-1/2-Inch and Larger: MSS SP-70; Class 125 iron body, bronze mounted, with body and bonnet conforming to ASTM A 126 Class B; with flanged ends, "Teflon" impregnated packing, and two-piece backing gland assembly.

2.4 BALL VALVES

- A. Ball Valves, 1 Inch and Smaller: Rated for 150 psi saturated steam pressure, 400 psi WOG pressure; two-piece construction; with bronze body conforming to ASTM B 62, standard (or regular) port, chrome-plated brass ball, replaceable "Teflon" or "TFE" seats and seals, blowout-proof stem, and vinyl-covered steel handle. Provide solder ends for domestic hot and cold water service; threaded ends for heating hot water.

- B. Ball Valves, 1-1/4-Inch to 2-Inch: Rated for 150 psi saturated steam pressure, 400 psi WOG pressure; 3-piece construction; with bronze body conforming to ASTM B 62, conventional port, chrome-plated brass ball, replaceable "Teflon" or "TFE" seats and seals, blowout proof stem, and vinyl-covered steel handle. Provide solder ends for domestic hot and cold water service; threaded ends for heating hot water.

2.5 PLUG VALVES

- A. Plug Valves, 2-Inch and Smaller: Rated at 150 psi WOG; bronze body, with straightaway pattern, square head, and threaded ends.
- B. Plug Valves, 2-1/2-Inch and Larger: MSS SP-78; rated at 175 psi WOG; lubricated plug type, with semisteel body, single gland, wrench operated, and flanged ends.

2.6 GLOBE VALVES

- A. Globe Valves, 2-Inch and Smaller: MSS SP-80; Class 125; body and screwed bonnet of ASTM B 62 cast bronze; with threaded or solder ends, brass or replaceable composition disc, copper-silicon alloy stem, brass packing gland, "Teflon" impregnated packing, and malleable iron handwheel. Provide Class 150 valves meeting the above where system pressure requires.
- B. Globe Valves, 2-1/2-Inch and Larger: MSS SP-85; Class 125 iron body and bolted bonnet conforming to ASTM A 126, Class B; with outside screw and yoke, bronze mounted, flanged ends, and "Teflon" impregnated packing, and two-piece backing gland assembly.

2.7 BUTTERFLY VALVES

- A. Butterfly Valves, 2-1/2-Inch and Larger: MSS SP-67; rated at 200 psi; cast-iron body conforming to ASTM A 126, Class B. Provide valves with field replaceable EPDM sleeve, nickel-plated ductile iron disc (except aluminum bronze disc for valves installed in condenser water piping), stainless steel stem, and EPDM O-ring stem seals. Provide lever operators with locks.

2.8 CHECK VALVES

- A. Swing Check Valves, 2-Inch and Smaller: MSS SP-80; Class 125, cast-bronze body and cap conforming to ASTM B 62; with horizontal swing, Y-pattern, and bronze disc; and having threaded or solder ends. Provide valves capable of being reground while the valve remains in the line. Provide Class 150 valves meeting the above specifications, with threaded end

connections, where system pressure requires or where Class 125 valves are not available.

- B. Swing Check Valves, 2-1/2-Inch and Larger: MSS SP-71; Class 125 cast iron body and bolted cap conforming to ASTM A 126, Class B; horizontal swing, and bronze disc or cast-iron disc with bronze disc ring; and flanged ends. Provide valves capable of being refitted while the valve remains in the line.

PART 3 - EXECUTION

3.1 EXAMINATION

- A. Examine valve interior through the end ports for cleanliness, freedom from foreign matter, and corrosion. Remove special packing materials, such as blocks used to prevent disc movement during shipping and handling.
- B. Actuate valve through an open-close and close-open cycle. Examine functionally significant features, such as guides and seats made accessible by such actuation. Following examination, return the valve closure member to the shipping position.
- C. Examine threads on both the valve and the mating pipe for form (i.e., out-of-round or local indentation) and cleanliness.
- D. Examine mating flange faces for conditions that might cause leakage. Check bolting for proper size, length, and material. Check gasket material for proper size, material composition suitable for service, and freedom from defects and damage.
- E. Prior to valve installation, examine the piping for cleanliness, freedom from foreign materials, and proper alignment.
- F. Replace defective valves with new valves.

3.2 VALVE ENDS SELECTION

- A. Select valves with the following ends or types of pipe/tube connections:
 - 1. Copper Tube Size, 2-Inch and Smaller: Solder ends, except provide threaded ends for heating hot water and low-pressure steam service.
 - 2. Steel Pipe Sizes, 2-Inch and Smaller: threaded ends.
 - 3. Steel Pipe Sizes 2-1/2 Inch and Larger: flanged ends.

3.3 VALVE INSTALLATIONS

- A. General Application: Use gate, ball, and butterfly valves as indicated.
- B. Locate valves for easy access and provide separate support where necessary.
- C. Install valves and unions for each fixture and item of equipment arranged to allow equipment removal without system shutdown. Unions are not required on flanged devices.
- D. Install valves in horizontal piping with stem at the center of the pipe.
- E. Install valves in a position to allow full stem movement.
- F. Installation of Check Valves: Install for proper direction of flow as follows:
 - 1. Swing Check Valves: Horizontal position with hinge pin level.

3.4 SOLDER CONNECTIONS

- A. Cut tube square and to exact lengths.
- B. Clean end of tube to depth of valve socket with steel wool, sand cloth, or a steel wire brush to a bright finish. Clean valve socket in same manner.
- C. Apply proper soldering flux in an even coat to inside of valve socket and outside of tube.
- D. Open gate and globe valves to full open position.
- E. Remove the cap and disc holder of swing check valves having composition discs.
- F. Insert tube into valve socket, making sure the end rests against the shoulder inside valve. Rotate tube or valve slightly to ensure even distribution of the flux.
- G. Apply heat evenly to outside of valve around joint until solder will melt upon contact. Feed solder until it completely fills the joint around tube. Avoid hot spots or overheating valve. Once the solder starts cooling, remove excess amounts around the joint with a cloth or brush.

3.5 THREADED CONNECTIONS

- A. Note the internal length of threads in valve ends, and proximity of valve internal seat or wall, to determine how far pipe should be threaded into valve.

- B. Align threads at point of assembly.
- C. Apply appropriate tape or thread compound to the external pipe threads (except where dry seal threading is specified).
- D. Assemble joint, wrench tight. Wrench on valve shall be on the valve end into which the pipe is being threaded.

3.6 FLANGED CONNECTIONS

- A. Align flange surfaces parallel.
- B. Assemble joints by sequencing bolt tightening to make initial contact of flanges and gaskets as flat and parallel as possible. Use suitable lubricants on bolt threads. Tighten bolts gradually and uniformly with a torque wrench.
- C. For dead-end service, butterfly valves require flanges both upstream and downstream for proper shutoff and retention.

3.7 FIELD QUALITY CONTROL

- A. Tests: After piping systems have been tested and put into service, but before final adjusting and balancing, inspect valves for leaks. Adjust or replace packing to stop leaks; replace valves if leak persists.

3.8 ADJUSTING AND CLEANING

- A. Cleaning: Clean mill scale, grease, and protective coatings from exterior of valves and prepare valves to receive finish painting or insulation.

3.9 VALVE PRESSURE/TEMPERATURE CLASSIFICATION SCHEDULES

VALVES, 2-INCH AND SMALLER

SERVICE	GATE	GLOBE	BALL	CHECK
Domestic Hot and Cold Water	125	125	150	125
Heating Hot Water	150	150	150	150
Chilled Water	150	150	150	150

VALVES, 2-1/2-INCH AND LARGER

SERVICE	GATE	GLOBE	BUTTERFLY	CHECK
---------	------	-------	-----------	-------

Domestic Hot and Cold Water	125	125	200	125
Heating Hot Water	125	125	200	125
Chilled Water	125	125	200	125

END OF SECTION 15100

SECTION 15140
SUPPORTS AND ANCHORS

PART 1 - GENERAL

1.1 RELATED DOCUMENTS

- A. Drawing and general provisions of Contract, including General and Supplementary Conditions and Division 1 Specification Sections, apply to this Section.
- B. Requirements of the following Division 15 Sections apply to this section:
 - 1. "Basic Mechanical Requirements."
 - 2. "Basic Mechanical Materials and Methods."

1.2 SUMMARY

- A. This section includes the following:
 - 1. Horizontal-piping hangers and supports.
 - 2. Vertical-piping clamps.
 - 3. Hanger-rod attachments.
 - 4. Building attachments.
 - 5. Saddles and shields.
 - 6. Spring hangers and supports.
 - 7. Miscellaneous materials.
 - 8. Equipment supports.
- B. Related sections: The following sections contain requirements that relate to this section:
 - 1. Division 15 Section "Mechanical Insulation" for pipe insulation.

1.3 DEFINITIONS

- A. Terminology used in this section is defined in MSS SP-90.

1.4 SUBMITTALS

- A. General: Submit the following in accordance with conditions of contract and Division 1 specification sections.
 - 1. Product data, including installation instructions for each type of support and anchor. Submit pipe hanger and support schedule showing

Manufacturer's figure number, size, location, and features for each required pipe hanger and support.

2. Product certificates signed by the manufacturer of hangers and supports certifying that their products meet the specified requirements.
3. Assembly-type shop drawings for each type of support and anchor, indicating dimensions, weights, required clearances, and methods of assembly of components.

1.5 QUALITY ASSURANCE

- A. Qualify welding processes and welding operators in accordance with AWS D1.1 "Structural Welding Code - Steel."
 1. Certify that each welder has satisfactorily passed AWS qualification tests for welding processes involved and, if pertinent, has undergone recertification.
- B. Regulatory Requirements: Comply with applicable international plumbing code pertaining to product materials and installation of supports and anchors.

PART 2 - PRODUCTS

2.1 MANUFACTURED UNITS

- A. Hangers and support components shall be factory fabricated of materials, design, and manufacturer complying with MSS SP-58 and MSS SP-69.
 1. Pipe attachments shall have nonmetallic coating for electrolytic protection where attachments are in direct contact with copper tubing.

2.2 MISCELLANEOUS MATERIALS

- A. Steel Plates, Shapes, and Bars: ASTM A 36.

PART 3 - EXECUTION

3.1 EXAMINATION

- A. Examine substrates and conditions under which supports and anchors are to be installed. Do not proceed with installing until unsatisfactory conditions have been corrected.

3.2 INSTALLATION OF HANGERS AND SUPPORTS

- A. General: Install hangers, supports, clamps and attachments to support piping properly from building structure; comply with MSS SP-69 and SP-89. Install supports with maximum spacings complying with current local and international Plumbing and Mechanical Codes. Where piping of various sizes is supported together by trapeze hangers, space hangers for smallest pipe size or install intermediate supports for smaller diameter pipe as specified above for individual pipe hangers.
- B. Install building attachments within concrete or to structural steel. Space attachments within maximum piping span length indicated in MSS SP-69. Install additional attachments at concentrated loads, including valves, flanges, guides, strainers, expansion joints, and at changes in direction of piping.
- C. Install hangers and supports complete with necessary inserts, bolts, rods, nuts, washers, and other accessories.
- D. Install hangers and supports to allow controlled movement of piping systems, to permit freedom of movement between pipe anchors, and to facilitate action of expansion joints, expansion loops, expansion bends and similar units.
- E. Load Distribution: Install hangers and supports so that piping live and dead loading and stresses from movement will not be transmitted to connected equipment.
- F. Pipe Slopes: Install hangers and supports to provide indicated pipe slopes, and so that maximum pipe deflections allowed by ASME B31.9 Building Services Piping Code is not exceeded.
- G. Insulated Piping: Comply with the following installation requirements.
 - 1. Shields: Install protective shields MSS Type 40 on cold water piping that has vapor barrier. Shields shall span an arc of 180 degrees and shall have dimensions in inches not less than the following:

<u>NPS</u>	<u>LENGTH</u>	<u>THICKNESS</u>
1/4 THROUGH 3-1/2	12	0.048
4	12	0.060

- 2. Insert material shall be at least as long as the protective shield.

3. Thermal Hanger Shields: Install where indicated, with insulation of same thickness as piping.

3.3 METAL FABRICATION

- A. Cut, drill, and fit miscellaneous metal fabrications for pipe anchors and equipment supports. Install and align fabricated anchors in indicated locations.
- B. Fit exposed connections together to form hairline joints. Field weld connections that cannot be shop welded because of shipping size limitations.
- C. Field Welding: Comply with AWS D1.1 for procedures of manual shielded metal-arc welding, appearance and quality of welds made, methods used in correcting welding work, and the following:
 1. Use materials and methods that minimize distortion and develop strength and corrosion resistance of base metals.
 2. Obtain fusion without undercut or overlap.
 3. Remove welding flux immediately.
 4. Finish welds at exposed connections so that no roughness shows after finishing, and so that contours welded surfaces to match adjacent contours.

3.4 ADJUSTING

- A. Hanger Adjustment: Adjust hangers to distribute loads equally on attachments and to achieve indicated slope of pipe.

END OF SECTION - 15140

SECTION 15250
MECHANICAL INSULATION

PART 1 - GENERAL

1.1 RELATED DOCUMENTS

- A. Drawings and general provisions of Contract, including General and Supplementary Conditions and Division-1 Specification sections, apply to work of this section.
- B. Division-15 Basic Mechanical Materials and Methods sections apply to work of this section.

1.2 DESCRIPTION OF WORK

- A. Extent of mechanical insulation required by this section is indicated by requirements of this section.
- B. Types of mechanical insulation specified in this section include the following:
 - 1. Plumbing and Heating Piping Systems Insulation:
 - a. Fiberglass.
- C. Refer to Division-15 section "Supports and Anchors" for protection saddles, protection shields, and thermal hanger shields; not work of this section.

1.3 QUALITY ASSURANCE

- A. Manufacturer's Qualifications: Firms regularly engaged in manufacture of mechanical insulation products, of types and sizes required, whose products have been in satisfactory use in similar services for not less than 3 years.
- B. Installer's Qualifications: Firm with at least 5 years successful installation experience on projects with mechanical insulations similar to that required for this project.
- C. Flame/Smoke Ratings: Provide composite mechanical insulation (insulation, jackets, coverings, sealers, mastics and adhesives) with flame-spread index of 25 or less, and smoke-developed index of 50 or less, as tested by ASTM E 84 (NFPA 255) method.

1.4 SUBMITTALS

- A. Product Data: Submit manufacturer's technical product data and installation instructions for each type of mechanical insulation. Submit schedule showing manufacturer's product number, k-value, thickness, and furnished accessories for each mechanical system requiring insulation.
- B. Maintenance Data: Submit maintenance data and replacement material lists for each type of mechanical insulation. Include this data and product data in maintenance manual.

1.5 DELIVERY, STORAGE, AND HANDLING

- A. Deliver insulation, coverings, cements, adhesives, and coatings to site in containers with manufacturer's stamp or label, affixed showing fire hazard indexes of products.
- B. Protect insulation against dirt, water, and chemical and mechanical damage. Do not install damaged or wet insulation; remove from project site.

PART 2 - PRODUCTS

2.1 ACCEPTABLE MANUFACTURERS

- A. Available Manufacturers: Subject to compliance with requirements, manufacturers offering products which may be incorporated in the work include, but are not limited to, the following:
- B. Manufacturer: Subject to compliance with requirements, provide products of one of the following:
 - 1. Engineered approved equal.

2.2 PIPING INSULATION MATERIALS

- A. Fiberglass Piping Insulation: ASTM C 547, Class 1 unless otherwise indicated. K-factor maximum of 0.25 at 75 degrees F.
- B. Jackets for Piping Insulation: ASTM C 921, Type I (vapor barrier) for piping with temperatures below ambient, Type II for piping with temperatures above ambient.
 - 1. Encase pipe fittings insulation with one-piece premolded PVC fitting covers, fastened as per manufacturer's recommendations.
- C. Staples, Bands, Wires, and Cement: As recommended by insulation manufacturer for applications indicated.

- D. Adhesives, Sealers, and Protective Finishes: As recommended by insulation manufacturer for applications indicated.

2.3 DUCTWORK INSULATION MATERIALS:

- A. Rigid Fiberglass Ductwork Insulation: ASTM C 612, Class 1.
- B. Flexible Fiberglass Ductwork Insulation: ASTM C 553, Type I, Class B-4.
- C. Jackets for Ductwork Insulation: ASTM C 921, Type I.
- D. Ductwork Insulation Accessories: Provide staples, bands, wires, tape, anchors, corner angles and similar accessories as recommended by insulation manufacturer for applications indicated.
- E. Ductwork Insulation Compounds: Provide cements, adhesives, coatings, sealers, protective finishes and similar compounds as recommended by insulation manufacturer for applications indicated.

PART 3 - EXECUTION

3.1 INSPECTION

- A. Examine areas and conditions under which mechanical insulation is to be installed. Do not proceed with work until unsatisfactory conditions have been corrected in manner acceptable to Installer.

3.2 PLUMBING PIPING SYSTEM INSULATION

- A. Insulation Omitted: Omit insulation on chrome-plated exposed piping (except for handicapped fixtures), air chambers, unions, strainers, check valves, balance cocks, drainage piping buried piping, fire protection piping, and pre-insulated equipment.
- B. Domestic Cold Piping:
 - 1. Application Requirements: Insulate the following cold plumbing piping systems:
 - a. Domestic cold water piping.
 - b. Plumbing vents within 6 lineal feet of roof outlet.
 - c. Waste Piping.

2. Insulate each piping system specified above with one of the following types and thicknesses of insulation:
 - a. Fiberglass: thickness per IECC with vapor barrier.
- C. Domestic Hot Supply and Return Piping:
 1. Application Requirements: Insulate the following hot plumbing piping systems:
 - a. Domestic hot water supply and return recirculating piping.
 2. Insulate each piping system specified above with one of the following types and thicknesses of insulation:
 - a. Fiberglass: 1" thick for pipe sizes up to 1-1/4" and 1-1/2" thick for pipe sizes 1 1/2" to 4". Note: Provide thickness as required per most current IECC standards.

3.3 HVAC PIPING SYSTEM INSULATION

- A. A. Insulation Omitted: Omit insulation on hot piping within radiation enclosures or unit cabinets; on cold piping within unit cabinets provided piping is located over drain pan; on heating piping beyond control valve, located within heated space; on condensate piping between steam trap and union; and on unions, flanges, strainers, flexible connections, and expansion joints.
- B. Cold Piping (40 degrees F (4.4 degrees C) to ambient):
 1. Application Requirements: Insulate the following cold HVAC piping systems:
 - a. HVAC chilled water supply and return piping.
 - b. HVAC make-up water piping.
 - c. Air conditioner condensate drain piping.
 2. Insulate each piping system specified above with one of the following types and thicknesses of insulation:
 - a. Fiberglass: 1" thick for pipe sizes up to and including 4", 1-1/2" thick for pipe sizes over 4".
- C. Hot Low Pressure Piping (to 250 degrees F (121 degrees C)):
 1. Application Requirements: Insulate the following hot low pressure HVAC piping systems (steam piping up to 15 psi, water piping up to 250 degrees F (121 degrees C)).

- a. HVAC hot water supply and return piping.
 - b. Low pressure steam and condensate piping
 - c. Condenser water supply and return piping.
 - d. Heated fuel piping.
 - e. Hot gas refrigerant piping.
2. Insulate each piping system specified above with one of the following types and thicknesses of insulation:
- a. Fiberglass: 1" thick for pipe sizes up to and including 1", 1-1/2" thick for pipe sizes 1-1/2" through 4", 2" thick for pipe over 5".

3.4 INSTALLATION OF PIPING INSULATION

- A. General: Install insulation products in accordance with manufacturer's written instructions, and in accordance with recognized industry practices to ensure that insulation serves its intended purpose. All proposed piping shall be insulated.
- B. Install insulation materials with smooth and even surfaces. Insulate each continuous run of piping with full-length units of insulation, with a single cut piece to complete run. Do not use cut pieces or scraps abutting each other.
- C. Clean and dry pipe surfaces prior to insulating. Butt insulation joints firmly together to ensure a complete and tight fit over surfaces to be covered.
- D. Maintain integrity of vapor-barrier jackets on pipe insulation, and protect to prevent puncture or other damage.
- E. Cover valves, fittings and similar items in each piping system with equivalent thickness and composition of insulation as applied to adjoining pipe run. Install factory molded, precut or job fabricated units (at Installer's option) except where specific form or type is indicated.
- F. Extend piping insulation without interruption through walls, floors and similar piping penetrations, except where otherwise indicated.
- G. Butt pipe insulation against pipe hanger insulation inserts. For hot pipes, apply 3" wide vapor barrier tape or band over the butt joints. For cold piping apply wet coat of vapor barrier lap cement on butt joints and seal joints with 3" wide vapor barrier tape or band.

3.4 PROTECTION AND REPLACEMENT

- A. Replace damaged insulation which cannot be repaired satisfactorily, including units with vapor barrier damage and moisture saturated units.
- B. Protection: Insulation Installer shall advise Contractor of required protection for insulation work during remainder of construction period, to avoid damage and deterioration.

END OF SECTION 15250

SECTION 15411
WATER DISTRIBUTION PIPING

PART 1 - GENERAL

1.1 SUMMARY

- A. This Section includes domestic cold water and domestic hot water piping, fittings, and specialties within the building to a point 5 feet outside the building.

1.2 SUBMITTALS

- A. General: Submit the following in accordance with Conditions of Contract and Division 1 Specifications Sections.
 - 1. Product data for each pipe, piping specialty and valve specified.
 - 2. Test reports specified in Part 3 of this Section.
 - 3. Maintenance data for each piping specialty and valve specified for inclusion in Maintenance Manual.

1.3 DELIVERY, STORAGE, AND HANDLING

- A. Store pipe in a manner to prevent sagging and bending.

1.4 SEQUENCING AND SCHEDULING

- A. Coordinate the installation of pipe sleeves for foundation wall penetrations.

PART 2 - PRODUCTS

2.1 MANUFACTURERS

- A. Available Manufacturers: Subject to compliance with requirements, manufacturers offering products that may be incorporated in the Work include but are not limited to the following:
 - 1. Backflow Preventers:
 - a. Cla-Val Co.
 - b. Febco
 - c. Hersey Products, Inc.
 - d. Watts Regulator Co.
 - e. Zurn Industries Inc. Wilkins Regulator Div.

2.2 PIPE AND TUBE MATERIALS, GENERAL

- A. Copper Tube: ASTM B 88, Type L Water Tube, drawn temper.

- B. Copper Tube: ASTM B88, Type K, water tube drawn temper..

2.3 FITTINGS

- A. Wrought Copper Solder-Joint Fittings: ANSI B16.22, streamlined pattern.
- B. Wrought Copper and Bronze Grooved-End Fittings: ASTM B 75 Tube and ASTM B 584 Bronze Castings.
- C. Bronze Flanges: ANSI B16.24, Class 150, raised ground face, bolt holes spot faced.
- D. Unions: ASME B16.39, malleable iron, Class 150, hexagonal stock, with ball-and-socket joints, metal-to-metal bronze seating surfaces, female threaded ends. Threads shall conform to ASME B1.20.1.
- E. Dielectric Unions: Threaded, solder, or grooved-end connections as required to suit application; constructed to isolate dissimilar metals, prevent galvanic action, and prevent corrosion.

2.4 JOINING MATERIALS

- A. Solder Filler Metal: ASTM B 32, 95-5 Tin-Antimony.
- B. Brazing Filler Metals: AWS A5.8, BCuP Series.
- C. Gasket Material: Thickness, material, and type suitable for fluid to be handled and design temperatures and pressures.

2.5 GENERAL-DUTY VALVES

- A. General-duty valves (i.e., gate, globe, check, ball, and butterfly valves) are specified in Division 15 Section "Valves." Special duty valves are specified below by their generic name; refer to Part 3 Article "Valve Application" for specific uses and applications for each valve specified.

2.6 PIPING SPECIALTIES

- A. Vacuum Breakers: Hose connection vacuum breakers shall conform to ASSE Standard 1011, with finish to match hose connection.
- B. Relief Valves: Sizes for relief valves shall be in accordance with ASME Boiler and Pressure Vessel Codes for indicated capacity of the appliance for which installed.

1. Combined Pressure-Temperature Relief Valves: Bronze body, test lever, thermostat, complying with ANSI Z21.22 listing requirements for temperature discharge capacity. Temperature relief valves shall be factory set at 210 deg F, and pressure relief at 150 psi.

PART 3 - EXECUTION

3.1 EXAMINATION

- A. Examine rough-in requirements for plumbing fixtures and other equipment with water connections to verify actual locations of piping connections prior to installation.

3.2 PIPE APPLICATIONS

- A. Install Type L, drawn copper tube with wrought copper fittings and solder joints for pipe sizes 3 inches and smaller, above ground, within building.
- B. Install copper type K for pipe 2" and smaller, below ground, inside and outside building.

3.3 PIPING INSTALLATION

- A. General Locations and Arrangements: Drawings (plans, schematics, and diagrams) indicate the general location and arrangement of the piping systems. Location and arrangement of piping layout take into consideration pipe sizing and friction loss, expansion, pump sizing, and other design considerations. So far as practical, install piping as indicated.
- B. Use fittings for all changes in direction and branch connections.
- C. Install exposed piping at right angles or parallel to building walls. Diagonal runs are not permitted unless expressly indicated.
- D. Install piping free of sags or bends and with ample space between piping to permit proper insulation applications.
- E. Conceal all pipe installations in walls, pipe chases, utility spaces, above ceilings, below grade or floors, where feasible.
- F. Install piping tight to slabs, beams, joists, columns, walls, and other permanent elements of the building. Provide space to permit insulation applications, with 1-inch clearance outside the insulation.

- G. Locate groups of pipes parallel to each other, spaced to permit applying full insulation and servicing of valves.
- H. Install drains at low points in mains consisting of a tee fitting, 3/4-inch ball valve, and short 3/4-inch threaded nipple and cap.
- I. Exterior Wall Penetrations: Seal pipe penetrations through exterior walls with sleeves and mechanical sleeve seals. Pipe sleeves smaller than 6 inches shall be galvanized steel pipe; pipe sleeves 6 inches and larger shall be galvanized steel sheet metal.
- J. Fire Barrier Penetrations: Where pipes pass through fire-rated walls, partitions, ceilings, and floors, maintain the fire-rated integrity.
- K. Install piping level with no pitch.

3.4 HANGERS AND SUPPORTS

- A. General: Hanger, support, and anchor devices conforming to MSS SP-69 are specified in Division 15 Section "Supports and Anchors." Conform to the table below for maximum spacing of supports:
- B. Pipe Attachments: Install the following:
 - 1. Adjustable steel clevis hangers, MSS Type 1, for individual horizontal runs less than 20 feet in length.
- C. Install hangers for horizontal piping with the following maximum spacing and minimum rod sizes:

<u>Nom. Pipe Size - In.</u>	<u>Copper Tube Max. Span - Ft.</u>	<u>Min. Rod Dia. - In.</u>
Up to 3/4	6	3/8
1	6	3/8
1-1/4	6	3/8
1-1/2	10	3/8
2	10	3/8
2-1/2	10	1/2
3	10	1/2

- D. Support vertical copper tube at each floor.

3.5 PIPE AND TUBE JOINT CONSTRUCTION

- A. Soldered Joints: Comply with the procedures contained in the AWS "Soldering Manual."
- B. Brazed Joints: Comply with the procedures contained in the AWS "Brazing Manual."
 - 1. CAUTION: Remove stems, seats, and packing of valves and accessible internal parts of piping specialties before soldering and brazing.
 - 2. Fill the tubing and fittings during soldering and brazing with an inert gas (nitrogen or carbon dioxide) to prevent formation of scale.
 - 3. Heat joints to proper and uniform temperature.
- C. Threaded Joints: Conform to ASME B1.20.1, tapered pipe threads for field-cut threads. Join pipe fittings and valves as follows:
 - 1. Note the internal length of threads in fittings or valve ends, and proximity of internal seat or wall, to determine how far pipe should be threaded into joint.
 - 2. Align threads at point of assembly.
 - 3. Apply appropriate tape or thread compound to the external pipe threads (except where dry seal threading is specified).
 - 4. Assemble joint wrench tight. Wrench on valve shall be on the valve end into which the pipe is being threaded.
 - a. Damaged Threads: Do not use pipe with corroded or damaged threads. If a weld opens during cutting or threading operations, that portion of pipe shall not be used.
- D. Flanged Joints: Align flange surfaces parallel. Assemble joints by sequencing bolt tightening to make initial contact of flanges and gaskets as flat and parallel as possible. Use suitable lubricants on bolt threads. Tighten bolts gradually and uniformly with a torque wrench.
- E. Grooved-End Joints: Prepare pipe and tubing and install in accordance with manufacturer's installation instructions.
- F. Provide dielectric unions between pipes of dissimilar metals.

3.6 VALVE APPLICATIONS

- A. General-Duty Valve Applications: The Drawings indicate valve types to be used. Where specific valve types are not indicated, the following requirements apply:
 - 1. Shut-off duty: Use gate or ball valves.
 - 2. Throttling duty: Use globe or ball valves.

3.7 INSTALLATION OF VALVES

- A. Sectional Valves: Install sectional valves as indicated. For sectional valves 2 inches and smaller, use gate or ball valves; for sectional valves 2-1/2 inches and larger, use gate valves.
- B. Shutoff Valves: Install shutoff valves on inlet of each plumbing equipment item, on each supply to each plumbing fixture, and elsewhere as indicated. For shutoff valves 2 inches and smaller, use gate or ball valves; for shutoff valves 2-1/2 inches and larger, use gate valves.
- C. Drain Valves: Install drain valves on each plumbing equipment item, located to drain equipment completely for service or repair. Install at low points of horizontal runs, and elsewhere as required to drain distribution piping system completely. For drain valves 2 inches and smaller, use gate or ball valves; for drain valves 2-1/2 inches and larger, use gate valves.
- D. Check Valves: Install swing check valves on discharge side of each pump and elsewhere as indicated.
- E. Balance Cocks: Install in each hot water recirculating loop, discharge side of each pump, and elsewhere as indicated.

3.8 INSTALLATION OF PIPING SPECIALTIES

- A. Provide backflow preventers at each connection to mechanical equipment and systems and in compliance with the plumbing code and authority having jurisdiction. Locate in same room as equipment being connected.

3.9 EQUIPMENT CONNECTIONS

- A. Piping Runouts to Fixtures: Provide hot and cold water piping runouts to fixtures of sizes indicated, but in no case smaller than required by plumbing code.
- B. Mechanical Equipment Connections: Connect hot and cold water piping system to mechanical equipment as indicated. Provide shutoff valve and

union for each connection; provide drain valve on drain connection. For connections 2-1/2 inches and larger, use flanges instead of unions.

3.10 FIELD QUALITY CONTROL

A. Inspections: Inspect water distribution piping as follows:

1. Do not enclose, cover, or put into operation water distribution piping system until it has been inspected and approved by the authority having jurisdiction.
2. During the progress of the installation, notify the plumbing official having jurisdiction at least 24 hours prior to the time such inspection must be made. Perform tests specified below in the presence of the plumbing official.
 - a. Rough-in Inspection: Arrange for inspection of the piping system before concealed or closed in after system is roughed in and prior to setting fixtures.
 - b. Final Inspection: Arrange for a final inspection by the plumbing official to observe the tests specified below and to ensure compliance with the requirements of the plumbing code.
3. Reinspections: Whenever the plumbing official finds that the piping system will not pass the test or inspection, make the required corrections and arrange for reinspection by the plumbing official.
4. Reports: Prepare inspection reports signed by the plumbing official.

B. Test water distribution piping as follows:

1. Test for leaks and defects all new water distribution piping systems and parts of existing systems that have been altered, extended or repaired. If testing is performed in segments, submit a separate report for each test, complete with a diagram of the portion of the system tested.
2. Leave uncovered and unconcealed all new, altered, extended, or replaced water distribution piping until it has been tested and approved. Expose all such work for testing that has been covered or concealed before it has been tested and approved.
3. Cap and subject the piping system to a static water pressure of 110 psig without exceeding the pressure rating of the piping system materials. Isolate the test source and allow to stand for 4 hours. Leaks and loss in test pressure constitute defects that must be repaired.

4. Repair all leaks and defects with new materials and retest system or portion thereof until satisfactory results are obtained.
5. Prepare reports for all tests and required corrective action.

3.11 ADJUSTING AND CLEANING

- A. Balance recirculating hot water systems so that hot water is recirculated in all areas of the loop.
- B. Clean and disinfect water distribution piping as follows:
 1. Purge all new water distribution piping systems and parts of existing systems that have been altered, extended, or repaired prior to use.
 2. Use the purging and disinfecting procedure proscribed by the authority having jurisdiction or, in case a method is not proscribed by that authority, the procedure described in International Plumbing Code or as described below:
 - a. Flush the piping system with clean, potable water until dirty water does not appear at the points of outlet.
 - b. Fill the system or part thereof with a water/chlorine solution containing at least 50 parts per million of chlorine. Isolate (valve off) the system or part thereof and allow to stand for 24 hours.
 - c. Drain the system or part thereof of the previous solution and refill with a water/chlorine solution containing at least 200 parts per million of chlorine and isolate and allow to stand for 3 hours.
 - d. Following the allowed standing time, flush the system with clean, potable water until chlorine does not remain in the water coming from the system.
 - e. Submit water samples in sterile bottles to the authority having jurisdiction. Repeat the procedure if the biological examination made by the authority shows evidence of contamination.
- C. Prepare reports for all purging and disinfecting activities.

3.12 COMMISSIONING

- A. Fill the system. Check compression tanks to determine that they are not air bound and that the system is completely full of water.

- B. Before operating the system, perform these steps:
 - 1. Close drain valve, hydrants, and hose bibs.
 - 2. Open valves to full open position.
 - 3. Remove and clean strainers.
 - 4. Check pumps for proper direction of rotation. Correct improper wiring.
 - 5. Lubricate pump motors and bearings.

END OF SECTION - 15411

SECTION 15420
DRAINAGE AND VENT SYSTEMS

PART 1 - GENERAL

1.1 SUMMARY

- A. This Section includes building sanitary and storm drainage and vent piping systems, including drains and drainage specialties.

1.2 DEFINITIONS

- A. Building Drain: That part of the lowest piping of a drainage system which receives the discharge from soil, waste, and other drainage pipes inside the walls of the building and conveys it to the building sewer.
- B. Building Sewer: That part of the drainage system which extends from the end of the building drain and conveys its discharge to a public sewer, private sewer, individual sewage disposal system, or other point of disposal.
- C. Drainage System: Includes all the piping within a public or private premises which conveys sewage, rain water or other liquid wastes to a point of disposal. It does not include the mains of public sewer systems or a private or public sewage treatment or disposal plant.
- D. Vent System: A pipe or pipes installed to provide a flow of air to or from a drainage system, or to provide a circulation of air within such system to protect trap seals from siphonage and back pressure.

1.3 SUBMITTALS

- A. Product data for the following products:
 - 1. Drainage piping specialties

1.4 QUALITY ASSURANCE

- A. Regulatory Requirements: comply with the provisions of the following:
 - 1. International Plumbing Code.

1.5 SEQUENCING AND SCHEDULING

- A. Coordinate flashing materials installation of roofing, waterproofing, and adjoining substrate work.

- B. Coordinate the installation of drains in poured-in-place concrete slabs, to include proper drain elevations, installation of flashing, and slope of slab to drains.
- C. Coordinate with installation of sanitary and storm sewer systems as necessary to interface building drains with drainage piping systems.

PART 2 - PRODUCTS

2.1 ABOVE GROUND DRAINAGE AND VENT PIPE AND FITTINGS

- A. Copper Tube: ASTM B306, Type DWV for pipe, and cast-bronze, drainage pattern fittings, with soldered joints.
 - 1. Solder Filler Materials: ASTM B32, 50-50 tin-lead solder.
- B. Cast-Iron Soil Pipe: ASTM A74, Service weight, hub-and-spigot soil pipe and fittings.
 - 1. Clamps and compression gaskets: ASTM C564.
- C. Hubless Cast-Iron Soil Pipe: CISPI Standard 301, Service weight, cast-iron soil pipe and fittings, with neoprene gaskets conforming to CISPI Standard 310.

2.2 UNDERGROUND BUILDING DRAIN PIPE AND FITTINGS

- A. Cast-Iron Soil Pipe: ASTM A74, Extra-Heavy weight, hub-and-spigot soil pipe and fittings. Pipe and fittings shall have a heavy coating of coal tar varnish or asphaltum on both inside and outside surfaces.
 - 1. Neoprene Compression Gaskets: ASTM C564.

2.3 DRAINAGE PIPING SPECIALTIES

- A. Backwater Valves: Valve assembly shall be bronze fitted cast-iron, with bolted cover. Flapper shall provide a maximum 1/4 inch clearance between flapper and seat for air circulation. Valve ends shall suit piping material.
- B. Trap Primers: Bronze body valve with automatic vacuum breaker, with 1/2 inch connections matching piping system. Complying with ASSE 1018.

- C. Expansion Joints: Cast-iron body with adjustable bronze sleeve, bronze bolts with wing nuts.
- D. Cleanout Plugs: Cast-bronze or brass, threads complying with ANSI B2.1, countersunk head.
- E. Floor Cleanouts: Cast-iron body and frame, with cleanout plug and adjustable round top as follows:
 - 1. Nickel-Bronze Top: Manufacturer's standard cast unit with the following patterns:
 - a. Exposed rim type, with recess to receive 1/8 inch thick resilient floor finish.
 - b. Exposed rim type, with recess to receive 1 inch thick terrazzo floor finish.
 - c. Exposed finish type, standard mill finish.
 - d. Exposed flush type, standard non-slip scored or abrasive finish.
 - 2. Cast-iron Top: Manufacturer's standard cast unit with the following patterns:
 - a. Exposed flush type, standard mill finish.
 - b. Exposed flush type, standard non-slip scored or abrasive finish.
- F. Wall Cleanouts: Cast-iron body adaptable to pipe with cast-bronze or brass cleanout plug; stainless steel cover including screws.
- G. Flashing Flanges: Cast-iron watertight stack or wall sleeve with membrane flashing ring. Provide underdeck clamp and sleeve length as required.
- H. Vent Flashing Sleeves: Cast-iron calking type roof coupling for cast-iron stacks, cast-iron threaded type roof coupling for steel stacks, and cast-bronze stack flashing sleeve for copper tubing.
- I. Frost-Proof Vent Caps: Construct of galvanized iron, sized to provide 1 inch air space between outside of vent pipe and inside of flashing collar extension.
- J. Vandal-Proof Vent Caps: Cast-iron body full size of vent pipe, with calked base connection for cast-iron pipes, threaded base for steel pipes.

PART 3 - EXECUTION

3.1 EXAMINATION

- A. Verify existing grades, inverts, utilities, obstacles, and topographical conditions prior to installations.
- B. Examine rough-in requirements for plumbing fixtures and other equipment having drain connections to verify actual locations of piping connections prior to installation.
- C. Examine walls, floors, roof, and plumbing chases for suitable conditions where piping and specialties are to be installed.
- D. Do not proceed until unsatisfactory conditions have been corrected.

3.2 PIPE APPLICATIONS - ABOVE GROUND, WITHIN BUILDING

- A. Install copper tube with cast bronze fittings for 3 inch and smaller, drainage and vent pipe.
- B. Install hub-and-spigot, service weight, cast-iron soil pipe with lead and oakum calked joints for larger than 3 inch drainage and vent pipe.
- C. Install hub-and-spigot, service weight, cast-iron soil pipe with compression gasket joints for larger than 3 inch drainage and vent pipe.
- D. Install hubless, service weight, cast-iron soil pipe and fittings for larger than 3 inch drainage and vent pipe.

3.3 PIPE AND TUBE JOINT CONSTRUCTION

- A. Copper Tubing: Solder joints in accordance with the procedures specified in AWS "Soldering Manual."
- B. Cast-Iron Soil Pipe: Make lead and oakum calked joints, compression joints, and hubless joints in accordance with the recommendations in the CISPI Cast Iron Soil Pipe and Fittings Handbook, Chapter IV.

3.4 INSTALLATION

- A. General Locations and Arrangements: Drawings (plans, schematics, and diagrams) indicate the general location and arrangement of the piping systems. Location and arrangement of piping layout take into account many design considerations. So far as practical, install piping as required.
- B. Use fittings for all changes in direction and all branch connections.

- C. Install exposed piping at right angles or parallel to building walls. Diagonal runs are not permitted.
- D. Install piping free of sags or bends and with ample space between piping to permit proper insulation applications.
- E. Conceal all pipe installations in walls, pipe chases, utility spaces, above ceilings, below grade or floors.
- F. Install piping tight to slabs, beams, joists, columns, walls, and other permanent elements of the building. Allow sufficient space above removable ceiling panels to allow for panel removal.
- G. Exterior Wall Penetrations: Seal pipe penetrations through exterior walls using sleeves and mechanical sleeve seals. Pipe sleeves smaller than 6 inch shall be steel; pipe sleeves 6 inch and larger shall be sheet metal.
- H. Fire Barrier Penetrations: Where pipes pass through fire rated walls, partitions, ceilings and floors, maintain the fire rated integrity.
- I. Make changes in direction for drainage and vent piping using appropriate 45 degree wyes, half-wyes, or long sweep quarter, sixth, eighth, or sixteenth bends. Sanitary tees or short quarter bends may be used on vertical stacks of drainage lines where the change in direction of flow is from horizontal to vertical, except use long-turn tees where two fixtures are installed back to back and have a common drain. Straight tees, elbows, and crosses may be used on vent lines. No change in direction of flow greater than 90 degrees shall be made. Where different sizes of drainage pipes and fittings are connected, use proper size, standard increasers and reducers. Reduction of the size of drainage piping in the direction of flow is prohibited.
- J. Install underground building drains to conform with the plumbing code, and in accordance with the Cast Iron Soil Pipe Institute Engineering Manual. Lay underground building drains beginning at low point of systems, true to grades and alignment required with unbroken continuity of invert. Place bell ends of piping facing upstream. Install required gaskets in accordance with manufacturer's recommendations for use of lubricants, cements, and other special installation requirements. Maintain swab or drag in line and pull past each joint as it is completed.
- K. Install building drain pitched down at minimum slope of 1/4 inch per foot (2 percent) for piping 3 inch and smaller, and 1/8 inch per foot (1 percent) for piping 4 inch and larger.

- L. Install sleeve and mechanical sleeve seal through foundation wall for watertight installation.
- M. Install 1 inch thick extruded polystyrene over underground building drain piping not under building. Width of insulation shall extend minimum of 12" beyond each side of pipe. Install directly over, and center on pipe center line.
- N. Insulate all waste stacks for their entire length, and continue over fittings etc.

3.5 HANGERS AND SUPPORTS

- A. General: Hanger, supports, and anchors devices are specified in Division 15 Section "Basic Mechanical Materials and Methods."
- B. Install hangers for horizontal piping with the following maximum spacing and minimum rod sizes as required by current International Plumbing Codes and requirements of Governing Authorities:

3.6 INSTALLATION OF PIPING SPECIALTIES

- A. Install backwater valves in sanitary building drain piping as required, and as required by the plumbing code. For interior installation, provide cleanout cover flush to floor centered over backwater valve cover and of adequate size to remove valve cover for service.
- B. Install expansion joints on vertical risers as required, and as required by the plumbing code.
- C. Above Ground Cleanouts: Install in above ground piping and building drain piping as required, and:
 - 1. as required by plumbing code;
 - 2. at each change in direction of piping greater than 45 degrees;
 - 3. at minimum intervals of 50' for piping 4" and smaller and 100' for larger piping;
 - 4. at base of each vertical soil or waste stack.
- D. Cleanouts Covers: Install floor and wall cleanout covers for concealed piping, types as required.
- E. Flashing Flanges: Install flashing flange and clamping device with each stack and cleanout passing through waterproof membranes.

- F. Vent Flashing Sleeves: Install on stacks passing through roof, secure over stack flashing in accordance with manufacturer's instructions.
- G. Frost-Proof Vent Caps: Install frost-proof vent caps on each vent pipe passing through roof. Maintain 1 inch clearance between vent pipe and roof substrate.

3.7 CONNECTIONS

- A. Piping Runouts to Fixtures: Provide drainage and vent piping runouts to plumbing fixtures and drains, with approved trap, of sizes; but in no case smaller than required by the plumbing code.
- B. Locate piping runouts as close as possible to bottom of floor slab supporting fixtures or drains.

3.8 FIELD QUALITY CONTROL

- A. Inspections
 - 1. Do not enclose, cover, or put into operation drainage and vent piping system until it has been inspected and approved by the authority having jurisdiction.
 - 2. During the progress of the installation, notify the plumbing official having jurisdiction, at least 24 hours prior to the time such inspection must be made. Perform tests specified below in the presence of the plumbing official.
 - a. Rough-in Inspection: Arrange for inspection of the piping system before concealed or closed-in after system is roughed-in, and prior to setting fixtures.
 - b. Final Inspection: Arrange for a final inspection by the plumbing official to observe the tests specified below and to insure compliance with the requirements of the plumbing code.
 - 3. Reinspections: Whenever the piping system fails to pass the test or inspection, make the required corrections, and arrange for reinspected by the plumbing official.
 - 4. Reports: Prepare inspection reports, signed by the plumbing official.
- B. Piping System Test: Test drainage and vent system in accordance with the procedures of the authority having jurisdiction, or in the absence of a published procedure, as follows:

1. Test for leaks and defects all new drainage and vent piping systems and parts of existing systems, which have been altered, extended or repaired. If testing is performed in segments, submit a separate report for each test, complete with a diagram of the portion of the system tested.
2. Leave uncovered and unconcealed all new, altered, extended, or replaced drainage and vent piping until it has been tested and approved. Expose all such work for testing, that has been covered or concealed before it has been tested and approved.
3. Rough Plumbing Test Procedure: Except for outside leaders and perforated or open jointed drain tile, test the piping of plumbing drainage and venting systems upon completion of the rough piping installation. Tightly close all openings in the piping system, and fill with water to the point of overflow, but not less than 10 feet head of water. Water level shall not drop during the period from 15 minutes before the inspection starts, through completion of the inspection. Inspect all joints for leaks.
4. Finished Plumbing Test Procedure: After the plumbing fixtures have been set and their traps filled with water, their connections shall be tested and proved gas and water-tight. Plug the stack openings on the roof and building drain where it leaves the building, and introduce air into the system equal to a pressure of 1" water column. Use a "U" tube or manometer inserted in the trap of a water closet to measure this pressure. Air pressure shall remain constant without the introduction of additional air throughout the period of inspection. Inspect all plumbing fixture connections for gas and water leaks.
5. Repair all leaks and defects using new materials and retest system or portion thereof until satisfactory results are obtained.
6. Prepare reports for all tests and required corrective action.

3.9 ADJUSTING AND CLEANING

- A. Clean interior of piping system. Remove dirt and debris as work progresses.
- B. Clean drain strainers, domes, and traps. Remove dirt and debris.

3.10 PROTECTION

- A. Protect drains during remainder of construction period, to avoid clogging with dirt and debris, and to prevent damage from traffic and construction work.
- B. Place plugs in ends of uncompleted piping at end of day or whenever work stops

END OF SECTION 15420

SECTION 15440
PLUMBING FIXTURES

PART 1 - GENERAL

1.1 SUMMARY

- A. This Section includes plumbing fixtures and trim, fittings, and accessories, appurtenances, and supports associated with plumbing fixtures.
- B. Related Sections: The following Sections contain requirements that relate to this Section:
 - 1. Division 15 Section "Drainage and Vent Systems".
 - 2. Division 15 Section "Valves" for valves used as supply stops.
 - 3. Division 15 Section "Water Distribution Piping".

1.2 SUBMITTALS

- A. General: Submit the following in accordance with Conditions of Contract and Division 1 Specification Sections.
- B. Product data for each type of plumbing fixture as scheduled on drawings, including fixture and trim, fittings, faucets, accessories, supports, construction details, dimensions of components, flow rates of fixtures, and finishes.

1.3 QUALITY ASSURANCE

- A. Design Concept: The drawings indicate types of plumbing fixtures and are based on the specific descriptions, manufacturers, models, and numbers indicated. Plumbing fixtures having equal performance characteristics by other manufacturers may be considered provided that deviations in dimensions, operation, color or finish, or other characteristics are minor and do not change the design concept or intended performance as judged by the Engineer. Burden of proof for equality of plumbing fixtures is on the proposer.
- B. Codes and Standards: As specified in Section 15010.

1.4 DELIVERY, STORAGE, AND HANDLING

- A. Deliver plumbing fixtures in manufacturer's protective packing, crating, and covering.
- B. Store plumbing fixtures on elevated platforms in a dry location.

1.5 EXTRA MATERIALS

- A. Deliver extra materials to Owner. Furnish extra materials described below matching products installed, packaged with protective covering for storage, and identified with labels clearly describing contents.
 - 1. Faucet Washers and O-rings: Furnish quantity of identical units not less than 10 percent of amount of each installed.
 - 2. Faucet Cartridges and O-rings: Furnish quantity of identical units not less than 5 percent of amount of each installed.
 - 3. Water Closet Tank Repair Kits: Furnish quantity of identical flush valve units not less than 5 percent of amount of each type installed.
 - 4. Toilet Seats: Furnish quantity of identical units not less than 5 percent of amount of each type toilet seat installed.

PART 2 - PRODUCTS

2.1 PLUMBING FIXTURES, GENERAL

- A. Fixtures shall be in accordance with specifications and scheduled on the drawings.
- B. Flow rates shall comply with EPA WaterSense where applicable.
- C. Provide air chambers at all fixtures.

2.2 FAUCETS

- A. Faucets General: Unless otherwise specified, provide faucets that are cast brass with polished chrome-plated finish.

2.3 FITTINGS, EXCEPT FAUCETS

- A. Fittings General: Unless otherwise specified, provide fittings fabricated of brass, with a polished chrome plated finish.
- B. Sink Supplies and Stops: Handle angle stop, having 1/2-inch NPS inlet with wall flange and 1/2-inch by 12-inch flexible tubing riser outlet.
- C. Sink Traps: Cast brass, 1-1/2 inch NPS adjustable P-trap with cleanout, 17 gage tubular waste to wall, and wall flange.
- D. Sink Continuous Wastes: Polished chrome-plated, tubular brass, 1-1/2 inches, 17 gauge, with brass nuts on slip inlets, and of configurations indicated.

- G. Escutcheons: Polished chrome-plated, sheet steel wall flange with friction clips.
- H. Deep Pattern Escutcheons: Wall flange with set screw or sheet steel wall flange with friction clips, of depth adequate to conceal protruding roughing-in fittings.
- I. Provide fittings specified as part of a fixture description, in lieu of fitting requirements above.

2.4 PLUMBING FIXTURE SUPPORTS

- A. Supports: ASME A112.6.1M, categories and types as required for wall-hanging fixtures specified, and wall reinforcement.
- B. Support categories are:
 - 1. Chair Carriers, Heavy Duty: Supports with rectangular steel uprights for wall-hanging fixtures.
 - 2. Reinforcement: 2-inch by 4-inch wood blocking between studs or 1/4-inch by 6-inch steel plates attached to studs, in wall construction, to secure floor-mounted and special fixtures to wall.
- C. Support Types: Provide support of category specified, of type having features required to match fixture.

PART 3 - EXECUTION

3.1 EXAMINATION

- A. Examine roughing-in for potable cold water and hot water supplies and soil, waste, and vent piping systems to verify actual locations of piping connections prior to installing fixtures.
- B. Examine walls, floors, and cabinets for suitable conditions where fixtures are to be installed.
- C. Do not proceed until unsatisfactory conditions have been corrected.

3.2 APPLICATION

- A. Install plumbing fixtures and specified components, in accordance with designations and locations indicated on Drawings.

- B. Install supports for plumbing fixtures in accordance with categories indicated, and of type required:

3.3 INSTALLATION OF PLUMBING FIXTURES

- A. Install plumbing fixtures level and plumb, in accordance with fixture manufacturers' written installation instructions, roughing-in drawings, and referenced standards.
- B. Install water closets with closet flanges and gasket seals.
- C. Fasten wall hanging plumbing fixtures securely to supports attached to building substrate.
- D. Secure supplies behind wall or within wall pipe space, providing rigid installation.
- E. Install stop valve in an accessible location in each water supply to each fixture.
- F. Install trap on fixture outlet except for fixtures having integral trap.
- G. Install escutcheons at each wall, floor, and ceiling penetration in exposed finished locations and within cabinets and millwork. Use deep pattern escutcheons where required to conceal protruding pipe fittings.
- H. Seal fixtures to walls, floors, and counters using a sanitary-type, one-part, mildew-resistant, silicone sealant.

3.4 CONNECTIONS

- A. Piping installation requirements are specified in other sections of Division 15. The Drawings indicate general arrangement of piping, fittings, and specialties. The following are specific connection requirements:
 - 1. Install piping connections between plumbing fixtures and piping systems and plumbing equipment specified in other sections of Division 15.

3.5 FIELD QUALITY CONTROL

- A. Inspect each installed fixture for damage. Replace damaged fixtures and components.

- B. Test fixtures to demonstrate proper operation upon completion of installation and after units are water pressurized. Replace malfunctioning fixtures and components, then retest. Repeat procedure until all units operate properly.

3.6 ADJUSTING AND CLEANING

- A. Operate and adjust faucets and controls. Replace damaged and malfunctioning fixtures, fittings, and controls.
- B. Adjust water pressure at drinking fountains, electric water coolers, and faucets, and flushometers having controls, to provide proper flow and stream.
- C. Replace washers of leaking and dripping faucets and stops.
- D. Clean fixtures, fittings, and spout and drain strainers with manufacturers' recommended cleaning methods and materials.
- E. Review the data in Operating and Maintenance Manuals.

3.7 PROTECTION

- A. Provide protective covering for installed fixtures and fittings.
- B. Do not allow use of fixtures for temporary facilities, except when approved in writing by the Owner.

3.8 FIXTURE SCHEDULE

- A. Provide plumbing fixtures as scheduled on the drawings.

END OF SECTION 15440

SECTION 15870
POWER VENTILATORS

PART 1 - GENERAL

1.1 SUMMARY

A. This Section includes the following types of power ventilators:

1. Ceiling-mounted ventilators.

1.2 SUBMITTALS

A. General: Submit the following in accordance with Conditions of Contract and Division 1 Specification Sections:

1. Product data for selected models, including specialties, accessories, and the following:
 - a. Certified fan performance curves with system operating conditions indicated.
 - b. Certified fan sound power ratings.
 - c. Motor ratings and electrical characteristics plus motor and fan accessories.
 - d. Materials gages and finishes, including color charts.
 - e. Dampers, including housings, linkages, and operators.
2. Shop drawings from manufacturer detailing equipment assemblies and indicating dimensions, weights, required clearances, components, and location and size of field connections.
3. Coordination drawings, in accordance with Division 15 Section "Basic Mechanical Requirements," for roof penetration requirements and for reflected ceiling plans drawn accurately to scale and coordinating penetrations and units mounted above ceiling. Show the following:
 - a. Roof framing and support members relative to duct penetrations.
 - b. Ceiling suspension members.
 - c. Method of attaching hangers to building structure.
 - d. Size and location of initial access modules for acoustical tile.
 - e. Ceiling-mounted items including light fixtures, diffusers, grilles, speakers, sprinkler heads, access panels, and special moldings.
4. Wiring diagrams that detail power, signal, and control wiring. Differentiate between manufacturer-installed wiring and field-installed wiring.

5. Product certificates, signed by manufacturers of air-handling units, certifying that their products comply with specified requirements.
6. Maintenance data for air-handling units, for inclusion in Operating and Maintenance Manual specified in Division 1 and Division 15 Section "Basic Mechanical Requirements."

1.3 QUALITY ASSURANCE

- A. UL Compliance: Fans shall be designed, manufactured, and tested in accordance with UL 705 "Power Ventilators."
- B. UL Compliance: Fans and components shall be UL listed and labeled.
- C. Nationally Recognized Testing Laboratory and NEMA Compliance (NRTL): Fans and components shall be NRTL listed and labeled. The term "NRTL" shall be as defined in OSHA Regulation 1910.7.
- D. NEMA Compliance: Motors and electrical accessories shall comply with NEMA standards.
- E. Electrical Component Standard: Components and installation shall comply with NFPA 70 "National Electrical Code."

1.4 DELIVERY, STORAGE, AND HANDLING

- A. Lift and support units with the manufacturer's designated lifting or supporting points.
- B. Disassemble and reassemble units as required for movement into the final location following manufacturer's written instructions.
- C. Deliver fan units as a factory-assembled unit to the extent allowable by shipping limitations, with protective crating and covering.

1.5 SEQUENCING AND SCHEDULING

- A. Coordinate the installation of equipment supports, and roof penetrations specified in Division 7.
- B. Coordinate the size and location of structural steel support members.

1.6 EXTRA MATERIALS

- A. Furnish one additional complete set of belts for each belt-driven fan.

PART 2 - PRODUCTS

2.1 MANUFACTURERS

- A. Available Manufacturers: Subject to compliance with requirements, manufacturers offering products that may be incorporated in the Work include but are not limited to, the following:
1. Centrifugal Roof Ventilators:
 - a. Carnes Company, Inc.
 - b. Cook (Loren) Co.
 - c. Greenheck Fan Corp.
 2. Ceiling-Mounted Ventilators:
 - a. Carnes Company, Inc.
 - b. Cook (Loren) Co.
 - c. Greenheck Fan Corp.

2.2 SOURCE QUALITY CONTROL

- A. Testing Requirements: The following factory tests are required:
- 1 Sound Power Level Ratings: Comply with AMCA Standard 301 "Method for Calculating Fan Sound Ratings From Laboratory Test Data." Test fans in accordance with AMCA Standard 300 "Test Code for Sound Rating." Fans shall be licensed to bear the AMCA Certified Sound Ratings Seal.
 - 2 Fan Performance Ratings: Establish flow rate, pressure, power, air density, speed of rotation, and efficiency by factory tests and ratings in accordance with AMCA Standard 210/ASHRAE Standard 51 - Laboratory Methods of Testing Fans for Rating.

2.3 FANS, GENERAL

- A. General: Provide fans that are factory fabricated and assembled, factory tested, and factory finished with indicated capacities and characteristics.
- B. Fans and Shafts: Statically and dynamically balanced and designed for continuous operation at the maximum rated fan speed and motor horsepower.

1. Fan Shaft: Turned, ground, and polished steel designed to operate at no more than 70 percent of the first critical speed at the top of the speed range of the fan's class.
- C. Belt Drives: Factory mounted, with final alignment and belt adjustment made after installation.
1. Service Factor: 1.4.
- D. Belts: Oil-resistant, nonsparking, and nonstatic.
- E. Motors and Fan Wheel Pulleys: Adjustable pitch for use with motors through 15 HP; fixed pitch for use with motors larger than 15 HP. Select pulley so that pitch adjustment is at the middle of the adjustment range at fan design conditions.
1. Belt Guards: Provide steel belt guards for motors mounted on the outside of the fan cabinet.
- F. Shaft Bearings: Provide type indicated, having a median life "Rating Life" (AFBMA (L(50)) of 200,000, calculated in accordance with AFBMA Standard 9 for ball bearings and AFBMA Standard 11 for roller bearings.
- G. Factory Finish: The following finishes are required:
1. Sheet Metal Parts: Prime coating prior to final assembly.
 2. Exterior Surfaces: Baked-enamel finish coat after assembly.

2.4 CEILING-MOUNTED VENTILATORS

- A. General Description: Centrifugal fan designed for installation in ceiling, wall, or concealed inline applications.
- B. Housing: Galvanized steel lined with acoustical insulation.
- C. Fan Wheel: Centrifugal wheels directly mounted on motor shaft Fan shrouds, motor, and fan wheel shall be removable for service.
- D. Grille: Stainless steel, louvered grille with flange on intake and thumbscrew attachment to fan housing.
- E. Electrical Requirements: Junction box for electrical connection on housing and receptacle for motor plug-in.

- F. Remote Fan Speed Control: Solid state, capable of controlling fan speed from full speed to approximately half speed.
- G. Accessories: Manufacturer's standard roof jack, wall cap, and transition fittings as required.

2.6 MOTORS

- A. Torque Characteristics: Sufficient to accelerate the driven loads satisfactorily.
- B. Motor Sizes: Minimum sizes and electrical characteristics as indicated. If not indicated, large enough so that the driven load will not require the motor to operate in the service factor range.
- C. Temperature Rating: 50 deg C maximum temperature rise at 40 deg C ambient for continuous duty at full load (Class A Insulation).
- D. Service Factor: 1.15 for polyphase motors and 1.35 for single-phase motors.
- E. Motor Construction: NEMA Standard MG 1, general purpose, continuous duty, Design B. Provide permanent-split capacitor classification motors for shaft-mounted fans and capacitor start classification for belted fans.
 - 1. Bases: Adjustable.
 - 2. Bearings: The following features are required:
 - a. Ball or roller bearings with inner and outer shaft seals.
 - b. Grease lubricated.
 - c. Designed to resist thrust loading where belt drives or other drives produce lateral or axial thrust in motor.
 - 3. Enclosure Type: The following features are required:
 - a. Open drip-proof motors where satisfactorily housed or remotely located during operation.
 - b. Guarded drip-proof motors where exposed to contact by employees or building occupants.
 - 4. Overload protection: Built-in, automatic reset, thermal overload protection.
 - 5. Noise rating: Quiet.
 - 6. Efficiency: Energy-efficient motors shall have a minimum efficiency as scheduled in accordance with IEEE Standard 112, Test Method B. If efficiency not specified, motors shall have a higher efficiency than

"average standard industry motors" in accordance with IEEE Standard 112, Test Method B.

7. Nameplate: Indicate the full identification of manufacturer, ratings, characteristics, construction, and special features.
- F. Starters, Electrical Devices, and Wiring: Electrical devices and connections are specified in Division 16.

PART 3 - EXECUTION

3.1 EXAMINATION

- A. Examine areas and conditions, with Installer present, for compliance with requirements for installation tolerances, roof curbs, equipment supports, and other conditions affecting performance of fans.
- B. Do not proceed until unsatisfactory conditions have been corrected.

3.2 INSTALLATION, GENERAL

- A. Install fans level and plumb, in accordance with manufacturer's written instructions. Support units as described below, using the vibration control devices indicated. Vibration control devices are specified in Division 15 Section "Vibration Controls."
 1. Suspended Units: Suspend units from structural steel support frame using threaded steel rods and vibration isolation springs.
- B. Arrange installation of units to provide access space around air- handling units for service and maintenance.

3.3 CONNECTIONS

- A. Duct installations and connections are specified in other Division 15 sections. Make final duct connections with flexible connections.
- B. Electrical Connections: The following requirements apply:
 1. Electrical power wiring is specified in Division 16.
 2. Temperature control wiring and interlock wiring are specified in Division 15 Section "Electrical Control Systems."

3. Temperature control wiring and interlock wiring are specified in Division 15 Section "Pneumatic Control Systems."
4. Grounding: Connect unit components to ground in accordance with the National Electrical Code.

3.4 FIELD QUALITY CONTROL

- A. Manufacturer's Field Inspection: Arrange and pay for a factory- authorized service representative to perform the following:
 1. Inspect the field assembly of components and installation of fans including ductwork and electrical connections.
 2. Prepare a written report on findings and recommended corrective actions.

3.5 ADJUSTING, CLEANING, AND PROTECTING

- A. Adjust damper linkages for proper damper operation.
- B. Clean unit cabinet interiors to remove foreign material and construction dirt and dust. Vacuum clean fan wheel and cabinet.

3.6 COMMISSIONING

- A. Final Checks Before Start-Up: Perform the following operations and checks before start-up:
 1. Remove shipping blocking and bracing.
 2. Verify unit is secure on mountings and supporting devices and that connections for piping, ductwork, and electrical are complete. Verify proper thermal overload protection is installed in motors, starters, and disconnects.
 3. Perform cleaning and adjusting specified in this Section.
 4. Disconnect fan drive from motor, verify proper motor rotation direction, and verify fan wheel free rotation and smooth bearings operations. Reconnect fan drive system, align belts, and install belt guards.
 5. Lubricate bearings, pulleys, belts, and other moving parts with factory-recommended lubricants.

6. Disable automatic temperature control operators.
- B. Starting procedures for fans:
 1. Energize motor; verify proper operation of motor, drive system, and fan wheel. Adjust fan to indicated RPM.
 2. Measure and record motor electrical values for voltage and amperage.
 - a. Replace fan and motor pulleys as required to achieve design conditions.
 - C. Shut unit down and reconnect automatic temperature control operators.

3.7 DEMONSTRATION

- A. Demonstration Services: Arrange and pay for a factory-authorized service representative to train Owner's maintenance personnel on the following:
 1. Procedures and schedules related to start-up and shutdown, troubleshooting, servicing, preventative maintenance, and how to obtain replacement parts.
 2. Familiarization with contents of Operating and Maintenance Manuals specified in Division 1 Section "Project Closeout" and Division 15 Section "Basic Mechanical Requirements."
- B. Schedule training with at least 7 days' advance notice.

END OF SECTION 15870

SECTION 16010 – BASIC ELECTRICAL REQUIREMENTS

PART 1 - GENERAL

1.1 RELATED DOCUMENTS

- A. Drawings and general provisions of Contract, including General and Supplementary Conditions and Division 1 Specification Sections, apply to this and the other sections of Division 16.

1.2 SUMMARY

- A. This Section includes general administrative, procedural, and other requirements for electrical installations. The following requirements are included in this Section to expand the requirements specified in Divisions 1 through 16:
 - 1. Submittals.
 - 2. Quality control.
 - 3. Definitions and abbreviations.
 - 4. Scheduling.
 - 5. Coordination drawings.
 - 6. Record documents.
 - 7. Maintenance manuals.
 - 8. Delivery, storage, and handling.
 - 9. Products.
 - 10. Rough-ins.
 - 11. Electrical installations.
 - 12. Permits and instructions.
 - 13. Field quality control.
 - 14. Protection.
 - 15. Additional work.
 - 16. Electrical schedules.
 - 17. Cutting and patching.

1.3 SUBMITTALS

- A. General: Follow the procedures specified in Division 1.
- B. Increase, by the quantity listed below, the number of electrical related shop drawings, product data, and samples submitted, to allow for required distribution plus two copies of each submittal required, which will be retained by the Electrical Consulting Engineer.
 - 1. Shop Drawings - Initial Submittal: 1 additional blue- or black-line prints.
 - 2. Shop Drawings - Final Submittal: 1 additional blue- or black-line prints.
 - 3. Product Data: 1 additional copy of each item.
 - 4. Samples: 1 addition as set.
- C. Additional copies may be required by individual sections of these Specifications.

1.4 QUALITY CONTROL

- A. Functional and Operational Test Procedure:

1. Test procedure to completely test all systems as to their functional and sequential operation.
 2. Submit two (2) draft copies for review before conducting test.
 3. Certify that the test procedure was used and testing completed, and that all systems are operational and functioning properly.
 4. Submit certified Test Procedure for review prior to the date of final inspection.
 5. Systems to be covered by test procedure:
 - a. Power Distribution
 - b. Lighting Systems
 - c. Emergency Lighting System
- B. Other Tests and Certifications for:
1. Grounding System: As specified under Section 16452.

1.5 DEFINITIONS AND ABBREVIATIONS

- A. Electrical Definitions: As defined by NEC, Article 100.
- B. The term "indicated" shall mean "as shown on contract documents (specifications, drawings, and related attachments)".
- C. The term "provide" shall mean "to furnish, install and connect completely".
- D. The term "size" shall mean one or more of the following: "length, current and voltage rating, number of poles, NEMA size, and other similar electrical characteristics".
- E. The term "space" on panelboard and switchboard schedules shall mean "provide space to install the number of poles and size of the protective device indicated with all the necessary buss and fittings to install the device at some future date".

1.6 SCHEDULING

- A. Coordinate electrical work with other divisions of this project.
- B. Coordinate electrical work with Owner.
- C. Written requests for approval for planned shutdowns or interruption of Owner's operation or equipment shall be made 72 hours prior to the start of the requested periods.
- D. Written notification for on site training of Owner's personnel shall be made 1 week prior to the start of the requested training period.

1.7 COORDINATION DRAWINGS

- A. Prepare coordination drawings in accordance with Division 1 to a scale of 1/4"=1'-0" or larger; detailing major elements, components, and systems of electrical equipment and materials in relationship with other systems,

installations, and building components. Indicate locations where space is limited for installation and access and where sequencing and coordination of installations are of importance to the efficient flow of the Work, including (but not necessarily limited to) the following:

1. Indicate the proposed locations of major raceway systems, equipment, and materials. Include the following:
 - a. Clearances for servicing equipment, including space for equipment disassembly required for periodic maintenance.
 - b. Fire-rated wall and floor penetrations.
 - c. Equipment connections and support details.
2. Indicate scheduling, sequencing, movement, and positioning of large equipment into the building during construction.
3. Prepare floor plans, elevations, and details to indicate penetrations in floors, walls, and ceilings and their relationship to other penetrations and installations.
4. Prepare reflected ceiling plans to coordinate and integrate installations, air outlets and inlets, light fixtures, raceway systems components, Exhaust/Kitchen hoods, and other ceiling-mounted devices.

1.8 RECORD DOCUMENTS

- A. Prepare record documents in accordance with the requirements in Division 1. In addition to the requirements specified in Division 1, indicate installed conditions for:
 1. Major raceway systems, size and location, for both exterior and interior; locations of control devices; distribution and branch electrical circuitry; and fuse and circuit breaker size and arrangements.
 2. Equipment locations (exposed and concealed), dimensioned from prominent building lines.
 3. Approved substitutions, Contract Modifications, and actual equipment and materials installed.

1.9 MAINTENANCE MANUALS

- A. Prepare maintenance manuals in accordance with Division 1. In addition to the requirements specified in Division 1, include the following information for equipment items:
 1. Description of function, normal operating characteristics and limitations, performance curves, engineering data and tests, and complete nomenclature and commercial numbers of replacement parts.
 2. Manufacturer's printed operating procedures to include start-up, break-in, and routine and normal operating instructions; regulation, control, stopping, shutdown, and emergency instructions; and summer and winter operating instructions.
 3. Maintenance procedures for routine preventative maintenance and troubleshooting; disassembly, repair, and reassembly; aligning and adjusting instructions.
 4. Servicing instructions and lubrication charts and schedules.

1.10 DELIVERY, STORAGE, AND HANDLING

- A. Deliver products to the project properly identified with names, model numbers, types, grades, compliance labels, and other information needed for identification.

PART 2 - PRODUCTS

2.1 ACCEPTABLE MANUFACTURERS

- A. As specified under other RELATED SECTIONS.

- B. As specified on Drawings.

2.2 MATERIAL

- A. General:

1. Unless otherwise indicated, all raceways for service, feeders, branch and control wiring are RSC or IMC. See Section 16110.
2. Unless otherwise indicated, wiring to equipment and motors shall be installed in liquid tight flexible conduit, or in interior dry locations in flexible metal conduit, with a maximum length of six (6) feet.
3. Unless otherwise indicated, all conductors to be copper THHN/THWN-2.
4. Unless otherwise indicated, all outlet and switch boxes to be cast iron with threaded hubs.
5. In interior protected locations, where recessed in ceiling and walls, outlet and switch boxes may be stamped steel.
6. Unless otherwise indicated, provide heavy duty grade, 20 ampere, receptacles and switches. Plates shall be 302 stainless steel, satin finish. Plates for surface mounted interior boxes may be stamped steel. Plates exposed to weather or water to be metal, weatherproof type. Receptacles, switches and associated cover plates color by Architect/Owner.

- B. As specified under RELATED SECTIONS.

- C. As specified on Drawings.

2.3 EQUIPMENT

- A. General:

1. Unless otherwise indicated, externally operated safety switches are unfused, solid neutral, heavy duty, and selected to meet the load requirements.

- B. As specified under RELATED SECTIONS.

- C. As specified on Drawings.

2.4 FABRICATION

- A. General:

1. Unless otherwise indicated, all enclosures are NEMA Type 1. NEMA Type 3R shall be used for wet/damp locations.
- B. As specified under RELATED SECTIONS.
- C. As specified on Drawings.

PART 3 - EXECUTION

3.1 ROUGH-IN

- A. Verify final locations for rough-ins with field measurements and with the requirements of the actual equipment to be connected.
- B. Refer to equipment specifications in Divisions 2 through 16 for rough-in requirements.
- C. Contractor is to provide connections, both power and control as noted, for Mechanical equipment. Division 16 shall coordinate the respective installations with other project disciplines.

3.2 ELECTRICAL INSTALLATIONS

- A. General: Sequence, coordinate, and integrate the various elements of electrical systems, materials, and equipment. Comply with the following requirements:
 1. Coordinate electrical systems, equipment, and materials installation with other building components. Electrical plans and details do not show all interferences and conditions, visible and/or hidden, that may exist. Before selecting material and equipment, and proceeding with work, inspect areas where material and equipment are to be installed to insure suitability, and check needed space for placements, clearances and interconnections. Before cutting or drilling into building elements inspect and layout work to avoid damaging structural elements or building utilities.
 2. Electrical plans, details, and diagrams show the general location and arrangement of electrical systems. They are diagrammatic and do not show all conduit bodies, connectors, bends, fittings, hangers, and additional pull and junction boxes which the Contractor must provide to complete the electrical system.
 3. Verify all dimensions by field measurements.
 4. Arrange for chases, slots, and openings in other building components during progress of construction, to allow for electrical installations.
 5. Coordinate the installation of required supporting devices and sleeves to be set in poured-in-place concrete and other structural components, as they are constructed.
 6. Sequence, coordinate, and integrate installations of electrical materials and equipment for efficient flow of the Work. Give particular attention to large equipment requiring positioning prior to closing in the building. Verify dimensional constraints of building door openings and passageways, and

- the maximum floor loadings, for the movement of selected material and equipment. Order equipment and material, broken down as may be required, to meet these constraints.
7. Measurement from above finished floor (AFF) shall be taken from the finished floor surface to the top of wall receptacles and switch boxes, to the centerline of wall lighting outlet boxes, to the top of wall mounted equipment enclosures, to the centerline of top most switch handle, or to the lowest surface of ceiling lighting fixtures and other ceiling mounted equipment.
 - a. Unless otherwise indicated, wall switch boxes shall be 44 inches AFF. Refer to Architectural Drawings.
 - b. Unless otherwise indicated, receptacle boxes shall be 18 inches AFF. Receptacle mounted above counter and at furniture locations shall be coordinated with architectural elements. Refer to Architectural Drawings. Coordinate with Architect.
 8. Where mounting heights are not detailed or dimensioned, install systems, materials, and equipment to provide the maximum headroom possible. Switch and receptacle heights shall meet handicap accessible code requirements.
 9. Coordinate connection of electrical systems with incoming utilities and services. Comply with requirements of governing regulations, power, telephone, and data service companies, and controlling agencies. Provide required connection for each service. Provide power connection to equipment. Coordinate with other Divisions.
 10. Install systems, materials, and equipment to conform with approved submittal data, including coordination drawings, to greatest extent possible. Conform to arrangements indicated by the Contract Documents, recognizing that portions of the Work are shown only in diagrammatic form. Where coordination requirements conflict with individual system requirements, refer conflict to the Engineer.
 11. Install systems, materials, and equipment level and plumb, parallel and perpendicular to other building systems and components, where installed exposed in finished spaces.
 12. Conduit Sizing:
 - a. Unless otherwise indicated, conduit size for indicated conductor shall be based on Chapter 9 of NEC.
 - b. Conduit: 1/2 inch minimum size.
 13. Install electrical equipment to facilitate servicing, maintenance, and repair or replacement of equipment components. As much as practical, connect equipment for ease of disconnecting, with minimum of interference with other installations. Measure and locate placement of equipment and materials in relation to building structure and surfaces, and between equipment to be installed and wired. Maintain required minimum access spacing for equipment and enclosures.
 14. Install access panel or doors where units are concealed behind finished surfaces. Access panels and doors are specified elsewhere.

15. Install systems, materials, and equipment giving right-of-way priority to systems required to be installed at a specified slope.
16. Unless otherwise noted, individual raceway runs are required for each kitchen equipment component. Connection shall be routed down existing walls exposed, concealed in new walls, and/or under slab to the respective area as noted.

3.3 PERMITS AND INSPECTIONS

- A. Obtain and pay for all required permits and arrange for all required inspections in accordance with state and local governing authorities.
- B. Final Electrical Inspection Certificate from inspection agency or governing authority.

3.4 FIELD QUALITY CONTROL

- A. Perform field tests as specified under other electrical sections.
- B. Arrange for local Inspection Authorities to inspect work performed prior to burial, closing-in behind wall and above ceiling, or encased in concrete. Also arrange for final inspection of work and obtain Final Inspection Certificate before final inspection of work by Owner or his representative.

3.5 PROTECTION

- A. Protect personnel from coming in contact with live parts.
- B. During remodeling or alteration work, maintain fire ratings of walls, floors and ceilings when work is left unattended.
- C. Protect from damage and theft equipment and materials provided or supplied by others in accordance with manufacturer's recommendation and warranties, and with electrical standards and practices.

3.6 ADDITIONAL WORK

- A. Provide lighting systems including emergency lighting.
- B. Provide power and control wiring for Mechanical equipment.

3.7 ELECTRICAL SCHEDULES

- A. As specified in related sections or shown on drawings.

3.8 CUTTING AND PATCHING

- A. General: Perform cutting and patching in accordance with Division 1. In addition to the requirements specified in Division 1, the following requirements apply:
 1. Perform cutting, fitting, and patching of electrical equipment and materials required to:
 - a. Uncover Work to provide for installation of ill-timed Work.
 - b. Remove and replace defective Work.

- c. Remove and replace Work not conforming to requirements of the Contract Documents.
 - d. Remove samples of installed Work as specified for testing.
 - e. Install equipment and materials in existing structures.
 - f. Upon written instructions from the Engineer, uncover and restore Work to provide for Engineer observation of concealed Work.
2. Cut, remove, and legally dispose of selected electrical equipment, components, and materials as indicated, including but not limited to removal of electrical items indicated to be removed and items made obsolete by the new Work.
 3. Protect the structure, furnishings, finishes, and adjacent materials not indicated or scheduled to be removed.
 4. Provide and maintain temporary partitions or dust barriers adequate to prevent the spread of dust and dirt to adjacent areas.
 5. Protection of Installed Work: During cutting and patching operations, protect adjacent installations.
 6. Patch existing finished surfaces and building components using new materials matching existing materials and experienced Installers. Installers' qualifications refer to the materials and methods required for the surface and building components being patched.
 7. Patch finished surfaces and building components using new materials specified for the original installation and experienced Installers. Installers' qualifications refer to the materials and methods required for the surface and building components being patched.

END OF SECTION 16010

SECTION 16050 – BASIC ELECTRICAL MATERIALS AND METHODS

PART 1 - GENERAL

1.1 RELATED DOCUMENTS

- A. Drawings and general provisions of Contract, including General and Supplementary Conditions and Division 1 Specification Sections, apply to this Section.
- B. Requirements specified in other Division 16 Sections apply to this section.

1.2 SUMMARY

- A. This Section includes limited scope general construction materials and methods for application with electrical installations as follows:
 - 1. Miscellaneous metals for support of electrical materials and equipment.
 - 2. Fire rated wood grounds, nailers, blocking, fasteners, and anchorage for support of electrical materials and equipment.
 - 3. Joint sealers for sealing around electrical materials and equipment; and for sealing penetrations in fire and smoke barriers, floors, and foundation walls.
 - 4. Access panels and doors in walls, ceilings, and floors for access to electrical materials and equipment.

1.3 SUBMITTALS

- A. General: Submit the following in accordance with Conditions of Contract and Division 1 Specification Sections.
- B. Product data for the following products:
 - 1. Access panels and doors.
 - 2. Joint sealers.
- C. Shop drawings detailing fabrication and installation for metal fabrications, and wood supports and anchorage for electrical materials and equipment.
- D. Coordination drawings for access panel and door locations in accordance with Division 16 Section "Basic Electrical Requirements."
- E. Samples of joint sealer, consisting of strips of actual products showing full range of colors available for each product.
- F. Welder certificates, signed by Contractor, certifying that welders comply with requirements specified under "Quality Assurance" article of this Section.

- G. Schedules indicating proposed methods and sequence of operations for selective demolition prior to commencement of Work. Include coordination for shut off of electrical service, and details for dust and noise control.
 - 1. Coordinate sequencing with construction phasing and Owner occupancy as specified in other Divisions.

1.4 QUALITY ASSURANCE

- A. Installer Qualifications: Engage an experienced Installer for the installation and application of joint sealers, access panels, and doors.
- B. Qualify welding processes and welding operators in accordance with AWS D1.1 "Structural Welding Code Steel."
 - 1. Certify that each welder has satisfactorily passed AWS qualification tests for welding processes involved and, if pertinent, has undergone recertification.
- C. Fire Resistance Ratings: Where a fire resistance classification is indicated, provide access door assembly with panel door, frame, hinge, and latch from manufacturer listed in the UL "Building Materials Directory" for rating shown.
 - 1. Provide UL Label on each fire rated access door.

1.5 DELIVERY, STORAGE, AND HANDLING

- A. Deliver joint sealer materials in original unopened containers or bundles with labels informing about manufacturer, product name and designation, color, expiration period for use, pot life, curing time, and mixing instructions for multi component materials.
- B. Store and handle joint sealer materials in compliance with the manufacturers' recommendations to prevent their deterioration and damage.

1.6 PROJECT CONDITIONS

- A. Conditions Affecting Selective Demolition: The following project conditions apply:
 - 1. Protect adjacent materials indicated to remain or in the other phases of the proposed construction. Install and maintain dust and noise barriers to keep dirt, dust, and noise from being transmitted to adjacent areas. Remove protection and barriers after demolition operations are complete.
 - 2. Locate, identify, and protect electrical services passing through demolition area and serving other areas outside the demolition limits. Maintain services to areas outside demolition limits. When services must be interrupted, install temporary services for affected areas.
 - 3. Arrange for electric service change-overs during periods when the building is not occupied. This may include week-ends and evening hours. Coordinate with Owner's representatives.

- B. Environmental Conditions: Apply joint sealers under temperature and humidity conditions within the limits permitted by the joint sealer manufacturer. Do not apply joint sealers to wet substrates.

1.7 SEQUENCE AND SCHEDULING

- A. Coordinate the shut off and disconnection of electrical power with the Owner.
- B. Notify the Engineer at least 5 days prior to commencing demolition operations.
- C. Perform demolition in sequencing/phases as noted and as required.

PART 2 - PRODUCTS

2.1 MISCELLANEOUS METALS

- A. Steel plates, shapes, bars, and bar grating: ASTM A 36.
- B. Cold Formed Steel Tubing: ASTM A 500.
- C. Hot Rolled Steel Tubing: ASTM A 501.
- D. Steel Pipe: ASTM A 53, Schedule 40, welded.
- E. Nonshrink, Nonmetallic Grout: Premixed, factory packaged, nonstaining, noncorrosive, nongaseous grout, recommended for interior and exterior applications.
- F. Fasteners: Zinc coated, type, grade, and class as required.

2.2 MISCELLANEOUS LUMBER

- A. Framing Materials: Standard Grade, light framing size lumber of any species. Number 3 Common or Standard Grade boards complying with WCLIB or AWPB rules, or Number 3 boards complying with SPIB rules. Lumber shall be preservative treated in accordance with AWPB LP 2, and kiln dried to a moisture content of not more than 19 percent.
- B. Construction Panels: Plywood panels; APA C D PLUGGED INT, with exterior glue; thickness as indicated, or if not indicated, not less than 3/4 inches.

2.3 JOINT SEALER

- A. General: Joint sealers, joint fillers, and other related materials compatible with each other and with joint substrates under conditions of service and application.
- B. Colors: As selected by the Architect from manufacturer's standard colors.

- C. Elastomeric Joint Sealers: Provide the following types:
1. One part, nonacid curing, silicone sealant complying with ASTM C 920, Type S, Grade NS, Class 25, for uses in non traffic areas for masonry, glass, aluminum, and other substrates recommended by the sealant manufacturer.
 2. One part, mildew resistant, silicone sealant complying with ASTM C 920, Type S, Grade NS, Class 25, for uses in non traffic areas for glass, aluminum, and nonporous joint substrates; formulated with fungicide; intended for sealing interior joints with nonporous substrates; and subject to in service exposure to conditions of high humidity and temperature extremes.
 3. Available Products: Subject to compliance with requirements, products which may be incorporated in the Work include, but are not limited to, the following:
 - a. One Part, Nonacid Curing, Silicone Sealant:
 - 1) Bostik - "Chem Caulk 2000"
 - 2) Dow Corning - "Dow Corning 790"
 - 3) Pecora Corp – "864NST"
 - b. One Part, Mildew Resistant, Silicone Sealant:
 - 1) Dow Corning - "Dow Corning 786"
 - 2) GE - "SCS 1702"
 - 3) Pecora Corp. - "898"
- D. Acrylic Emulsion Sealants: One part, nonsag, mildew resistant, paintable complying with ASTM C 834 recommended for exposed applications on interior and protected exterior locations involving joint movement of not more than plus or minus 5 percent.
1. Available Products: Subject to compliance with requirements, products which may be incorporated in the Work include, but are not limited to, the following:
 - a. Bostik - "Chem Caulk 600"
 - b. Pecora Corp. - "AC 20"
 - c. Tremco – "Tremflex 834"
- E. Fire Resistant Joint Sealers: Two part, foamed in place, silicone sealant formulated for use in through penetration fire stopping around cables, conduit, pipes, and duct penetrations through fire rated walls and floors. Sealants and accessories shall have fire resistance ratings indicated, as established by testing identical assemblies in accordance with ASTM E 814, by Underwriters' Laboratories, Inc., or other testing and inspection agency acceptable to authorities having jurisdiction.

1. Available Products: Subject to compliance with requirements, products which may be incorporated in the Work include, but are not limited to, the following:
 - a. Dow Corning - "Dow Corning Fire Stop Foam"
 - b. GE - "Pensil 851"
 - c. Hilti – "CP-620 Fire Stop Foam"

2.4 ACCESS DOORS

- A. Steel Access Doors and Frames: Factory fabricated and assembled units, complete with attachment devices and fasteners ready for installation. Joints and seams shall be continuously welded steel, with welds ground smooth and flush with adjacent surfaces.
- B. Frames: 16 gage steel, with a 1 inch wide exposed perimeter flange for units installed in unit masonry, pre cast, or cast in place concrete, ceramic tile, or wood paneling.
 1. For installation in masonry, concrete, ceramic tile, or wood paneling: 1 inch wide exposed perimeter flange and adjustable metal masonry anchors.
 2. For gypsum wallboard or plaster: perforated flanges with wallboard bead.
 3. For full bed plaster applications: galvanized expanded metal lath and exposed casing bead, welded to perimeter of frame.
- C. Flush Panel Doors: 14 gage sheet steel, with concealed spring hinges or concealed continuous piano hinge set to open 175 degrees; factory applied prime paint.
 1. Fire Rated Units: Insulated flush panel doors, with continuous piano hinge and self closing mechanism.
- D. Locking Devices: Flush, screwdriver operated cam locks.
- E. Available Manufacturers: Subject to compliance with requirements, manufacturers offering products which may be incorporated in the Work include, but are not limited to, the following:
 1. Bar Co., Inc.
 2. J.L. Industries.
 3. Karp Associates, Inc.
 4. Milcor Div. Inryco, Inc.
 5. Nystrom, Inc.

PART 3 - EXECUTION

3.1 EXAMINATION

- A. Examine substrates, areas, and conditions, with Installer present, for compliance with requirements for installation tolerances and other conditions affecting installation and application of joint sealers and access panels. Do not proceed with installation until unsatisfactory conditions have been corrected.

3.2 PREPARATION FOR JOINT SEALER

- A. Surface Cleaning for Joint Sealers: Clean surfaces of joints immediately before applying joint sealers to comply with recommendations of joint sealer manufacturer.
- B. Apply joint sealer primer to substrates as recommended by joint sealer manufacturer. Protect adjacent areas from spillage and migration of primers, using masking tape. Remove tape immediately after tooling without disturbing joint seal.

3.3 ERECTION OF METAL SUPPORTS AND ANCHORAGE

- A. Cut, fit, and place miscellaneous metal fabrications accurately in location, alignment, and elevation to support and anchor electrical materials and equipment.
- B. Field Welding: Comply with AWS "Structural Welding Code."

3.4 ERECTION OF WOOD SUPPORTS AND ANCHORAGE

- A. Cut, fit, and place wood grounds, nailers, blocking, and anchorage accurately in location, alignment, and elevation to support and anchor electrical materials and equipment.
- B. Select fastener sizes that will not penetrate members where opposite side will be exposed to view or will receive finish materials. Make tight connections between members. Install fasteners without splitting wood members.
- C. Attach to substrates as required to support applied loads.
- D. Do not install wood materials in areas being utilized as air plenum or other spaces where a potential combustible hazard exists.

3.5 APPLICATION OF JOINT SEALERS

- A. General: Comply with joint sealer manufacturers' printed application instructions applicable to products and applications indicated, except where more stringent requirements apply.
 - 1. Comply with recommendations of ASTM C 962 for use of elastomeric joint sealants.
 - 2. Comply with recommendations of ASTM C 790 for use of acrylic emulsion joint sealants.

- B. Tooling: Immediately after sealant application and prior to time shinning or curing begins, tool sealants to form smooth, uniform beads; to eliminate air pockets; and to ensure contact and adhesion of sealant with sides of joint. Remove excess sealants from surfaces adjacent to joint. Do not use tooling agents that discolor sealants or adjacent surfaces or are not approved by sealant manufacturer.
- C. Installation of Fire Stopping Sealant: Install sealant, including forming, packing, and other accessory materials, to fill openings around electrical services penetrating floors and walls, to provide fire stops with fire resistance ratings indicated for floor or wall assembly in which penetration occurs. Comply with installation requirements established by testing and inspecting agency.

3.6 INSTALLATION OF ACCESS DOORS

- A. Set frames accurately in position and securely attached to supports, with face panels plumb and level in relation to adjacent finish surfaces.
- B. Adjust hardware and panels after installation for proper operation.

END OF SECTION 16050

SECTION 16060 – ELECTRICAL DEMOLITION

PART 1 - GENERAL

1.1 RELATED DOCUMENTS

- A. Drawings and general provisions of Contract, including General and Supplementary Conditions and Division 1 Specification Sections, apply to this and the other sections of Division 16.

1.1 DESCRIPTION OF WORK

- A. Demolish designated and required elements of existing electrical system.
- B. Removal of materials from site.
- C. Rework of existing electrical system for interface to new systems and equipment.

1.2 EXISTING CONDITIONS

- A. Conduct electrical demolition to avoid existing system damage scheduled to remain. Interface with adjoining building elements.
- B. The scope of electrical demolition shall include but not limited to the following:
 - 1. Electrical equipment, lighting, raceways and wiring made obsolete by this installation.
- C. Conduct operations with minimum interference to existing systems serving other buildings.

PART 2 - PRODUCTS – NOT USED

PART 3 - EXECUTION

1.1 PREPARATION

- A. Protect existing systems and components, which are not to be demolished.
- B. Protect existing items, which are not indicated to be altered.
- C. Provide and locate dumpster where directed by Agency.

1.2 EXECUTION

- A. Demolish in an orderly and careful manner.
- B. Except where noted otherwise, immediately remove demolished materials from site.
- C. Cease operations and notify Engineer immediately if adjacent systems appear to be endangered. Do not resume operations until corrective measures have been

taken.

- D. Do not burn or bury materials on site.
- E. Remove designated electrical systems and equipment as noted above and in accordance with the Contract Documents, and Electrical Drawings.
- F. Where penetrations through walls are to be closed and patched, both sides of wall shall be closed and patched
- G. Removed demolished materials from site as work progresses. Leave site in clean condition.
- H. Remove dumpster and clean and repair to original condition.

END OF SECTION 16060

SECTION 16110 – RACEWAYS

PART 1 - GENERAL

1.1 RELATED DOCUMENTS

- A. Drawings and general provisions of Contract, including General and Supplementary Conditions and Division 1 Specification Sections, apply to this Section.
- B. Requirements specified in other Division 16 Sections apply to this section.

1.2 SUMMARY

- A. This Section includes raceways for electrical wiring. Types of raceways in this section include the following:
 - 1. Rigid metal conduit.
 - 2. Intermediate metal conduit.
 - 3. Liquidtight flexible conduit.
 - 4. Flexible metal conduit.
 - 5. Electrical Metallic Tubing (EMT).
 - 6. Rigid nonmetallic conduit.
 - 7. Wireways.
- B. This section includes cabinets, boxes, and fittings for electrical installations and certain types of electrical fittings not covered in other sections. Types of products specified in this Section include:
 - 1. Outlet and device boxes.
 - 2. Pull and junction boxes.
 - 3. Cabinets.
 - 4. Hinged door enclosures.
- C. Related Sections: The following Division 16 Sections contain requirements that relate to this Section:
 - 1. "Wires and Cables" for other wiring methods.
 - 2. "Supporting Devices" for raceway supports.

1.3 DEFINITIONS

- A. Cabinets: An enclosure designed either for surface or for flush mounting and having a frame, or trim in which a door or doors may be mounted.
- B. Device Box: An outlet box designed to house a receptacle device or a wiring box designed to house a switch.
- C. Enclosure: A box, case, cabinet, or housing for electrical wiring or components.

- D. Outlet Box: A wiring enclosure where current is taken from a wiring system to supply utilization equipment.
- E. Wiring Box: An enclosure designed to provide access to wiring systems or for the mounting of indicating devices or of switches for controlling electrical circuits.

1.4 SUBMITTALS

- A. General: Submit the following in accordance with Conditions of Contract and Division 1 Specification Sections:
 - 1. Product data for Raceway systems.
 - 2. Product data for cabinets and enclosures with classification higher than NEMA 1.
 - 3. Shop drawings for boxes, enclosures and cabinets that are to be shop fabricated, (nonstock items). For shop fabricated junction and pull boxes, show accurately scaled views and spatial relationships to adjacent equipment. Show box types, dimensions, and finishes.

1.5 QUALITY ASSURANCE

- A. UL Listing and Labeling: Items provided under this section shall be listed and labeled by UL.
- B. Nationally Recognized Testing Laboratory Listing and Labeling (NRTL): Items provided under this section shall be listed and labeled by a NRTL. The term "NRTL" shall be as defined in OSHA Regulation 1910.7.
- C. National Electrical Code Compliance: Components and installation shall comply with NFPA 70 "National Electrical Code."
- D. NEMA Compliance: Comply with NEMA Standard 250, "Enclosures for Electrical Equipment (1000 Volts Maximum)."
- E. NEMA Compliance: Comply with applicable requirements of NEMA standards pertaining to raceways.
- F. Provide raceway products and components listed and labeled by UL, ETL, or CSA.

1.6 SEQUENCING AND SCHEDULING

- A. Coordinate with other Work, including metal and concrete deck installation, as necessary to interface installation of electrical raceways and components with other Work.

PART 2 - PRODUCTS

2.1 MANUFACTURERS

- A. Available Manufacturers: Subject to compliance with requirements, manufacturers offering products that may be incorporated in the Work include, but are not limited to, the following:

- B. Conduit Bodies:
 - 1. Appleton Electric Co.
 - 2. Carlon
 - 3. Killark Electric Mfg. Co.
 - 4. O Z/Gedney
 - 5. Spring City Electrical Mfg. Co.

- C. Wireways:
 - 1. Erickson Electric Equipment Co.
 - 2. GS Metals Corp.
 - 3. Hoffman Engineering Co.

- D. Cabinets:
 - 1. Erickson Electrical Equipment Co.
 - 2. Hoffman Engineering Co.
 - 3. Spring City Electrical Mfg. Co.
 - 4. Square D Co.

2.2 METAL CONDUIT AND TUBING

- A. Rigid Steel Conduit: ANSI C80.1.

- B. Intermediate Steel Conduit: UL 1242.

- C. Electrical Metallic Tubing and Fittings: ANSI C80.3

- D. Flexible Metal Conduit: UL 1, zinc coated steel.

- E. Liquid-tight Flexible Metal Conduit and Fittings: UL 360. Fittings shall be specifically approved for use with this raceway.

2.3 NONMETALLIC CONDUIT AND DUCTS

- A. Rigid Nonmetallic Conduit: NEMA TC 2 and UL 651, Schedule 40 or 80 PVC.

- B. PVC Conduit and Tube Fittings: TC 3; match to conduit or conduit/tube type and material.

- C. Conduit, Tubing and Duct Accessories: Types, sizes and materials complying with manufacturer's published product information. Match and ,atch to raceway.

2.4 CONDUIT BODIES

- A. General: Types, shapes, and sizes as required to suit individual applications and NEC requirements. Provide matching gasketed covers secured with corrosion resistant screws.
- B. Metallic Conduit and Tubing: Use metallic conduit bodies. Use bodies with threaded hubs for threaded raceways.
- C. Conduit Bodies 1 Inch and Smaller: Use bodies with compression type threaded connectors.
- D. Nonmetallic Conduit and Tubing: Use nonmetallic conduit bodies conforming to UL 514B

2.5 WIREWAYS

- A. General: Electrical wireways shall be of types, sizes, and number of channels indicated. Fittings and accessories including but not limited to couplings, offsets, elbows, expansion joints, adapters, hold-down straps, and end caps shall match and mate with wireway as required for completed system. Where features are not indicated, select to fulfill wiring requirements and comply with applicable provisions of NEC.
- B. Wireway covers to be hinged type.

2.6 CABINETS, BOXES, AND FITTINGS, GENERAL

- A. Electrical Cabinets, Boxes, and Fittings: Of indicated types, sizes, and NEMA enclosure classes. Where not indicated, provide units of types, sizes, and classes appropriate for the use and location. Provide all items complete with covers and accessories required for the intended use. Provide gaskets for units in damp or wet locations. This applies to kitchen areas.
- B. Materials and finish
 - 1. Sheet Steel: Flat rolled, code gage, galvanized steel.
 - 2. Fasteners for General Use: Corrosion resistant screws and hardware including cadmium and zinc plated items.
 - 3. Fasteners for Damp or Wet Locations: Stainless steel screws and hardware.
 - 4. Cast Metal for Boxes, Enclosures, and Covers; Copper free aluminum except as otherwise specified.
 - 5. Exterior Finish: Gray baked enamel for items exposed in finished locations except as otherwise indicated.
 - 6. Painted Interior Finish: Where indicated, white baked enamel.
 - 7. Fittings for Boxes, Cabinets, and Enclosures: Conform to UL 514B. Malleable iron or zinc plated steel for conduit hubs, bushings and box connectors.

2.7 METAL OUTLET, DEVICE, AND SMALL WIRING BOXES

- A. General: Conform to UL 514A, "Metallic Outlet Boxes, Electrical," and UL 514B, "Fittings for Conduit and Outlet Boxes." Boxes shall be of type, shape, size, and depth to suit each location and application.
- B. Steel Boxes: Conform to NEMA OS 1, "Sheet Steel Outlet Boxes, Device Boxes, Covers, and Box Supports." Boxes shall be sheet steel with stamped knockouts, threaded screw holes and accessories suitable for each location including mounting brackets and straps, cable clamps, exterior rings and fixture studs.
- C. Cast Iron Boxes: Iron alloy, waterproof, with threaded raceway entries and features and accessories suitable for each location, including mounting ears, threaded screw holes for devices and closure plugs.

2.8 PULL OR JUNCTION BOXES

- A. General: Comply with UL 50, "Electrical Cabinets and Boxes", for boxes over 100 cubic inches volume. Boxes shall have screwed or bolted on covers of material same as box and shall be of size and shape to suit application.
- B. Steel Boxes: Sheet steel with welded seams. Where necessary to provide a rigid assembly, construct with internal structural steel bracing.
- C. Hot Dipped Galvanized Steel Boxes: Sheet steel with welded seams. Where necessary to provide a rigid assembly, construct with internal structural steel bracing. Hot dip galvanized after fabrication. Cover shall be gasketed.
- D. Stainless Steel Boxes: Fabricate of stainless steel conforming to Type 302 of ASTM A 167, "Specification for Stainless and Heat Resisting Chromium Nickel Steel Plate, Sheet, and Strip." Where necessary to provide a rigid assembly, construct with internal structural stainless steel bracing. Cover shall be gasketed.
- E. Cast Iron Boxes: Molded of cast iron alloy with gasketed cover and integral threaded conduit entrances.

2.9 CABINETS

- A. Comply with UL 50, "Electrical Cabinets and Boxes."
- B. Construction: Sheet steel, NEMA 4 class except as otherwise indicated. Cabinet shall consist of a box and a front consisting of a one piece frame and a hinged door. Arrange door to close against a rabbet placed all around the inside edge of the frame, with a uniformly close fit between door and frame. Provide concealed fasteners, not over 24 inches apart, to hold fronts to cabinet boxes and provide for adjustment. Provide flush or concealed door

hinges not over 24 inches apart and not over 6 inches from top and bottom of door. For flush cabinets, make the front approximately 3/4 inch larger than the box all around. For surface mounted cabinets make front same height and width as box.

- C. Doors: Double doors for cabinets wider than 24 inches.
- D. Locks: Combination spring catch and key lock, with all locks for cabinets of the same system keyed alike. Locks may be omitted on signal, power, and lighting cabinets located within wire closets and mechanical electrical rooms. Locks shall be of a type to permit doors to latch closed without locking.

2.10 STEEL ENCLOSURES WITH HINGED DOORS

- A. Comply with UL 50, "Cabinets and Enclosures" and NEMA ICS 6,
- B. "Enclosures for Industrial Controls and Systems."
- C. Construction: Sheet steel, 16 gage, minimum, with continuous welded seams. NEMA class as indicated; arranged for surface mounting.
- D. Doors: Hinged directly to cabinet and removable, with approximately 3/4 inch flange around all edges, shaped to cover edge of box. Provide handle operated, key locking latch. Individual door width shall be no greater than 24 inches. Provide multiple doors where required.
- E. Mounting Panel: Provide painted removable internal mounting panel for component installation.
- F. Enclosure: NEMA 4 except as indicated. Where door gasketing is required, provide neoprene gasket attached with oil resistant adhesive, and held in place with steel retaining strips. For all enclosures of class higher than NEMA 1, use hubbed raceway entrances.

PART 3 - EXECUTION

3.1 RACEWAY WIRING METHOD

- A. Outdoors: Use the following wiring methods:
 - 1. Exposed / Concealed: Rigid metal conduit, Intermediate metal conduit.
 - 2. Underground: Rigid metal conduit, Rigid nonmetallic conduit.
 - 3. Connection to Vibrating Equipment: Including transformers and hydraulic, pneumatic, or electric solenoid or motor driven equipment: liquidtight flexible metal conduit. Maximum length six (6) feet.

- B. Indoors: Use the following wiring methods:
 - 1. Connection to Vibrating Equipment: Including transformers and hydraulic, pneumatic or electric solenoid or motor operated equipment: Flexible metal conduit. Maximum length six (6) feet.
 - 2. Exposed/Concealed branch circuits: EMT.
 - 3. Exposed/Concealed panelboard feeders: Intermediate metal conduit, Rigid metal conduit.
 - 4. Connection to vibrating equipment and hydraulic, pneumatic, or electric solenoid or motor driven equipment in moist or humid location or corrosive atmosphere, or where subject to water spray or dripping oil, grease, or water: Liquidtight flexible metal conduit. Maximum length six (6) feet.
 - 5. All conduits within finished areas shall be concealed.

3.2 RACEWAY INSTALLATION

- A. General: Install electrical raceways in accordance with manufacturer's written installation instructions, applicable requirements of NEC, and as follows:
- B. Conceal Conduit, unless indicated otherwise, within finished walls, ceilings, and floors. Keep raceways at least 6 inches away from parallel runs of flues and hot water pipes. Install raceways level and square and at proper elevations.
- C. Elevation of Raceway: Where possible, install horizontal raceway runs above water and sanitary piping.
- D. Complete installation of electrical raceways before starting installation of conductors within raceways.
- E. Provide supports for raceways as specified elsewhere in Division 16.
- F. Prevent foreign matter from entering raceways by using temporary closure protection.
- G. Protect stub ups from damage where conduits rise from floor slabs. Arrange so curved portion of bends is not visible above the finished slab.
- H. Make bends and offsets so the inside diameter is not effectively reduced. Unless otherwise indicated, keep the legs of a bend in the same plane and the straight legs of offsets parallel.
- I. Use raceway fittings that are of types compatible with the associated raceway and suitable for the use and location. For intermediate steel conduit, use threaded rigid steel conduit fittings except as otherwise indicated.

- J. Run concealed raceways with a minimum of bends in the shortest practical distance considering the type of building construction and obstructions except as otherwise indicated.
- K. Install exposed raceways parallel and perpendicular to nearby surfaces or structural members and follow the surface contours as much as practical.
- L. Run exposed, parallel, or banked raceways together. Make bends in parallel or banked runs from the same center line so that the bends are parallel. Factory elbows may be used in banked runs only where they can be installed parallel. This requires that there be a change in the plane of the run such as from wall to ceiling and that the raceways be of the same size. In other cases provide field bends for parallel raceways.
- M. Join raceways with fittings designed and approved for the purpose and make joints tight. Where joints cannot be made tight, use bonding jumpers to provide electrical continuity of the raceway system. Make raceway terminations tight. Where terminations are subject to vibration, use bonding bushings or wedges to assure electrical continuity. Where subject to vibration or dampness, use insulating bushings to protect conductors.
- N. Tighten set screws of threadless fittings with suitable tool.
- O. Terminations: Where raceways are terminated with locknuts and bushings, align the raceway to enter squarely and install the locknuts with dished part against the box. Where terminations cannot be made secure with one locknut, use two locknuts, one inside and one outside the box.
- P. Where terminating in threaded hubs, screw the raceway or fitting tight into the hub so the end bears against the wire protection shoulder. Where chase nipples are used, align the raceway so the coupling is square to the box, and tighten the chase nipple so no threads are exposed.
- Q. Install pull wires in empty raceways. Use no. 14 AWG zinc coated steel or monofilament plastic line having not less than 200 lb tensile strength. Leave not less than 12 inches of slack at each end of the pull wire.
- R. Install raceway sealing fittings in accordance with the manufacturer's written instructions. Locate fittings at suitable, approved, accessible locations and fill them with UL listed sealing compound. For concealed raceways, install each fitting in a flush steel box with a blank cover plate having a finish similar to that of adjacent plates or surfaces. Install raceway sealing fittings at the following points and elsewhere as indicated:
 - 1. Where conduits pass from warm locations to cold locations, such as the boundaries of conditioned spaces and mechanical spaces.
 - 2. Where required by the NEC.

- S. Stub up Connections: Extend conduits through concrete floor for connection to freestanding equipment with an adjustable top or coupling threaded inside for plugs and set flush with the finished floor. Extend conductors to equipment with rigid steel conduit; flexible metal conduit may be used 6 inches above the floor.
- T. Flexible Connections: Use short length (maximum of 6 ft.) of flexible conduit for recessed and semirecessed lighting fixtures, for equipment subject to vibration, noise transmission, or movement; and for all motors. Use liquidtight flexible conduit in wet locations. Install separate ground conductor across flexible connections. Light fixture flexible connections shall not exceed 15 ft.

3.3 CABINETS AND BOXES INSTALLATION, GENERAL

- A. Locations: Install items where indicated and where required to suit code requirements and installation conditions.
- B. Cap unused knockout holes where blanks have been removed and plug unused conduit hubs.
- C. Support and fasten items securely in accordance with Division 16 Section "Supporting Devices."
- D. Sizes shall be adequate to meet NEC volume requirements, but in no case smaller than sizes indicated.
- E. Remove sharp edges where they may come in contact with wiring or personnel.

3.4 APPLICATIONS

- A. Cabinets: Flush mounted, NEMA enclosure Type 1 except as otherwise indicated.
- B. Hinged Door Enclosures: NEMA Type 1 enclosure except as indicated.
- C. Hinged Door Enclosures Outdoors: Install drip hood, factory tailored to individual units.
- D. Outlet Boxes and Fittings: Install outlet and device boxes and associated covers and fittings of materials and NEMA types suitable for each location and in conformance with the following requirements:
 - 1. Interior Dry Locations: NEMA Type 1, sheet steel or as permitted by local code.
 - 2. Locations Exposed to Weather, Dampness, or Wet Locations: NEMA Type 3R enclosures.

- E. Pull and Junction Boxes: Install pull and junction boxes of materials and NEMA types suitable for each location except as otherwise indicated.

3.5 INSTALLATION OF OUTLET BOXES

- A. Outlets at Windows and Doors: Locate close to window trim.
- B. Column and Pilaster Locations: Locate outlet boxes for switches and receptacles on columns or pilasters so the centers of the columns are clear for future installation of partitions.
- C. Locations in Special Finish Materials: For outlet boxes for receptacles and switches mounted in desks or furniture cabinets or in glazed tile, concrete block, marble, brick, stone or wood walls, use rectangular shaped boxes with square corners and straight sides. Install such boxes without plaster rings. Saw cut all recesses for outlet boxes in exposed masonry walls.
- D. Gasketed Boxes: At the following locations use cast metal, threaded hub type boxes with gasketed weatherproof covers:
 - 1. Exterior locations.
 - 2. Where surface mounted on unfinished walls, columns or pilasters. (Cover gaskets may be omitted in dry locations).
 - 3. Where exposed to moisture laden atmosphere.
 - 4. Where indicated.
- E. Cast Iron Boxes: Iron alloy, waterproof, with threaded raceway entries and features and accessories suitable for each location, including mounting ears, threaded screw holes for devices and closure plugs.
- F. Mounting: Mount outlet boxes for switches with the long axis vertical or as indicated. Mount boxes for receptacles either vertically or horizontally but consistently either way. Three or more gang boxes shall be mounted with the long axis horizontal. Locate box covers or device plates so they will not span different types of building finishes either vertically or horizontally. Locate boxes for switches near doors on the side opposite the hinges and close to door trim, even though electrical floor plans may show them on hinge side.
- G. Ceiling Outlets: For fixtures, where wiring is concealed, use outlet boxes 4 inches square by 1 1/2 inches deep, minimum.
- H. Cover Plates for Surface Boxes: Use plates sized to box front without overlap.
- I. Protect outlet boxes to prevent entrance of plaster, and debris. Thoroughly clean foreign material from boxes before conductors are installed.

3.6 INSTALLATION OF PULL OR JUNCTION BOXES

- A. Box Selection: For boxes in main feeder conduit runs, use sizes not smaller than 8 inches square by 4 inches deep. Do not exceed 6 entering and 6 leaving raceways in a single box. Quantities of conductors (including equipment grounding conductors) in pull or junction box shall not exceed the following:

Size of Largest Conductors in Box	Maximum no. of Conductors in Box
No. 4/0 AWG	30
250 MCM	20
500 MCM	15
Over 500 MCM	10

1. Cable Supports: Install clamps, grids, or devices to which cables may be secured. Arrange cables so they may be readily identified. Support cable at least every 30 inches inside boxes.
2. Mount pull boxes in inaccessible ceilings with the covers flush with the finished ceiling.
3. Size: Provide pull and junction boxes for telephone, signal, and other systems at least 50 percent larger than would be required by or as indicated. Locate boxes strategically and provide shapes to permit easy pulling of future wires or cables of types normal for such systems.

3.7 INSTALLATION OF CABINETS AND HINGED DOOR ENCLOSURES

- A. Mount with fronts straight and plumb.
- B. Install with tops 78 inches above floor.
- C. Set cabinets in finished spaces flush with walls.

3.8 GROUNDING

- A. Electrically ground metallic cabinets, boxes, and enclosures. Where wiring to item includes a grounding conductor, provide a grounding terminal in the interior of the cabinet, box or enclosure.

3.9 RACEWAY ADJUSTING AND CLEANING

- A. Upon completion of installation of raceways, inspect interiors of raceways; clear all blockages and remove burrs, dirt, and construction debris.

3.10 CLEANING AND FINISH REPAIR

- A. Upon completion of installation, inspect components. Remove burrs, dirt, and construction debris and repair damaged finish including chips, scratches, abrasions and weld marks.

- B. Galvanized Finish: Repair damage using a zinc rich paint recommended by the tray manufacturer.

- C. Painted Finish: Repair damage using matching corrosion inhibiting touch up coating.

END OF SECTION 16110

SECTION 16120 – WIRES AND CABLES

PART 1 - GENERAL

1.1 RELATED DOCUMENTS

- A. Drawings and general provisions of Contract, including General and Supplementary Conditions and Division 1 Specification Sections, apply to this Section.
- B. Requirements of other specified Division 16 Sections apply to this section.

1.2 SUMMARY

- A. This Section includes wires, cables, and connectors for power, lighting, signal, control and related systems rated 600 volts and less.

1.3 SUBMITTALS

- A. Product Data for electrical wires, cables and connectors.

1.4 QUALITY ASSURANCE

- A. Regulatory Requirements: Comply with provisions of the following code:
 - B. NFPA 70 "National Electrical Code."
 - 1. Conform to applicable codes and regulations regarding toxicity of combustion products of insulating materials.
 - C. UL Compliance: Provide components which are listed and labeled by UL under the following standards.
 - 1. UL Std. 83 Thermoplastic-Insulated Wires and Cables.
 - 2. UL Std. 486A Wire Connectors and Soldering Lugs for Use with Copper Conductors.
 - 3. UL Std. 1569 Metal Clad Cable.
 - D. NEMA/ICEA Compliance: Provide components which comply with the following standards:
 - 1. WC-5 Thermoplastic-Insulated Wire and Cable for the Transmission and Distribution of Electrical Energy.
 - E. IEEE Compliance: Provide components which comply with the following standard.
 - 1. Std. 82 Test procedures for Impulse Voltage Tests on Insulated Conductors.

PART 2 - PRODUCTS

2.1 MANUFACTURERS

- A. Available Manufacturers: Subject to compliance with requirements, manufacturers offering products which may be incorporated in the work include, but are not limited to, the following:
 - 1. Wire and Cable:
 - a. American Insulated Wire Corp.
 - b. Republic Wire Inc.
 - c. Southwire Company.
 - 2. Connectors for Wires and Cable Conductors:
 - a. AMP
 - b. 3M Company
 - c. O-Z/Gedney Co.
 - d. Square D Company.

2.2 WIRES AND CABLES

- A. General: Provide wire and cable suitable for the temperature, conditions and location where installed.
- B. Conductors: Provide stranded conductors for power and lighting circuits no. 10 AWG and smaller. Provide stranded conductors for sizes no. 8 AWG and larger.
- C. Conductor Material: copper for all wires and cables.
- D. Conductor sizes indicated are based on copper.
- E. Insulation: Provide THHN/THWN-2 insulation for all conductors size 500MCM and larger, and no. 8 AWG and smaller. For all other sizes provide, THHN/THWN-2 or XHHW insulation as appropriate for the locations where installed.
- F. Color Coding for phase identification in accordance with Table 1 in Part 3 below.
- G. Jackets: Factory-applied nylon or PVC external jacketed wires and cables for pulls in raceways over 100-feet in length, for pulls in raceways with more than three equivalent 90 deg. bends, for pulls in conduits underground or under slabs on grade, and where indicated.
- H. Cables: Provide the following type(s) of cables in NEC approved locations and applications where indicated. Provide cable UL listed for particular application:
 - 1. Metal-Clad Cable: Type MC - limited to the following:
 - a. Lighting fixtures and outlets concealed in gypsum wallboard partitions.

2.3 CONNECTORS FOR CONDUCTORS

- A. Provide UL-listed factory-fabricated, solderless metal connectors of sizes, ampacity ratings, materials, types and classes for applications and for services indicated. Use connectors with temperature ratings equal to or greater than those of the wires upon which used.

PART 3 - EXECUTION

3.1 WIRING METHOD

- A. Use the following wiring methods as indicated:
 - 1. Wire: install all wire in raceway.
 - 2. Metal Clad Cable, Type MC: where wiring concealed in gypsum wall partitions, ceilings, for connections from raceway outlet boxes to lighting fixtures, unless otherwise noted.

3.2 INSTALLATION OF WIRES AND CABLES

- A. General: Install electrical cables, wires, and connectors in compliance with NEC.
- B. Coordinate cable installation with other Work.
- C. Pull conductors simultaneously where more than one is being installed in same raceway. Use UL listed pulling compound or lubricant, where necessary.
- D. Use pulling means including, fish tape, cable, rope, and basket weave wire/cable grips which will not damage cables or raceways. Do not use rope hitches for pulling attachment to wire or cable.
- E. Conceal all cable in finished spaces.
- F. Keep conductor splices to minimum.
- G. Install splice and tap connectors which possess equivalent or better mechanical strength and insulation rating than conductors being spliced.
- H. Use splice and tap connectors which are compatible with conductor material.
- I. Provide adequate length of conductors within electrical enclosures and train the conductors to terminal points with no excess. Bundle multiple conductors, with conductors larger than no 10 AWG cabled in individual circuits. Make terminations so there is no bare conductor at the terminal.
- J. Tighten electrical connectors and terminals, including screws and bolts, in accordance with manufacturer's published torque tightening values. Where

manufacturer's torquing requirements are not indicated, tighten connectors and terminals to comply with tightening torques specified in UL 486A and UL 486B.

3.3 FIELD QUALITY CONTROL

- A. Prior to energizing, check installed wires and cables with megohm meter to determine insulation resistance levels to assure requirements are fulfilled.
- B. Prior to energizing, test wires and cables for electrical continuity and for short-circuits.
- C. Subsequent to wire and cable hook-ups, energize circuits and demonstrate proper functioning. Correct malfunctioning units, and retest to demonstrate compliance.
- D. TABLE 1: Color Coding for Phase Identification:
 - 1. Color code secondary service, feeder, and branch circuit conductors with factory applied color as follows:

<u>208Y/120Volts</u>	<u>Phase</u>	<u>120/240Volts</u>
Black	A	Black
Red	B	Red
Blue	C	-
White	Neutral	White
Green	Ground	Green

END OF SECTION 16120

SECTION 16135 – CABINETS, BOXES AND FITTINGS

PART 1- GENERAL

1.1 RELATED DOCUMENTS

- A. Drawings and general provisions of Contract, including General and Supplementary Conditions and Division 1 Specification Sections, apply to this Section.
- B. Requirements specified in other Division 16 Sections apply to this section.

1.2 SUMMARY

- A. This section includes cabinets, boxes, and fittings for electrical installations and certain types of electrical fittings not covered in other sections. Types of products specified in this Section include:
 - 1. Outlet and device boxes.
 - 2. Pull and junction boxes.
 - 3. Cabinets.
 - 4. Hinged door enclosures.
- B. Conduit-body-type electrical enclosures and wiring fittings are specified in Division 16 Section "Raceways."

1.3 DEFINITIONS

- A. Cabinets: An enclosure designed either for surface or for flush mounting and having a frame, or trim in which a door or doors may be mounted.
- B. Device Box: An outlet box designed to house a receptacle device or a wiring box designed to house a switch.
- C. Enclosure: A box, case, cabinet, or housing for electrical wiring or components.
- D. Outlet Box: A wiring enclosure where current is taken from a wiring system to supply utilization equipment.
- E. Wiring Box: An enclosure designed to provide access to wiring systems or for the mounting of indicating devices or of switches for controlling electrical circuits.

1.4 SUBMITTALS

- A. General: Submit the following in accordance with Conditions of Contract and Division 1 Specification Sections:
 - 1. Product data for cabinets and enclosures with classification higher than NEMA 1.
 - 2. Shop drawings for boxes, enclosures and cabinets that are to be shop fabricated, (nonstock items). For shop fabricated junction and pull boxes, show accurately scaled views and spatial relationships to adjacent

equipment. Show box types, dimensions, and finishes.

1.5 QUALITY ASSURANCE

- A. UL Listing and Labeling: Items provided under this section shall be listed and labeled by UL.
- B. Nationally Recognized Testing Laboratory Listing and Labeling (NRTL): Items provided under this section shall be listed and labeled by a NRTL. The term "NRTL" shall be as defined in OSHA Regulation 1910.7.
- C. National Electrical Code Compliance: Components and installation shall comply with NFPA 70 "National Electrical Code."
- D. NEMA Compliance: Comply with NEMA Standard 250, "Enclosures for Electrical Equipment (1000 Volts Maximum)."

PART 2 - PRODUCTS

2.1 MANUFACTURERS

- A. Available Manufacturers: Subject to compliance with requirements, manufacturers offering products that may be incorporated in the Work include, but are not limited to, the following:
 - 1. Cabinets:
 - a. Electric Panelboard, Inc.
 - b. Erickson Electrical Equipment Co.
 - c. Hoffman Engineering Co.
 - d. Parker Electrical Mfg. Co.
 - e. Spring City Electrical Mfg. Co.
 - f. Square D Co.

2.2 CABINETS, BOXES, AND FITTINGS, GENERAL

- A. Electrical Cabinets, Boxes, and Fittings: Of indicated types, sizes, and NEMA enclosure classes. Where not indicated, provide units of types, sizes, and classes appropriate for the use and location. Provide all items complete with covers and accessories required for the intended use. Provide gaskets for units in damp or wet locations. This also applies to the exterior applications.

2.3 MATERIALS AND FINISHES

- A. Sheet Steel: Flat-rolled, code-gage, galvanized steel.
- B. Fasteners for General Use: Corrosion resistant screws and hardware including cadmium and zinc plated items.
- C. Fasteners for Damp or Wet Locations: Stainless steel screws and hardware.

- D. Cast Metal for Boxes, Enclosures, and Covers; Copper-free aluminum except as otherwise specified.
- E. Exterior Finish: Gray baked enamel for items exposed in finished locations except as otherwise indicated.
- F. Painted Interior Finish: Where indicated, white baked enamel.
- G. Fittings for Boxes, Cabinets, and Enclosures: Conform to UL 514B. Malleable iron or zinc plated steel for conduit hubs, bushings and box connectors.

2.4 METAL OUTLET, DEVICE, AND SMALL WIRING BOXES

- A. General: Conform to UL 514A, "Metallic Outlet Boxes, Electrical," and UL 514B, "Fittings for Conduit and Outlet Boxes." Boxes shall be of type, shape, size, and depth to suit each location and application.
- B. Steel Boxes: Conform to NEMA OS 1, "Sheet Steel Outlet Boxes, Device Boxes, Covers, and Box Supports." Boxes shall be sheet steel with stamped knockouts, threaded screw holes and accessories suitable for each location including mounting brackets and straps, cable clamps, exterior rings and fixture studs.
- C. Cast-Iron Boxes: Iron alloy, waterproof, with threaded raceway entries and features and accessories suitable for each location, including mounting ears, threaded screw holes for devices and closure plugs.

2.5 PULL OR JUNCTION BOXES

- A. General: Comply with UL 50, "Electrical Cabinets and Boxes", for boxes over 100 cubic inches volume. Boxes shall have screwed or bolted on covers of material same as box and shall be of size and shape to suit application.
- B. Steel Boxes: Sheet steel with welded seams. Where necessary to provide a rigid assembly, construct with internal structural steel bracing.
- C. Hot-Dipped Galvanized Steel Boxes: Sheet steel with welded seams. Where necessary to provide a rigid assembly, construct with internal structural steel bracing. Hot-dip galvanized after fabrication. Cover shall be gasketed.
- D. Stainless-Steel Boxes: Fabricate of stainless steel conforming to Type 302 of ASTM A 167, "Specification for Stainless and Heat Resisting Chromium-Nickel Steel Plate, Sheet, and Strip." Where necessary to provide a rigid assembly, construct with internal structural stainless steel bracing. Cover shall be gasketed.
- E. Cast-Iron Boxes: Molded of cast iron alloy with gasketed cover and integral threaded conduit entrances.

2.6 CABINETS

- A. Comply with UL 50, "Electrical Cabinets and Boxes."
- B. Construction: Sheet steel, NEMA 4 class except as otherwise indicated. Cabinet shall consist of a box and a front consisting of a one piece frame and a hinged door. Arrange door to close against a rabbet placed all around the inside edge of the frame, with a uniformly close fit between door and frame. Provide concealed fasteners, not over 24-inches apart, to hold fronts to cabinet boxes and provide for adjustment. Provide flush or concealed door hinges not over 24-inches apart and not over 6-inches from top and bottom of door. For flush cabinets, make the front approximately 3/4 inch larger than the box all around. For surface mounted cabinets make front same height and width as box.
- C. Doors: Double doors for cabinets wider than 24-inches.
- D. Locks: Combination spring catch and key lock, with all locks for cabinets of the same system keyed alike. Locks may be omitted on signal, power, and lighting cabinets located within wire closets and mechanical-electrical rooms. Locks shall be of a type to permit doors to latch closed without locking.

2.7 STEEL ENCLOSURES WITH HINGED DOORS

- A. Comply with UL 50, "Cabinets and Enclosures" and NEMA ICS 6,
- B. "Enclosures for Industrial Controls and Systems."
- C. Construction: Sheet steel, 16 gage, minimum, with continuous welded seams. NEMA class as indicated; arranged for surface mounting.
- D. Doors: Hinged directly to cabinet and removable, with approximately 3/4-inch flange around all edges, shaped to cover edge of box. Provide handle operated, key locking latch. Individual door width shall be no greater than 24-inches. Provide multiple doors where required.
- E. Mounting Panel: Provide painted removable internal mounting panel for component installation.
- F. Enclosure: NEMA 4 except as indicated. Where door gasketing is required, provide neoprene gasket attached with oil-resistant adhesive, and held in place with steel retaining strips. For all enclosures of class higher than NEMA 1, use hubbed raceway entrances.

PART 3 - EXECUTION

3.1 INSTALLATION, GENERAL

- A. Locations: Install items where indicated and where required to suit code requirements and installation conditions.

- B. Cap unused knockout holes where blanks have been removed and plug unused conduit hubs.
- C. Support and fasten items securely in accordance with Division 16 Section "Supporting Devices."
- D. Sizes shall be adequate to meet NEC volume requirements, but in no case smaller than sizes indicated.
- E. Remove sharp edges where they may come in contact with wiring or personnel.

3.2 APPLICATIONS

- A. Cabinets: Flush mounted, NEMA enclosure Type 1 except as otherwise indicated.
- B. Hinged Door Enclosures: NEMA Type 1 enclosure except as indicated.
- C. Hinged Door Enclosures Outdoors: Install drip hood, factory tailored to individual units.
- D. Outlet Boxes and Fittings: Install outlet and device boxes and associated covers and fittings of materials and NEMA types suitable for each location and in conformance with the following requirements:
 - 1. Interior Dry Locations: NEMA Type 1, sheet steel or as permitted by local code.
 - 2. Locations Exposed to Weather, Dampness, or Wet Locations: NEMA Type 3R enclosures.
- E. Pull and Junction Boxes: Install pull and junction boxes of materials and NEMA types suitable for each location except as otherwise indicated.

3.3 INSTALLATION OF OUTLET BOXES

- A. Outlets at Windows and Doors: Locate close to window trim.
- B. Column and Pilaster Locations: Locate outlet boxes for switches and receptacles on columns or pilasters so the centers of the columns are clear for future installation of partitions.
- C. Locations in Special Finish Materials: For outlet boxes for receptacles and switches mounted in desks or furniture cabinets or in glazed tile, concrete block, marble, brick, stone or wood walls, use rectangular shaped boxes with square corners and straight sides. Install such boxes without plaster rings. Saw cut all recesses for outlet boxes in exposed masonry walls.

- D. Gasketed Boxes: At the following locations use cast metal, threaded hub type boxes with gasketed weatherproof covers:
 - 1. Exterior locations.
 - 2. Where surface mounted on unfinished walls, columns or pilasters. (Cover gaskets may be omitted in dry locations).
 - 3. Where exposed to moisture laden atmosphere.
 - 4. Where indicated.
- E. Cast-Iron Boxes: Iron alloy, waterproof, with threaded raceway entries and features and accessories suitable for each location, including mounting ears, threaded screw holes for devices and closure plugs.
- F. Mounting: Mount outlet boxes for switches with the long axis vertical or as indicated. Mount boxes for receptacles either vertically or horizontally but consistently either way. Three or more gang boxes shall be mounted with the long axis horizontal. Locate box covers or device plates so they will not span different types of building finishes either vertically or horizontally. Locate boxes for switches near doors on the side opposite the hinges and close to door trim, even though electrical floor plans may show them on hinge side.
- G. Ceiling Outlets: For fixtures, where wiring is concealed, use outlet boxes 4-inches square by 1-1/2-inches deep, minimum.
- H. Cover Plates for Surface Boxes: Use plates sized to box front without overlap.
- I. Protect outlet boxes to prevent entrance of plaster, and debris. Thoroughly clean foreign material from boxes before conductors are installed.

3.4 INSTALLATION OF PULL OR JUNCTION BOXES

- A. Box Selection: For boxes in main feeder conduit runs, use sizes not smaller than 8-inches square by 4-inches deep. Do not exceed 6 entering and 6 leaving raceways in a single box. Quantities of conductors (including equipment grounding conductors) in pull or junction box shall not exceed the following:

Size of Largest Conductors in Box	Maximum no. of Conductors in Box
No. 4/0 AWG	30
250 MCM	20
500 MCM	15
Over 500 MCM	10

- 1. Cable Supports: Install clamps, grids, or devices to which cables may be secured. Arrange cables so they may be readily identified. Support cable at

- least every 30-inches inside boxes.
- 2. Mount pull boxes in inaccessible ceilings with the covers flush with the finished ceiling.
- 3. Size: Provide pull and junction boxes for telephone, signal, and other systems at least 50 percent larger than would be required by Article 370 of NEC, or as indicated. Locate boxes strategically and provide shapes to permit easy pulling of future wires or cables of types normal for such systems.

3.5 INSTALLATION OF CABINETS AND HINGED DOOR ENCLOSURES

- A. Mount with fronts straight and plumb.
- B. Install with tops 78-inches above floor.
- C. Set cabinets in finished spaces flush with walls.

3.6 GROUNDING

- A. Electrically ground metallic cabinets, boxes, and enclosures. Where wiring to item includes a grounding conductor, provide a grounding terminal in the interior of the cabinet, box or enclosure.

3.7 CLEANING AND FINISH REPAIR

- A. Upon completion of installation, inspect components. Remove burrs, dirt, and construction debris and repair damaged finish including chips, scratches, abrasions and weld marks.
- B. Galvanized Finish: Repair damage using a zinc-rich paint recommended by the tray manufacturer.
- C. Painted Finish: Repair damage using matching corrosion inhibiting touch-up coating.

END OF SECTION - 16135

SECTION 16143 – WIRING DEVICES

PART 1 - GENERAL

1.1 RELATED DOCUMENTS

- A. Drawings and general provisions of Contract, including General and Supplementary Conditions and Division 1 Specification Sections, apply to this Section.
- B. Requirements of the following Division 16 Sections apply to this section:
 - 1. Common Work Results for Electrical.

1.2 SUMMARY

- A. This Section includes the following:
 - 1. Receptacles
 - 2. Ground Fault Circuit Interrupter Receptacles
 - 3. Snap Switches
 - 4. Wall Plates
 - 5. Occupancy Sensors
- B. Related Sections: The following sections contain requirements that relate to this section:
 - 1. Division 16 Section "Enclosed Switches and Circuit Breakers" for devices other than snap switches and plug/receptacle sets used as disconnects for motors.

1.3 SUBMITTALS

- A. Product data for each type of product specified.
- B. Samples of those products indicated for sample submission in Architect's comments on product data submittal. Include color and finish samples of device plates and other items per Architect's request.

1.4 QUALITY ASSURANCE

- A. Regulatory Requirements: Comply with provisions of the following codes.
- B. NFPA 70 "National Electrical Code".
 - 1. UL and NEMA Compliance: Provide wiring devices which are listed and labeled by UL and comply with applicable UL and NEMA standards.

1.5 SEQUENCE AND SCHEDULING

- A. Schedule installation of finish plates after the surface upon which they are installed has received final finish.

PART 2 - PRODUCTS

2.1 MANUFACTURERS

- A. Available Manufacturers: Subject to specifications and 'Buy American' ARRA compliance with requirements, manufacturers offering products which may be incorporated in the work include, but are not limited to, the following:
1. Cooper Wiring Devices
 2. Hubbell Inc.
 3. Leviton
 4. Legrand (Pass and Seymour)

2.2 WIRING DEVICES:

- A. General: Provide wiring devices, in types, characteristics, grades, colors, and electrical ratings for applications indicated which are UL listed and which comply with NEMA WD 1 and other applicable UL and NEMA standards. Provide ivory color devices and wall plates except as otherwise indicated. Verify color selections with Architect.
- B. Receptacles: As scheduled in Table 1 in Part 3 below. Comply with UL 498 and NEMA WD 1.
- C. Ground-Fault Circuit Interrupter (GFCI) Receptacles: As indicated in Table 1 in Part 3 below; provide "feed-thru" type ground-fault circuit interrupter, with integral heavy-duty NEMA 5-20R duplex receptacles arranged to protect connected downstream receptacles on same circuit. Provide unit designed for installation in a 2-3/4 inch deep outlet box without adapter, grounding type, Class A, Group 1, per UL Standard 94.3.
- D. Snap Switches: quiet type AC switches as indicated in Table 2 in Part 3 below. Comply with UL 20 and NEMA WD1.
- E. Occupancy Sensors (ceiling): Multi-Technology, 360 degree self adjusting ceiling-mounted occupancy sensor. All sensors shall have ready accessible and user adjustable time delay and sensitivity controls. All sensors shall contain manual bypass. 2000 square foot coverage area. Provide appropriate power packs as required for installation.
- F. Occupancy Sensors (wall switch): multi-Technology, 180 degree self adjusting wall switch -mounted occupancy sensor. All sensors shall have ready accessible and user adjustable time delay and sensitivity controls. All sensors shall contain manual bypass.

2.3 WIRING DEVICE ACCESSORIES

- A. Wall plates: single and combination, of types, sizes, and with ganging and cutouts as indicated. Provide plates which mate and match with wiring

devices to which attached. Provide metal screws for securing plates to devices with screw heads colored to match finish of plates. Provide wall plate color to match wiring devices except as otherwise indicated. Provide plates possessing the following additional construction features:

1. Material and Finish: steel plate, galvanized, for building mechanical spaces.
2. Material and Finish: plastic, smooth, for tenant spaces, and other finished areas.

PART 3 - EXECUTION

3.1 INSTALLATION OF WIRING DEVICES AND ACCESSORIES:

- A. Install wiring devices and accessories as indicated, in accordance with manufacturer's written instructions, applicable requirements of NEC and in accordance with recognized industry practices to fulfill project requirements.
- B. Coordinate with other Work, including painting, electrical boxes and wiring installations, as necessary to interface installation of wiring devices with other Work.
- C. Install wiring devices only in electrical boxes which are clean; free from building materials, dirt, and debris.
- D. Install galvanized steel wallplates in unfinished spaces.
- E. Install wiring devices after wiring work is completed.
- F. Install wall plates after painting work is completed.
- G. Tighten connectors and terminals, including screws and bolts, in accordance with equipment manufacturer's published torque tightening values for wiring devices. Where manufacturer's torquing requirements are not indicated, tighten connectors and terminals to comply with tightening torques specified in UL Standard 486. Use properly scaled torque indicating hand tool.

3.2 PROTECTION

- A. Protect installed components from damage. Replace damaged items prior to final acceptance.

3.3 FIELD QUALITY CONTROL

- A. Testing: Prior to energizing circuits, test wiring for electrical continuity, and for short-circuits. Ensure proper polarity of connections is maintained. Subsequent to energizing, test wiring devices and demonstrate compliance with requirements, operating each operable device at least six times.

B. Test ground fault interruptor operation with both local and remote fault simulations in accordance with manufacturer recommendations.

C. TABLE 1

RECEPTACLES

DESIG- NATION (1)	CURRENT RATING AMPS	VOLTAGE RATING	SINGLE/ DUPLEX	NEMA CONFIG- URATION	UL GRADE	NOTES
-	20	125	DUPLEX	5-20R	SPECIFICATION GRADE	
GFCI	20	125	DUPLEX	5-20R	SPECIFICATION GRADE	INTEGRAL GFCI
GFCI WP	20	125	DUPLEX	5-20R	SPECIFICATION GRADE	INTEGRAL GFCI WEATHER- PROOF

NOTES

(1) Letter designations are used where symbols alone do not clearly designate on plans locations where specific receptacle types are used.

D. TABLE 2

SNAP SWITCHES

DESIG- NATION (1)	TYPICAL APPLICATION	VOLTAGE LOAD RATING (AC)	RATING	POLES	UL GRADE	NOTES
S	CONTROL LIGHTS	20A	120/277	1	HEAVY DUTY	-
S3	CONTROL - LIGHTS	20A	120/277	3-way	HEAVY DUTY	
S	DISCONN. MOTOR	1HP	120/277	1	HEAVY DUTY	(2)
STOL	DISCONN. MOTOR	2HP	208/480	3	HEAVY DUTY	(2)

NOTES

- (1) For snap switches, designation is the same as the symbol used on plans for the device. Type of switch is determined from plan context including type of device or circuit being controlled.
- (2) With overload element in switch.

END OF SECTION 16143

SECTION 16170 – ENCLOSED SWITCHES AND CIRCUIT BREAKERS

PART 1 - GENERAL

1.1 RELATED DOCUMENTS

- A. Drawings and general provisions of Contract, including General and Supplementary Conditions apply to this Section.
- B. Requirements specified in other Division 26 Sections apply to this section.

1.2 SUMMARY

- A. This Section includes circuit and motor disconnects.

1.3 SUBMITTALS

- A. Product data for each type of product specified.
- B. Maintenance data for circuit and motor disconnects, for inclusion in Operation and Maintenance Manual specified in Division 1 and Division 16 Section "Basic Electrical Requirements."

1.4 QUALITY ASSURANCE

- A. Electrical Component Standards: Provide components complying with NFPA 70 "National Electrical Code" and which are listed and labeled by UL. Comply with UL Standard 98 and NEMA Standard KS 1.

PART 2 - PRODUCTS

2.1 MANUFACTURERS

- A. Available Manufacturers: Subject to compliance with requirements, manufacturers offering products which may be incorporated in the work include, but are not limited to, the following:
 - 1. Appleton
 - 2. Crouse-Hinds Co.
 - 3. Eaton Corp.
 - 4. Square D Company.

2.2 CIRCUIT AND MOTOR DISCONNECT SWITCHES

- A. General: Provide circuit and motor disconnect switches in types, sizes, duties, features ratings, and enclosures as indicated. Provide NEMA 1 enclosure except for outdoor switches, and other indicated locations provide NEMA 3R enclosures with raintight hubs. For motor and motor starter disconnects, provide units with horsepower ratings suitable to the loads.

- B. Fusible Switches: Heavy duty switches, with fuses of classes and current ratings indicated. Where current limiting fuses are indicated, provide switches with non-interchangeable feature suitable only for current limiting type fuses.
- C. Non-fusible Disconnects: Heavy duty switches of classes and current ratings as indicated.
- D. Double-Throw Switches: Heavy duty switches of classes and current ratings as indicated.
- E. Provide weatherproof, NEMA Type 3R rated enclosures at exterior and wet/damp locations.

2.3 ACCESSORIES

- A. Electrical Interlocks: Provide number and arrangement of interlock contacts in switches as indicated.
- B. Captive Fuse Pullers: Provide built-in fuse pullers arranged to facilitate fuse removal.

PART 3 - EXECUTION

3.1 INSTALLATION OF CIRCUITS AND MOTOR DISCONNECTS

- A. General: Provide circuit and motor disconnect switches as indicated and where required by the above Code. Comply with switch manufacturers' printed installation instructions.

3.2 FIELD QUALITY CONTROL

- A. Testing: Subsequent to completion of installation of electrical disconnect switches, energize circuits and demonstrate capability and compliance with requirements. Except as otherwise indicated, do not test switches by operating them under load. However, demonstrate switch operation through six opening/closing cycles with circuit unloaded. Open each switch enclosure for inspection of interior, mechanical and electrical connections, fuse installation, and for verification of type and rating of fuses installed. Correct deficiencies then retest to demonstrate compliance. Remove and replace defective units with new units and retest.

END OF SECTION 16170

SECTION 16190 – SUPPORTING DEVICES

PART 1 GENERAL

1.1 RELATED DOCUMENTS

- A. Drawings and general provisions of Contract, including General and Supplementary Conditions and Division 1 Specification Sections, apply to this Section.
- B. Requirements specified in other Division 16 Sections apply to this section.

1.2 SUMMARY

- A. This Section includes secure support from the building structure for electrical items by means of hangers, supports, anchors, sleeves, inserts, seals, and associated fastenings.

1.3 SUBMITTALS

- A. General: Submit the following in accordance with Conditions of Contract and Division 1 Specification Sections.
- B. Product data for each type of product specified.
 - 1. Hanger and support schedule showing manufacturer's figure number, size, spacing, features, and application for each required type of hanger, support, sleeve, seal, and fastener to be used.
- C. Shop drawings indicating details of fabricated products and materials.
- D. Engineered Design consisting of details and engineering analysis for supports for the following items:
 - 1. Fastener supporting systems.

1.4 QUALITY ASSURANCE

- A. Electrical Component Standard: Components and installation shall comply with NFPA 70 "National Electrical Code."
- B. Electrical components shall be listed and labeled by UL, ETL, CSA, or other approved, nationally recognized testing and listing agency that provides third-party certification follow-up services.

PART 2 PRODUCTS

2.1 MANUFACTURERS

- A. Available Manufacturers: Subject to compliance with requirements, manufacturers offering products that may be incorporated in the Work include, but are not limited to, the following:
 - 1. Slotted Metal Angle and U-Channel Systems:
 - a. Allied Tube & Conduit
 - b. B-Line Systems, Inc.
 - c. GS Metals Corp.
 - d. Unistrut Diversified Products
 - 2. Conduit Sealing Bushings:
 - a. Bridgeport Fittings, Inc.
 - b. Cooper Industries, Inc.
 - c. O-Z/Gedney
 - d. Producto Electric Corp.
 - e. Raco, Inc.
 - f. Spring City Electrical Mfg. Co.
 - g. Thomas & Betts Corp.

2.2 COATINGS

- A. Coating: Supports, support hardware, and fasteners shall be protected with zinc coating or with treatment of equivalent corrosion resistance using approved alternative treatment, finish, or inherent material characteristic. Products for use outdoors shall be hot-dip galvanized.

2.3 MANUFACTURED SUPPORTING DEVICES

- A. Raceway Supports: Clevis hangers, riser clamps, conduit straps, threaded C-clamps with retainers, ceiling trapeze hangers, wall brackets, and spring steel clamps.
- B. Fasteners: Types, materials, and construction features as follows:
 - 1. Expansion Anchors: Carbon steel wedge or sleeve type.
 - 2. Toggle Bolts: All steel springhead type.
- C. Conduit Sealing Bushings: Factory-fabricated watertight conduit sealing bushing assemblies suitable for sealing around conduit, or tubing passing through concrete floors and walls. Construct seals with steel sleeve, malleable iron body, neoprene sealing grommets or rings, metal pressure rings, pressure clamps, and cap screws.
- D. Cable Supports for Vertical Conduit: Factory-fabricated assembly consisting of threaded body and insulating wedging plug for nonarmored electrical cables in riser conduits. Provide plugs with number and size of conductor gripping holes as required to suit individual risers. Construct body of malleable-iron casting with hot-dip galvanized finish.

- E. U-Channel Systems: 16-gage steel channels, with 9/16-inch-diameter holes, at a minimum of 8 inches on center, in top surface. Provide fittings and accessories that mate and match with U-channel and are of the same manufacture.

2.4 FABRICATED SUPPORTING DEVICES

- A. General: Shop- or field-fabricated supports or manufactured supports assembled from U-channel components.
- B. Steel Brackets: Fabricated of angles, channels, and other standard structural shapes. Connect with welds and machine bolts to form rigid supports.
- C. Pipe Sleeves: Provide pipe sleeves of one of the following:
 - 1. Sheet Metal: Fabricate from galvanized sheet metal; round tube closed with snaplock joint, welded spiral seams, or welded longitudinal joint. Fabricate sleeves from the following gage metal for sleeve diameter noted:
 - a. 3-inch and smaller: 20-gage.
 - b. 4-inch to 6-inch: 16-gage.
 - c. over 6-inch: 14-gage.
 - 2. Steel Pipe: Fabricate from Schedule 40 galvanized steel pipe.

PART 3 EXECUTION

3.1 INSTALLATION

- A. Install supporting devices to fasten electrical components securely and permanently in accordance with NEC requirements.
- B. Coordinate with the building structural system and with other electrical installation.
- C. Raceway Supports: Comply with the NEC and the following requirements:
 - 1. Conform to manufacturer's recommendations for selection and installation of supports.
 - 2. Strength of each support shall be adequate to carry present and future load multiplied by a safety factor of at least four. Where this determination results in a safety allowance of less than 200 lbs, provide additional strength until there is a minimum of 200 lbs safety allowance in the strength of each support.
 - 3. Install individual and multiple (trapeze) raceway hangers and riser clamps as necessary to support raceways. Provide U-bolts, clamps, attachments, and other hardware necessary for hanger assembly and for securing hanger rods and conduits.

4. Support parallel runs of horizontal raceways together on trapeze-type hangers.
 5. Support individual horizontal raceways by separate pipe hangers. Spring steel fasteners may be used in lieu of hangers only for 1-1/2-inch and smaller raceways serving lighting and receptacle branch circuits above suspended ceilings only. For hanger rods with spring steel fasteners, use 1/4-inch-diameter or larger threaded steel. Use spring steel fasteners that are specifically designed for supporting single conduits or tubing.
 6. Space supports for raceways in accordance with Table I of this section. Space supports for raceway types not covered by the above in accordance with NEC.
 7. Support exposed and concealed raceway within 1 foot of an unsupported box and access fittings. In horizontal runs, support at the box and access fittings may be omitted where box or access fittings are independently supported and raceway terminals are not made with chase nipples or threadless box connectors.
 8. In vertical runs, arrange support so the load produced by the weight of the raceway and the enclosed conductors is carried entirely by the conduit supports with no weight load on raceway terminals.
- D. Vertical Conductor Supports: Install simultaneously with installation of conductors.
- E. Miscellaneous Supports: Support miscellaneous electrical components as required to produce the same structural safety factors as specified for raceway supports. Install metal channel racks for mounting cabinets, panelboards, disconnects, control enclosures, pull boxes, junction boxes, transformers, and other devices.
- F. In open overhead spaces, cast boxes threaded to raceways need not be supported separately except where used for fixture support; support sheet metal boxes directly from the building structure or by bar hangers. Where bar hangers are used, attach the bar to raceways on opposite sides of the box and support the raceway with an approved type of fastener not more than 24 inches from the box.
- G. Sleeves: Install in concrete slabs and walls and all other fire-rated floors and walls for raceways and cable installations. For sleeves through fire rated-wall or floor construction, apply UL- listed firestopping sealant in gaps between sleeves and enclosed conduits and cables in accordance with requirements specified elsewhere.
- H. Conduit Seals: Install seals for conduit penetrations of slabs on grade and exterior walls below grade and where indicated. Tighten sleeve seal screws until sealing grommets have expanded to form watertight seal.

- I. Fastening: Unless otherwise indicated, fasten electrical items and their supporting hardware securely to the building structure, including but not limited to conduits, raceways, cables, cable trays, busways, cabinets, panelboards, transformers, boxes, disconnect switches, and control components in accordance with the following:
 - 1. Fasten by means of wood screws or screw-type nails on wood, toggle bolts on hollow masonry units, concrete inserts or expansion bolts on concrete or solid masonry, and machine screws, welded threaded studs, or spring-tension clamps on steel. Do not weld conduit, pipe straps, or items other than threaded studs to steel structures. In partitions of light steel construction, use sheet metal screws.
 - 2. Holes cut to depth of more than 1-1/2 inches in reinforced concrete beams or to depth of more than 3/4 inch in concrete shall not cut the main reinforcing bars. Fill holes that are not used.
 - 3. Ensure that the load applied to any fastener does not exceed 25 percent of the proof test load. Use vibration- and shock- resistant fasteners for attachments to concrete slabs.

- J. TESTS: Test pull-out resistance of one of each type, size, and anchorage material for the following fastener types:
 - 1. Expansion anchors.
 - 2. Toggle bolts.

- K. Provide all jacks, jigs, fixtures, and calibrated indicating scales required for reliable testing. Obtain the structural Engineer's approval before transmitting loads to the structure. Test to 90 percent of rated proof load for fastener. If fastening fails test, revise all similar fastener installations and retest until satisfactory results are achieved.

- L. Conduit seals at walk-in cooler& freezer location: Install seals for conduit penetrations into cooler or freezer equipment where conduit enters the respective conditional areas, and at slab locations.

3.2 TABLE I: SPACING FOR RACEWAY SUPPORTS

HORIZONTAL RUNS

<u>Raceway Size (Inches)</u> (1)	<u>Conductors</u>	<u>No. of in Run</u>	<u>IMC Location</u>	<u>RMC & EMT (1)</u>
1/2,3/4	1 or 2	Flat ceiling or wall.	5	5
1/2,3/4	1 or 2	Where it is difficult to provide supports except at intervals fixed by the building construction.	7	7
1/2,3/4	3 or more	Any location.	7	7
1/2-1	3 or more	Any location.		
1 & larger	1 or 2	Flat ceiling or wall.	6	6
1 & larger	1 or 2	Where it is difficult to provide supports except at intervals fixed by the building construction.	10	10
1 & larger	3 or more	Any location.	10	10
Any	Concealed.	10	10

VERTICAL RUNS

<u>Raceway Size (Inches)</u>	<u>No. of Conductors in Run</u>	<u>Location</u>	<u>RMC & IMC (1,2)</u>	<u>EMT (1)</u>
1/2,3/4	Exposed.	7	7
1,1-1/4	Exposed.	8	8
1-1/2				
and larger	Exposed.	10	10
Up to 2	Shaftway.	14	10
2-1/2	Shaftway.	16	10
3 & larger	Shaftway.	20	10
Any	Concealed.	10	10

NOTES:

(1) Maximum spacing of supports (feet).

(2) Maximum spacings for IMC above apply to straight runs only. Otherwise the maximums for EMT apply.

Abbreviations: EMT Electrical metallic tubing.
 IMC Intermediate metallic conduit.
 RMC Rigid metallic conduit.

END OF SECTION 16190

SECTION 16195 - ELECTRICAL IDENTIFICATION

PART 1 - GENERAL

1.1 RELATED DOCUMENTS

- A. Drawings and general provisions of Contract, including General and Supplementary Conditions and Division 1 Specification Sections, apply to this Section.
- B. Requirements specified in other Division 16 Sections apply to this section.

1.2 SUMMARY

- A. This Section includes identification of electrical materials, equipment, and installations. It includes requirements for electrical identification components including but not limited to the following:
 - 1. Identification labeling for switchboards, panelboards, devices, raceways, cables, and conductors.
 - 2. Operational instruction signs.
 - 3. Warning and caution signs.
 - 4. Equipment labels and signs.
- B. Related Sections: The following Sections contain requirements that relate to this Section:
 - 1. Division 16 Section "Wires and Cables." for requirements for color coding of conductors for phase identification.
- C. Refer to other Division 16 sections for additional specific electrical identification associated with specific items.

1.3 SUBMITTALS

- A. General: Submit the following in accordance with Conditions of Contract and Division 1 Specification Sections.
- B. Product Data for each type of product specified.
- C. Schedule of identification nomenclature to be used for identification signs and labels.
- D. Samples of each color, lettering style, and other graphic representation required for identification materials; samples of labels and signs.

1.4 QUALITY ASSURANCE

- A. Electrical Component Standard: Components and installation shall comply with NFPA 70 "National Electrical Code."

- B. ANSI Compliance: Comply with requirements of ANSI Standard A13.1, "Scheme for the Identification of Piping Systems," with regard to type and size of lettering for raceway and cable labels.

PART 2 - PRODUCTS

2.1 MANUFACTURERS

- A. Available Manufacturers: Subject to compliance with requirements, manufacturers offering products that may be incorporated in the Work include, but are not limited to, the following:
 1. American Labelmark Co.
 2. Ideal Industries, Inc.
 3. LEM Products, Inc.
 4. Markal Corp.
 5. National Band and Tag Co.
 6. Panduit Corp.
 7. Seton Name Plate Co.

2.2 ELECTRICAL IDENTIFICATION PRODUCTS

- A. Adhesive Marking Labels for Raceway and Cable: Pre-printed, flexible, self-adhesive labels with legend indicating voltage and service (Emergency, Lighting, Power, Light, Air Conditioning, Communications, Control, Fire, etc.).
- B. Label Size: as follows:
 1. Raceways 1-Inch and Smaller: 1-1/8 inches high by 4 inches long.
 2. Raceways Larger than 1-Inch: 1-1/8 inches high by 8 inches long.
- C. Color: Black legend on orange background.
- D. Colored Adhesive Marking Tape for Raceways, Wires, and Cables: Self-adhesive vinyl tape not less than 3 mils thick by 1 inch to 2 inches in width.
- E. Pretensioned Flexible Wraparound Colored Plastic Sleeves for Raceway and Cable Identification: Flexible acrylic bands sized to suit the raceway diameter and arranged to stay in place by pre-tensioned gripping action when coiled around the raceway or cable.
- F. Wire/Cable Designation Tape Markers: Vinyl or vinyl-cloth, self-adhesive, wraparound, cable/conductor markers with preprinted numbers and letter.
- G. Plasticized Card Stock Tags: Vinyl cloth with preprinted and field-printed legends to suit the application. Orange background, except as otherwise indicated, with Eyelet for fastener.

- H. Engraved, Plastic-Laminated Labels, Signs, and Instruction Plates: Engraving stock melamine plastic laminate, 1/16-inch minimum thick for signs up to 20 square inches, or 8 inches in length; 1/8-inch thick for larger sizes. Engraved legend in white letters on black face and punched for mechanical fasteners.
- I. Baked-Enamel Warning and Caution Signs for Interior Use: Preprinted aluminum signs, punched for fasteners, with colors, legend, and size appropriate to the location.
- J. Exterior Metal-Backed Butyrate Warning and Caution Signs: Weather-resistant, nonfading, preprinted cellulose acetate butyrate signs with 20-gage, galvanized steel backing, with colors, legend, and size appropriate to the location. Provide 1/4-inch grommets in corners for mounting.
- K. Fasteners for Plastic-Laminated and Metal Signs: Self-tapping stainless steel screws or number 10/32 stainless steel machine screws with nuts and flat and lock washers.
- L. Cable Ties: Fungus-inert, self-extinguishing, one-piece, self-locking nylon cable ties, 0.18-inch minimum width, 50-lb minimum tensile strength, and suitable for a temperature range from minus 50 deg F to 350 deg F. Provide ties in specified colors when used for color coding.

PART 3 - EXECUTION

3.1 INSTALLATION

- A. Lettering and Graphics: Coordinate names, abbreviations, colors, and other designations used in electrical identification work with corresponding designations specified or indicated. Install numbers, lettering, and colors as approved in submittals and as required by code.
- B. Install identification devices in accordance with manufacturer's written instructions and requirements of NEC.
- C. Sequence of Work: Where identification is to be applied to surfaces that require finish, install identification after completion of finish work.
- D. Conduit Identification:
 - 1. The following areas shall be identified:
 - a. On wall surfaces directly external to conduits run concealed within wall.
 - b. On all accessible surfaces of concrete envelope around conduits in vertical shafts, exposed at ceilings or concealed above suspended ceilings.

2. Apply identification to areas as follows:
 - a. Clean surface of dust, loose material, and oily films before painting.
 - b. Prime surfaces: For galvanized metal, use single-component acrylic vehicle coating formulated for galvanized surfaces. For concrete masonry units, use heavy-duty acrylic resin block filler. For concrete surfaces, use clear alkali-resistant alkyd binder-type sealer.
 - c. Apply one intermediate and one finish coat of orange silicone alkyd enamel.
 - d. Apply primer and finish materials in accordance with manufacturer's instructions.

- E. Identify Raceways of Certain Systems with Color Banding: Band exposed or accessible raceways of the following systems for identification. Bands shall be pretensioned, snap-around colored plastic sleeves, colored adhesive marking tape, or a combination of the two. Make each color band 2 inches wide, completely encircling conduit, and place adjacent bands of two-color markings in contact, side by side. Install bands at changes in direction, at penetrations of walls and floors, and at 40-foot maximum intervals in straight runs. Apply the following colors:
 1. Fire Alarm System: Red
 2. Fire Suppression Supervisory and Control System: Red
 3. Mechanical and Electrical Supervisory System: Green and Blue
 4. Telephone System: Green and Yellow

- F. Identify Junction, Pull, and Connection Boxes: Code-required caution sign for boxes shall be pressure-sensitive, self-adhesive label indicating system voltage in black, preprinted on orange background. Install on outside of box cover. Also label box covers with identity of contained circuits. Use pressure-sensitive plastic labels at exposed locations and similar labels or plasticized card stock tags at concealed boxes.

- G. Conductor Color Coding: Provide color coding for secondary service, feeder, and branch circuit conductors throughout the project secondary electrical system as follows:

<u>208Y/120 Volts</u>	<u>Phase</u>	<u>120/240Volts</u>
Black	A	Black
Red	B	Red
Blue	C	-
White	Neutral	White
Green	Ground	Green

- H. Use conductors with color factory-applied the entire length of the conductors except as follows:

1. The following field-applied color-coding methods may be used in lieu of factory-coded wire for sizes larger than No. 10 AWG.
 - a. Apply colored, pressure-sensitive plastic tape in half-lapped turns for a distance of 6 inches from terminal points and in boxes where splices or taps are made. Apply the last two laps of tape with no tension to prevent possible unwinding. Use 1-inch-wide tape in colors as specified. Do not obliterate cable identification markings by taping. Tape locations may be adjusted slightly to prevent such obliteration.
 - b. In lieu of pressure-sensitive tape, colored cable ties may be used for color identification. Apply three ties of specified color to each wire at each terminal or splice point starting 3 inches from the terminal and spaced 3 inches apart. Apply with a special tool or pliers, tighten for snug fit, and cut off excess length.

- I. Tag or label conductors as follows:
 1. Future Connections: Conductors indicated to be for future connection or connection under another contract with identification indicating source and circuit numbers.
 2. Multiple Circuits: Where multiple branch circuits or control wiring or signal conductors are present in the same box or enclosure (except for three-circuit, four-wire home runs), label each conductor or cable. Provide legend indicating source, voltage, circuit number, and phase for branch circuit wiring. Phase and voltage of branch circuit wiring may be indicated by means of coded color of conductor insulation. For control and signal wiring, use color coding or wire marking tape at terminations and at intermediate locations where conductors appear in wiring boxes, troughs, and control cabinets. Use consistent letter/number conductor designations throughout on wire marking tapes.
 3. Match identification markings with designations used in panelboards shop drawings, Contract Documents, and similar previously established identification schemes for the facility's electrical installations.

- J. Apply warning, caution, and instruction signs and stencils as follows:
 1. Install warning, caution, or instruction signs where required by NEC, where indicated, or where reasonably required to assure safe operation and maintenance of electrical systems and of the items to which they connect. Install engraved plastic-laminated instruction signs with approved legend where instructions or explanations are needed for system or equipment operation. Install butyrate signs with metal backing for outdoor items.

- K. Install equipment identification as follows:
 1. Apply equipment identification labels of engraved plastic-laminate on each major unit of electrical equipment in building, including central or master unit of each electrical system. This includes alarm systems,

unless unit is specified with its own self-explanatory identification. Except as otherwise indicated, provide single line of text, with 1/2-inch-high lettering on 1-1/2-inch-high label (2-inch-high where two lines are required), white lettering in black field. Text shall match terminology and numbering of the Contract Documents and shop drawings. Apply labels for each unit of the following categories of electrical equipment.

- a. Load centers, electrical cabinets, and enclosures.
 - b. Access doors and panels for concealed electrical items.
- L. Apply designation labels of engraved plastic laminate for disconnect switches, breakers, pushbuttons, pilot lights, motor control centers, and similar items for power distribution and control components above, except panelboards and alarm/signal components, where labeling is specified elsewhere. For panelboards, provide framed, typed circuit schedules with explicit description and identification of items controlled by each individual breaker.
- M. Install labels at locations indicated and at locations for best convenience of viewing without interference with operation and maintenance of equipment.

END OF SECTION 16195

SECTION 16452 – GROUNDING

PART 1 - GENERAL

1.1 SUMMARY

- A. This Section includes solid grounding of electrical systems and equipment. It includes basic requirements for grounding for protection of life, equipment, circuits, and systems. Grounding requirements specified in this Section may be supplemented in other sections of these Specifications.
- B. Related Sections: The following sections contain requirements that relate to this Section:
 - 1. Division 16 Section "Wires and Cables."

1.2 SUBMITTALS

- A. General: Submit the following in accordance with Conditions of Contract and Division 1 Specification Sections.
- B. Product data for ground rods, connectors and connection materials, and grounding fittings.
- C. Field-testing organization certificate, signed by the Contractor, certifying that the organization performing field tests complies with the requirements specified in Quality Assurance below.
- D. Report of field tests and observations certified by the testing organization.

1.3 QUALITY ASSURANCE

- A. Listing and Labeling: Provide products specified in this Section that are listed and labeled. The terms "listed" and "labeled" shall be defined as they are in the National Electrical Code, Article 100.
 - 1. Listing and Labeling Agency Qualifications: A "Nationally Recognized Testing Laboratory" (NRTL) as defined in OSHA Regulation 1910.7.
- B. Field-Testing Organization Qualifications: To qualify for acceptance, the independent testing organization must demonstrate, based on evaluation of organization-submitted criteria conforming to ASTM E 699, that it has the experience and capability to conduct satisfactorily the testing indicated.
- C. Electrical Component Standard: Components and installation shall comply with NFPA 70, "National Electrical Code" (NEC).
- D. UL Standard: Comply with UL 467, "Grounding and Bonding Equipment."

PART 2 - PRODUCTS

2.1 MANUFACTURERS

- A. Available Manufacturers: Subject to compliance with requirements, manufacturers offering products that may be incorporated in the Work include, but are not limited to, the following:
1. Anixter Bros., Inc.
 2. Bashlin Industries, Inc.
 3. Buckingham Mfg. Co.
 4. Erico Products, Inc.
 5. GB Electrical, Inc.
 6. Ideal Industries, Inc.
 7. O-Z/Gedney Co.
 8. Raco, Inc.
 9. Thomas & Betts Corp.

2.2 GROUNDING AND BONDING PRODUCTS

- A. Products: Of types indicated and of sizes and ratings to comply with NEC. Where types, sizes, ratings, and quantities indicated are in excess of NEC requirements, the more stringent requirements and the greater size, rating, and quantity indications govern.
- B. Conductor Materials: Copper.

2.3 WIRE AND CABLE CONDUCTORS

- A. General: Comply with Division 16 Section "Wires and Cables." Conform to NEC Table 8, except as otherwise indicated, for conductor properties, including stranding.
- B. Equipment Grounding Conductor: Green insulated.
- C. Grounding Electrode Conductor: Stranded cable.
- D. Bare Copper Conductors: Conform to the following:
1. Assembly of Stranded Conductors: ASTM B-8.

2.4 MISCELLANEOUS CONDUCTORS

- A. Ground Bus: Bare annealed copper bars of rectangular cross section.
- B. Braided Bonding Jumpers: Copper tape, braided No. 30 gage bare copper wire, terminated with copper ferrules.
- C. Bonding Strap Conductor/Connectors: Soft copper, 0.05 inch thick and 2 inches wide, except as indicated.

2.5 CONNECTOR PRODUCTS

- A. General: Listed and labeled as grounding connectors for the materials used.

- B. Pressure Connectors: High-conductivity-plated units.
- C. Bolted Clamps: Heavy-duty units listed for the application.
- D. Exothermic Welded Connections: Provided in kit form and selected for the specific types, sizes, and combinations of conductors and other items to be connected.
- E. Aluminum-To-Copper Connections: Bimetallic type, conforming to UL 96, "Lighting Protection Components," or UL 467.

2.6 GROUNDING ELECTRODES

- A. Ground Rods: Copper-clad steel with high-strength steel core and electrolytic-grade copper outer sheath, molten welded to core.
 - 1. Size: 3/4 inch by 10 feet.
 - 2. Size: 5/8 inch by 8 feet.
- B. Plate Electrodes: Copper plates, minimum 0.10 inch thick, size as required per N.E.C. indicated.

PART 3 - EXECUTION

3.1 APPLICATIONS

- A. Equipment Grounding Conductor Application: Comply with NEC Article 250 for sizes and quantities of equipment grounding conductors, except where larger sizes or more conductors are indicated.
 - 1. Install separate insulated equipment grounding conductors with circuit conductors for the following in addition to those locations where required by Code:
 - a. Lighting circuits.
 - b. Feeders and branch circuits.
 - c. Receptacle Circuits.
 - d. Single-phase motor or appliance circuits.
 - e. Three-phase motor or appliance branch circuits.
 - 2. Busway Circuits: Install separate insulated equipment ground conductor from the ground bus in the switchgear, switchboard, or distribution panel to the equipment ground terminal on the busway.
 - 3. Elevator Equipment Circuits: Install an insulated equipment grounding conductor to electrical devices operating at 120-V and above including hard-wired and plug-cord assemblies. Bond the conductor to each such unit and in accordance with manufacturer's requirements.

3.2 INSTALLATION

- A. General: Ground electrical systems and equipment in accordance with NEC requirements except where the Drawings or Specifications exceed NEC requirements.
- B. Braided-Type Bonding Jumpers: Install to connect ground clamps on water meter piping to bypass water meters electrically. Use elsewhere for flexible bonding and grounding connections.
- C. Route grounding conductors along the shortest and straightest paths possible without obstructing access or placing conductors where they may be subjected to strain, impact, or damage, except as indicated.
- D. Bond interior metal piping systems and metal air ducts to equipment ground conductors of pumps, fans, electric heaters, and air cleaners serving individual systems.

3.3 CONNECTIONS

- A. General: Make connections in such a manner as to minimize possibility of galvanic action or electrolysis. Select connectors, connection hardware, conductors, and connection methods so metals in direct contact will be galvanically compatible.
 - 1. Use electroplated or hot-tin-coated materials to assure high conductivity and make contact points closer in order of galvanic series.
 - 2. Make connections with clean bare metal at points of contact.
 - 3. Aluminum to steel connections shall be with stainless steel separators and mechanical clamps.
 - 4. Aluminum to galvanized steel connections shall be with tin-plated copper jumpers and mechanical clamps.
 - 5. Coat and seal connections involving dissimilar metals with inert material such as red lead paint to prevent future penetration of moisture to contact surfaces.
- B. Terminate insulated equipment grounding conductors for feeders and branch circuits with pressure-type grounding lugs. Where metallic raceways terminate at metallic housings without mechanical and electrical connection to the housing, terminate each conduit with a grounding bushing. Connect grounding bushings with a bare grounding conductor to the ground bus in the housing. Bond electrically noncontinuous conduits at both entrances and exits with grounding bushings and bare grounding conductors.
- C. Tighten grounding and bonding connectors and terminals, including screws and bolts, in accordance with manufacturer's published torque tightening values for connectors and bolts. Where manufacturer's torquing requirements

are not indicated, tighten connections to comply with torque tightening values specified in UL 486A and UL 486B.

- D. Compression-Type Connections: Use hydraulic compression tools to provide the correct circumferential pressure for compression connectors. Use tools and dies recommended by the manufacturer of the connectors. Provide embossing die code or other standard method to make a visible indication that a connector has been adequately compressed on the ground conductor.
- E. Moisture Protection: Where insulated ground conductors are connected to ground rods or ground buses, insulate the entire area of the connection and seal against moisture penetration of the insulation and cable.

3.4 FIELD QUALITY CONTROL

- A. Independent Testing Organization: Arrange and pay for the services of a qualified independent electrical testing organization to perform tests described below.
- B. Tests: Subject the completed grounding system to a megger test at each location where a maximum ground resistance level is specified, at service disconnect enclosure ground terminal, and at ground test wells. Measure ground resistance without the soil being moistened by any means other than natural precipitation or natural drainage or seepage and without chemical treatment or other artificial means of reducing natural ground resistance. Perform tests by the 2-point method in accordance with Section 9.03 of IEEE 81, "Guide for Measuring Earth Resistivity, Ground Impedance and Earth Surface Potentials of a Grounding System."
- C. Ground/resistance maximum values shall be as follows:
 - 1. Equipment rated 500 kVA and less: 5 Ohms
 - 2. Equipment rated 500 kVA to 1000 kVA: 5 Ohms
 - 3. Equipment rated over 1000 kVA: 3 Ohms
 - 4. Pad Mounted equipment: 5 ohms.
- D. Deficiencies: Where ground resistances exceed specified values, and if directed, modify the grounding system to reduce resistance values. Where measures are directed that exceed those indicated the provisions of the Contract, covering changes will apply.
- E. Report: Prepare test reports, certified by the testing organization, of the ground resistance at each test location. Include observations of weather and other phenomena that may affect test results. Describe measures taken to improve test results.

END OF SECTION 16452

SECTION 16475 – OVERCURRENT PROTECTIVE DEVICES

PART 1 - GENERAL

1.1 RELATED DOCUMENTS

- A. Drawings and general provisions of Contract, including General and Supplementary Conditions apply to this Section.
- B. Requirements specified in other Division 16 Sections apply to this section.

1.2 SUMMARY

- A. This Section includes overcurrent protective devices (OCPDs) rated 600 V and below and switching devices commonly used with them.
- B. Panelboards: Application, installation, and other related requirements for overcurrent protective device installations in distribution equipment are specified in other Division 16 sections.

PART 2 - PRODUCTS

2.1 MANUFACTURERS

- A. Available Manufacturers: Subject to compliance with requirements, manufacturers offering products that may be incorporated in the Work include, but are not limited to, the following:
 - 1. Cartridge Fuses:
 - a. Bussmann
 - b. Ferraz Shawmut
 - c. Littelfuse Inc.
 - 2. Fusible Switches:
 - a. Allen Bradley Co.
 - b. Crouse Hinds Distribution Equipment.
 - c. Eaton Corp.
 - d. General Electric Co.
 - e. Siemens Energy & Automation, Inc.
 - f. Schneider Electric (Square D)
 - 3. Molded Case Circuit Breakers:
 - a. Eaton Corp.
 - b. General Electric Co.
 - c. Siemens Energy & Automation, Inc.
 - d. Schneider Electric (Square D)

2.2 OVERCURRENT PROTECTIVE DEVICES (OCPDs), GENERAL

- A. General: Provide OCPDs in indicated types, as integral components of panelboards and also as individually enclosed and mounted single units.
- B. General: Provide OCPDs in indicated types, as integral components of panelboards, switchboards, and motor control centers; and also as individually enclosed and mounted single units.
- C. Enclosures: NEMA 250 "Enclosures for Electrical Equipment (1,000 Volts Maximum)."

2.3 CARTRIDGE FUSES

- A. General: NEMA Standard FU1, "Low Voltage Cartridge Fuses." Unless indicated otherwise, provide nonrenewable cartridge fuses of indicated types, classes, and current ratings that have voltage ratings consistent with the circuits on which used.
- B. Class J Fuses: UL 198C, "High Interrupting Capacity Fuses, Current Limiting Type."
- C. Class L Fuses: UL 198C, "High Interrupting Capacity Fuses, Current Limiting Type."
- D. Class RK1 and RK5 Dual Element Time Delay Fuses: UL 198E, "Class R Fuses."
- E. Class RK1 Fast Acting Fuses: UL 198E, "Class R Fuses."

2.4 FUSIBLE SWITCHES

- A. General: UL 98 "Enclosed and Dead Front Switches" and NEMA KS 1 "Enclosed Switches," quick make, quick break heavy duty units.
- B. Rating: Load breaking capacity in excess of the normal horsepower rating for the switch.
- C. Withstand Capability: In excess of the let through current permitted by its fuse when subject to faults up to 100,000 RMS symmetrical amperes.
- D. Operation: By means of external handle.
- E. Interlock: Prevents access to switch interior except when in "off" position.
- F. Fuse Clips: Rejection type.
- G. Padlocking Provisions: For 2 padlocks, whether open or closed.

- H. Enclosure for Independent Mounting: NEMA Type 1 enclosure except as otherwise indicated or required to suit environment where located.

2.5 MOLDED CASE CIRCUIT BREAKERS

- A. General: UL 489, "Molded Case Circuit Breakers and Circuit Breaker Enclosures," and NEMA AB 1, "Molded Case Circuit Breakers."
- B. Construction: Bolt in type, except breakers 225 ampere frame size and larger may be plug in type if held in place by positive locking device requiring mechanical release for removal.
- C. Construction: Bolt in type, except breakers in load center type panelboards and breakers 225 ampere frame size and larger may be plug in type if held in place by positive locking device requiring mechanical release for removal.
- D. Characteristics: Indicated frame size, trip rating, number of poles, and a short circuit interrupting capacity rating of 10,000 amperes symmetrical, unless a greater rating is indicated.
- E. Tripping Device: Quick make, quick break toggle mechanism with inverse time delay and instantaneous overcurrent trip protection for each pole.
- F. Enclosure for Panelboard Mounting: Suitable for panel mounting in switchboard or panelboards where indicated.
- G. Enclosure for Independent Mounting: NEMA Type 1 enclosure, except as otherwise indicated or required to suit environment where located.

PART 3 - EXECUTION

3.1 INSTALLATION

- A. Independently Mounted OCPDs: Locate as indicated and install in accordance with manufacturer's written installation instructions.
- B. OCPDs in distribution equipment shall be factory installed.

3.2 IDENTIFICATION

- A. Identify components in accordance with Division 26 Section "Electrical Identification."

3.3 CONTROL WIRING INSTALLATION

- A. Install wiring between OCPDs and control/indication devices as specified in Division 16 Section "Wires and Cables" for hard wired connections.

3.4 CONNECTIONS

- A. Check connectors, terminals, bus joints, and mountings for tightness. Tighten field connected connectors and terminals, including screws and bolts, in accordance with equipment manufacturer's published torque tightening values. Where manufacturer's torquing requirements are not indicated, tighten connectors and terminals to comply with tightening torques specified in UL 486A and UL 486B.

3.5 GROUNDING

- A. Provide equipment grounding connections for individually mounted OCPD units as indicated and as required by NEC. Tighten connectors to comply with tightening torques specified in UL Standard 486A to assure permanent and effective grounding.

3.6 FIELD QUALITY CONTROL

- A. Independent Testing Organization: Arrange and pay for the services of an independent electrical testing organization to perform tests and observations on OCPDs.
- B. Reports: Prepare written reports certified by testing organization on tests and observations. Report defective materials and workmanship and unsatisfactory test results. Include complete records of repairs and adjustments made.
- C. Labeling: Upon satisfactory completion of tests and related effort, apply a label to tested components indicating test results, date, and responsible organization and person.
- D. Schedule visual and mechanical inspections and electrical tests with at least one week's advance notification.
- E. Pretesting: Upon completing installation of the system, perform the following preparations for independent tests:
 - 1. Make insulation resistance tests of OCPD buses, components, and connecting supply, feeder, and control circuits.
 - 2. Make continuity tests of circuits.
 - 3. Provide set of Contract Documents to test personnel. Include full updating on final system configuration and parameters where they supplement or differ from those indicated in original Contract Documents.
 - 4. Provide manufacturer's instructions for installation and testing of OCPDs to test personnel.
- F. Visual and mechanical inspection: Include the following inspections and related work.
 - 1. Overcurrent Protective Device Ratings and Settings: Verify indicated ratings and settings to be appropriate for final system arrangement and parameters. Where discrepancies are found, test organization shall

- recommend final protective device ratings and settings. Use accepted revised ratings or settings to make the final system adjustments.
2. Inspect for defects and physical damage, NRTL labeling, and nameplate compliance with current single line diagram.
 3. Exercise and perform operational tests of all mechanical components and other operable devices in accordance with manufacturer's instruction manual.
 4. Check tightness of electrical connections of OCPDs with calibrated torque wrench. Refer to manufacturer's instructions for proper torque values.
 5. Clean OCPDs using manufacturer's approved methods and materials.
 6. Verify installation of proper fuse types and ratings in fusible OCPDs.
- G. Electrical Tests: Include the following items performed in accordance with manufacturer's instructions:
1. Insulation resistance test of OCPD conducting parts. Insulation resistance less than 100 megohms is not acceptable.
 2. Contact resistance test or measurement of millivolt drop across contacts of drawout circuit breakers and fused power circuit devices at rated current. Compare contact resistance or millivolt drop values of adjacent poles and of similar breakers. Deviations of more than 50 percent are not acceptable.
 3. Insulation resistance test of fused power circuit devices and insulated case and molded case circuit breakers over 600 ampere frame size at 1000 V d.c. for one minute from pole to pole and from each pole to ground with breaker closed and across open contacts of each phase. Insulation resistance less than 100 megohms is not acceptable.
 4. Use primary current injection to check performance characteristics of trip units of molded case breakers over 600 ampere frame size. Trip characteristics not falling within manufacturer's published time current characteristic tolerance bands when adjusted to approved parameters are not acceptable. Perform the following tests:
 - a. Determine minimum pickup current acceptable per manufacturer's instructions.
 - b. Determine long time delay at 300 percent pickup current.
 - c. Determine short time pickup current and corresponding delay time.
 - d. Determine ground fault current pickup and corresponding delay time.
 - e. Determine instantaneous pickup current value.
 5. Make adjustments for final settings of adjustable trip devices.
 6. Activate auxiliary protective devices such as ground fault or undervoltage relays, to verify operation of shunt trip devices.
 7. Check operation of electrically operated OCPDs in accordance with manufacturer's instructions.

- H. Retest: Correct deficiencies identified by tests and observations and provide retesting of OCPDs by testing organization. Verify by the system tests that specified requirements are met.

3.7 CLEANING

- A. Upon completion of installation, inspect OCPDs. Remove paint splatters and other spots, dirt, and debris. Touch up scratches and mars of finish to match original finish.

3.8 DEMONSTRATION

- A. Training: Arrange and pay for the services of factory authorized service representatives to demonstrate OCPDs and train Owner's maintenance personnel.
- B. Conduct a minimum of one half day of training in operation and maintenance as specified under "Instructions to Owner Employees" in the "Project Closeout" Section of these specifications. Include both classroom training and hands on equipment operation and maintenance procedures.
- C. Schedule training with at least seven days' advance notification.

3.9 COMMISSIONING

- A. Infrared Scanning: After Substantial Completion, but not more than 2 months after Final Acceptance, perform an infrared scan of OCPDs including their line and load connections, fuses, and fuse clips. Also scan OCPD contact structures where accessible to a portable scanner. Include individual OCPDs and those installed in switchboards, panelboards, and motor control centers.
- B. Follow up Infrared Scanning: Perform two additional follow up infrared scans of the same devices: one four months after Substantial Completion, and one 11 months after Substantial Completion.
- C. Instrument: Use an infrared scanning device designed to measure temperature or detect significant deviations from normal values. Provide documentation of device calibration.
- D. Record of Infrared Scanning: Prepare a certified report identifying all OCPDs checked and describing results of scanning. Include notation of deficiencies detected, remedial action taken, and rescanning observations after remedial action.

END OF SECTION 26 28 00

SECTION 16515 – EXTERIOR LIGHTING

PART 1 - GENERAL

1.1 RELATED DOCUMENTS

- A. Drawings and general provisions of Contract, including General and Supplementary Conditions apply to this Section.
- B. Requirements specified in other Division 16 Sections apply to this section.

1.2 SUMMARY

- A. This section specifies the furnishing, installation, and connection of exterior fixtures, poles, and supports. The terms “lighting fixtures”, “fixture” and “luminaire” are used interchangeably.
- B. Luminaires shall comply with Illumination Engineering Society of North America (IESNA) requirements as well as International Dark-Sky Association requirements.

1.3 DEFINITIONS

- A. Fixture: A complete lighting unit. Fixtures include lamping and parts required to distribute the light, position and protect lamping, and connect lamping to the power supply.
- B. Luminaire: Fixture.
- C. Average Life: The time after which 50 percent will have failed and 50 percent will have survived under normal conditions.

1.4 SUBMITTALS

- A. General: Submit the following in accordance with Conditions of Contract and Division 1 Specification Sections.
- B. Product data describing fixtures, lamping, drivers and ballasts. Arrange product data for fixtures in order of fixture designation. Include data on features and accessories and the following information:
 - 1. Outline drawings of fixtures indicating dimensions and principal features.
 - 2. Electrical ratings and photometric data with specified lamping and certified results of independent laboratory tests.
 - 3. Data on batteries and chargers for exterior fixtures with emergency drivers.
- C. Maintenance data for products for inclusion in Operating and Maintenance Manual specified in Division 1.

- D. Product certifications signed by manufacturers of lighting fixtures certifying that their fixtures comply with specified requirements.
- E. Shop drawings from manufactures detailing nonstandard fixtures and indicating dimensions, weights, methods of field assembly, components, features, and accessories.

1.5 QUALITY ASSURANCE

- A. Comply with NFPA 70 "National Electrical Code" for components and installation.
- B. Listing and Labeling: Provide fixtures and exit sign units that are listed and labeled for their indicated use on the Project.
 - 1. The terms "Listed" and "Labeled": As defined in the National Electrical Code, Article 100.
 - 2. Listing and Labeling Agency Qualification: A "Nationally Recognized Testing Laboratory" (NRTL) as defined in OSHA Regulation 1910.7.
- C. Manufacturers Qualifications: Firms experienced in manufacturing fixtures that are similar to those indicated for this Project and that have a record of successful in service performance.

1.6 DELIVERY, STORAGE, AND HANDLING

- A. Provide manufacturer's standard provisions for protecting fixtures during transportation, storage, and installation. Do not store outside. Store indoors in an area that is within manufacturers storage temperature range. Do not remove factory-applied wrappings until just before installation.

PART 2 - PRODUCTS

2.1 FIXTURES, GENERAL

- A. Comply with the requirements specified in the Articles below and luminaire schedule.

2.2 LUMINAIRES

- A. Luminaires shall be UL Listed for outdoor wet locations and shall utilize energy efficient LED light sources.
- B. Vandalism: Fixtures shall be vandal resistant and shall utilize a high impact acrylic or UV stabilized polycarbonate lens. Fixture hardware shall be tamper resistant.

- C. Dark Sky Friendly: Fixtures shall be full cutoff with total uplighting levels not exceeding amount allowed to be compliant with dark sky rating.

2.3 LAMPS

- A. Fixtures shall utilize LED lamp module arrays.
- B. Color temperature shall be as indicated on the luminaire schedule.

2.4 BALLASTS AND DRIVERS

- A. LED drivers shall be cold weather, field replaceable and integrated with fixture housing.
- B. Ballasts and drivers shall include a five (5) year manufacturer's warranty.

PART 3 – EXECUTION

3.1 INSTALLATION

- A. Install lighting in accordance with the NEC, as shown on the drawings, and in accordance with manufacturer's recommendations.
- B. Setting and Securing: Set units plumb, square, and level and secure according to manufacturer's printed instructions and approved shop drawings.

3.2 FIELD QUALITY CONTROL

- A. Inspect each installed fixture for damage. Replace damaged fixtures and components.
- B. Give advance notice of dates and times for field tests.
- C. Provide instruments to make and record test results.
- D. Tests: Verify normal operation of each fixture after fixtures have been installed and circuits have been energized with normal power source. Interrupt electrical energy to demonstrate proper operation of fixtures with emergency drivers. Include the following in tests of fixtures with emergency drivers.
 - 1. Duration of supply with central battery system.
 - 2. Normal transfer to battery source and retransfer to normal.
- E. Replace or repair malfunctioning fixtures and components, then retest. Repeat procedure until all units operate properly.

3.3 ADJUSTING AND CLEANING

- A. Clean fixtures upon completion of installation. Use methods and materials recommended by manufacturer.

- B. Adjust aimable fixtures to provide required light intensities.

END OF SECTION 16512

SECTION 16515 – INTERIOR LIGHTING

PART 1 - GENERAL

1.1 RELATED DOCUMENTS

- A. Drawings and general provisions of Contract, including General and Supplementary Conditions apply to this Section.
- B. Requirements specified in other Division 16 Sections apply to this section.

1.2 SUMMARY

- A. This Section includes interior luminaires.
- B. This Section also includes interior luminaires equipped with emergency driver, egress/exit lighting units and accessories.

1.3 DEFINITIONS

- A. Fixture: A complete lighting unit. Fixtures include lamping and parts required to distribute the light, position and protect lamping, and connect lamping to the power supply. Internal battery powered emergency lighting units and exit signs also include a battery and the means for controlling and recharging the battery.
- B. Luminaire: Fixture.
- C. Average Life: The time after which 50 percent will have failed and 50 percent will have survived under normal conditions.

1.4 SUBMITTALS

- A. General: Submit the following in accordance with Conditions of Contract and Division 1 Specification Sections.
- B. Product data describing fixtures, lamping, drivers and ballasts. Arrange product data for fixtures in order of fixture designation. Include data on features and accessories and the following information:
 - 1. Outline drawings of fixtures indicating dimensions and principal features.
 - 2. Electrical ratings and photometric data with specified lamping and certified results of independent laboratory tests.
 - 3. Data on batteries and chargers for emergency drivers and exit sign lighting units.
- C. Maintenance data for products for inclusion in Operating and Maintenance Manual specified in Division 1.

- D. Product certifications signed by manufacturers of lighting fixtures certifying that their fixtures comply with specified requirements.
- E. Shop drawings from manufactures detailing nonstandard fixtures and indicating dimensions, weights, methods of field assembly, components, features, and accessories.
- F. Coordination drawings for fixtures mounted on, in, or above the ceiling indicating coordination with ceiling grids and other equipment installed in the same space.
- G. Samples for verification purposes of specific individual fixtures.
- H. Samples for use in full size mockup of specific individual fixtures.

1.5 QUALITY ASSURANCE

- A. Comply with NFPA 70 "National Electrical Code" for components and installation.
- B. Listing and Labeling: Provide fixtures and exit sign units that are listed and labeled for their indicated use on the Project.
 - 1. The terms "Listed" and "Labeled": As defined in the National Electrical Code, Article 100.
 - 2. Listing and Labeling Agency Qualification: A "Nationally Recognized Testing Laboratory" (NRTL) as defined in OSHA Regulation 1910.7.
- C. Manufacturers Qualifications: Firms experienced in manufacturing fixtures that are similar to those indicated for this Project and that have a record of successful in service performance.
- D. Coordination of Fixtures With Ceiling: Coordinate fixtures mounting hardware and trim with the ceiling system.

1.6 EXTRA MATERIALS

- A. Furnish extra materials matching products installed, as described below, packaged with protective covering for storage, and identified with labels describing contents. Deliver extra materials to the Owner.
 - 1. Lamps: 10 lamps for each 100 of each type and rating installed. Furnish at least 1 of each type.
 - 2. Plastic Diffusers and Lenses: 1 for each 100 of each type and rating installed. Furnish at least 1 of each type.

PART 2 - PRODUCTS

2.1 FIXTURES, GENERAL

- A. Comply with the requirements specified in the Articles below and lighting fixture schedule.

2.2 FIXTURE COMPONENTS, GENERAL

- A. Metal Parts: Free from burrs and sharp corners and edges.
- B. Sheet Metal Components: Steel, except as indicated. Components are formed and supported to prevent warping and sagging.
- C. Doors, Frames, and Other Internal Access: Smooth operating and free from light leakage under operating conditions. Arrange to permit relamping without use of tools. Arrange doors, frames, lenses, diffusers, and other pieces to prevent accidental falling during relamping and when secured in the operating position.
- D. Reflecting Surfaces: Minimum reflectances as follows, except as otherwise indicated:
 - 1. White Surfaces: 85 percent.
 - 2. Specular Surfaces: 83 percent.
 - 3. Diffusing Specular Surfaces: 75 percent.
 - 4. Laminated Silver Metallized Film: 90 percent.
- E. Lenses, Diffusers, Covers, and Globes: 100 percent virgin acrylic plastic or water white, annealed crystal glass except as indicated.
 - 1. Plastic: Highly resistance to yellowing and other changes due to aging, exposure to heat and UV radiation.
 - 2. Lens Thickness: 0.125 inches, minimum.

2.3 LED LUMINAIRES

- A. General: Except as otherwise indicated, provide LED luminaires, of types and sizes indicated on luminaire schedules.
- B. Material and specifications for each luminaire are as follows:
 - 1. Each luminaire shall consist of an assembly that utilizes LEDs as the light source, housing, LED array, and electronic driver. LED luminaires designated for emergency lighting shall also contain and emergency driver.
 - 2. Each luminaire shall be rated for a minimum operational life of 50,000 hours.
 - 3. The LED module arrays shall be constructed such that a catastrophic loss or the failure of one LED will not result in the loss of the entire luminaire.

4. Luminaire shall be constructed such that LED module arrays can be replaced or repaired without replacement of the entire luminaire.
5. Each luminaire shall be UL 1598 and UL 8750 listed.
6. Refer to luminaire schedules for lumen output, CRI, color temperature and emergency driver requirements of each luminaire type.

2.4 EXIT SIGNS

- A. Conform to UL 924, "Emergency Lighting and Power Equipment," and the following:
 1. Sign Colors: Conform to local code.
 2. Minimum Height of Letters: Conform to local code.
 3. Arrows: Include as indicated.
 4. Lamps: Light Emitting Diodes (LED), 10 year rated lamp life.
 5. Battery: Sealed, maintenance-free.
 6. Charger: Fully automatic, solid-state type with sealed transfer relay.
 7. Operation: Relay automatically energizes lamp from battery when circuit voltage drops to 80 percent of nominal voltage or below. When normal voltage is restored, relay disconnects lamps from battery, and battery is automatically recharged and floated on charger.
 8. Test Switch: Push to test button type integral to unit.
 9. LED Indicator Light: To indicate normal power on. Normal glow shall indicate trickle charge and a bright glow shall indicate charging at end of discharge cycle.

2.5 EMERGENCY LIGHTING UNITS, DECORATIVE

- A. General: The following features apply to decorative emergency light sets:
 1. Self contained emergency lighting units with style, shape, and trim as directed by owner.
 2. Battery: Sealed, maintenance free, lead acid type with 10 year nominal life.
 3. Charger: Minimum two rate, fully automatic, solid state type, with sealed transfer relay.
 4. Operation: Relay turns lamp on automatically when supply circuit voltage drops to 80 percent of nominal or below. Lamp operates for duration of outage, up to 1.5 hours. Lamp automatically disconnected from battery of voltage approaches deep discharge level. When normal voltage is restored, battery is automatically recharged within 16 hours and then floated on trickle charge.
 5. Control panel contains low voltage disconnect switch, LED indicator light, test switch, and concealed terminals for remote lamp head connection.
- B. Cylinder Style: Lamp, battery, charger, and relay mounted in cylindrical housing. Unit shall have the following features:
 1. Cylinder shall be mounted on metal base with locking swivel joint providing 180 deg, 2 way lamp aiming.

2. Shallow profile base shall form connection box and house control panel. Mounts on wall or ceiling.
- C. Recessed Lay in Ceiling Type with Lamp Heads and the following features:
1. Fixtures shall be suitable for recessed lay in installation in 2 by 2 and 2 by 4 exposed grid ceilings without additional supports. Maximum recessing depth shall be 5 1/2 inches.
 2. Lamp head mounting panel shall be flush with finished ceiling, 18 gage steel, minimum; mounts for control panel.
 3. Two lamp heads shall be mounted on base, with 180 deg, 2 way, locking swivel joints for aiming. Frosted acrylic lenses and lamp types shall be as directed by Owner.
 4. Finish: Matte white for exposed parts, or as directed by Owner.
- D. Surface Mounted Type with Lamp Heads: Surface wall mounted, with two lamp heads, and the following features:
1. Integral lamp heads mounted on housing with 180 deg, 2 way locking swivel joints for aiming. Lamp types and lenses as directed by Owner.
 2. Finish: Exposed parts shall be matte white, or as directed by Owner.
- E. Recessed or Semi-recessed Type with Lens: Wall or ceiling mounted with the following features:
1. Lamps and reflectors as directed by Owner.
 2. Finish: Matte white for exposed parts, or as directed by Owner.
 3. Trim at wall or ceiling conceals fixture opening.
 4. Lens: 0.125 inch thick prismatic acrylic.
- F. Surface Mounted Type with Lens: Wall or ceiling mounted unit with the following features:
1. Lamps and reflectors as directed by Owner.
 2. Finish: Matte white for exposed parts or as directed by Owner.
 3. Lens: 0.125 inch thick prismatic acrylic.

2.6 EMERGENCY LIGHTING UNIT, GENERAL PURPOSE

- A. Self contained, surface wall mounted, with two lamp heads and provisions for a third lamp head, and having the following features:
1. Housing: 20 gage steel or high impact thermoplastic, conforming to UL 94 V O.
 2. LED indicator light and test switch shall be on front panel, with concealed terminals for remote lamp heads.
 3. Integral lamp heads shall be mounted on housing with 180 deg, 2 way, locking swivel joints for aiming.
 4. Battery: Sealed, maintenance free, lead acid type, with 10 year normal life.

5. Charger: Minimum 2 rate, fully automatic, solid state type, with sealed transfer relay and fused output circuits.
6. Finish: Manufacturer's standard for exposed parts, baked enamel on steel.
7. Operation: Relay turns lamps on automatically when supply circuit voltage drops to 80 percent of nominal or below. Lamps operate for duration of outage, up to 1.5 hours. Lamps automatically disconnect from battery when voltage approaches deep discharge value. When normal voltage is restored, battery is automatically recharged.

2.7 EMERGENCY POWER SUPPLY

- A. Internal Type: For designated fixture typess, provided under Division 26 Section "Lighting," provide internal self contained, modular, battery inverter unit, factory mounted within the fixture body.
 1. Arrange unit with test switch and LED indicator light, visible and accessible without opening fixture or entering ceiling space.
 2. Battery: Sealed, maintenance free, nickel cadmium type, with normal 10 year life, minimum.
 3. Charger: Fully automatic, solid state, constant current type.
 4. Operation: Relay turns two lamps on automatically when supply circuit voltage drops to 80 percent of nominal or below. Lamps operate for duration of outage, up to 1.5 hours. When normal voltage is restored, battery is automatically recharged.

- B. External Type: For designated fixture types, provided under Division 26 Section "Lighting," provide external self contained, modular, battery inverter unit.
 1. Arrange unit with test switch and LED indicator light, visible and accessible without entering ceiling space.
 2. Battery: Sealed, maintenance free, nickel cadmium type, with normal 10 year life, minimum.
 3. Charger: Fully automatic, solid state, constant current type.
 4. Operation: Relay turns two lamps of associate fixture on automatically when supply circuit voltage drops to 80 percent of nominal or below. Lamps operate for duration of outage, up to 1.5 hours. When normal voltage is restored, battery is automatically recharged.

2.8 FINISH

- A. Steel Parts: Manufacturer's standard finish applied over corrosion resistant primer, free of streaks, runs, holidays, stains, blisters, and defects. Remove fixtures showing evidence of corrosion during project warranty period and replace with new fixtures.

- B. Other Parts: Manufacturer's standard finish.

2.9 SUSPENDED FIXTURE SUPPORT COMPONENTS

- A. Suspended fixtures as indicated in manufacturers installation instructions. See fixture schedule and installation requirements listed below for further requirements.

PART 3 – EXECUTION

3.1 INSTALLATION

- A. Setting and Securing: Set units plumb, square, and level with ceiling and walls, and secure according to manufacturer's printed instructions and approved shop drawings.
- B. Support For Recessed and Semi-recessed Fixtures: Installed units are not to be supported from suspended ceiling support system. Install ceiling system support rods or wires at a minimum of four rods or wires per fixture located not more than 6 inches from fixture corners.
 1. Fixtures Smaller Than Ceiling Grid: Install a minimum of four rods or wires for each fixture and locate at corner of the ceiling grid where the fixture is located. Do not support fixtures by ceiling acoustical panels.
 2. Fixtures of Sizes Less Than Ceiling Grid: Center in the acoustical panel. Support fixtures independently with at least two 3/4 inch metal channels spanning and secured to the ceiling tees.
 3. Install support clips for recessed fixtures, securely fastened to ceiling grid members, at or near each fixture corners.
- C. Support for Suspended Fixtures: Brace pendants and rods that are 4 feet long or longer to limit swinging. Support stem mounted single unit suspended fluorescent fixtures with twin stem hangers. For continuous rows, use tubing or stem for wiring at one point and tubing or rod for suspension for each unit length of chassis, including one at each end.
- D. Lamping: Lamp units according to manufacturer's instructions.

3.2 FIELD QUALITY CONTROL

- A. Inspect each installed fixture for damage. Replace damaged fixtures and components.
- B. Give advance notice of dates and times for field tests.
- C. Provide instruments to make and record test results.
- D. Tests: Verify normal operation of each fixture after fixtures have been installed and circuits have been energized with normal power source. Interrupt electrical energy to demonstrate proper operation of emergency

lighting installation. Include the following in tests of emergency lighting equipment.

1. Duration of supply with central battery system.
 2. Normal transfer to battery source and retransfer to normal.
- E. Replace or repair malfunctioning fixtures and components, then retest. Repeat procedure until all units operate properly.

3.3 ADJUSTING AND CLEANING

- A. Clean fixtures upon completion of installation. Use methods and materials recommended by manufacturer.
- B. Adjust aimable fixtures to provide required light intensities.

END OF SECTION 16515